

<b>BRONZE AND BRASS BALL VALVES</b>	
<b>INDEX</b>	
BA-100/100S	BV-1
BA-100/100S P2	BV-2
BA-100ELD/ BA100SELD	BV-3
BA-100H/BA-150H	BV-4
BA-100SH/BA150SH	BV-5
BA-100H/BA100SH P1	BV-6
BA-100M	BV-7
BA-100-TS	BV-8
BA-150/150S	BV-9
BA-200	BV-10
BA-250	BV-11
BA-300/300S	BV-12
BA-300/300S P2	BV-13
BA-300SB/300SBS	BV-14
BA-350/350S	BV-15
BA-350TE/350STE	BV-16
BA-350TE-G/350STE-G	BV-17
BA-400/400S	BV-18
BA-400/400S P2	BV-19
BA-400S3	BV-20
BA-450/450S	BV-21
BA-475B	BV-22
BA-485B	BV-23
BA-500/500S	BV-24
BA-480B	BV-25
BA-480S	BV-26
BA-480BH	BV-27
BA-480SH	BV-28
BA-481B	BV-29
BA-481S	BV-30
BA-490B	BV-31
BA-490S	BV-32
BA-491B	BV-33
BA-491S	BV-34
Insulator Handle/MS (TIH)	BV-35 - 36
Options BA-100/150/300/350/400/450	BV-37
Options BA-200/250/475B/485B/480B/490B	BV-38

Rev 01/17

The information presented on this sheet is correct at the time of publication. Milwaukee Valve reserves the right to change design, and/or material specifications without notice. For the Installation, Operation and Maintenance Manual (IOM) see the Technical/Service Information section on our website. For the most current information access [www.milwaukeevalve.com](http://www.milwaukeevalve.com)



# BA-100/100S\* 1/4"-3"

**Bronze Ball Valve**  
**Two Piece**  
**Standard Port (1" - 3") Full Port (1/4" - 3/4")**  
**600 WOG/150 SWP (1)**  
**Threaded Ends**  
**Blow-Out Proof Stem**  
**MSS SP-110**

\*Not intended for use in potable water.

## MATERIALS LIST

ITEM	PART	MATERIALS	ASTM SPEC.
1	Body	Cast Bronze	B584
2	Tailpiece	Brass	B283
		Cast Bronze (1 1/4" & up)	B584
3	Ball	Brass w/Hard Chrome Plating	B16
		316 Stainless Steel (2)	A276
4	Seat	RPTFE, 15% Glass Filled	
5	Stem	Brass	B16
		316 Stainless Steel (2)	A276
6	Thrust Washer	RPTFE, 25% Glass Filled	
7	Packing	PTFE	
8	Packing Nut	Brass	B16
9	Handle	Steel w/Zinc Plating	Commercial
10	Hand Grip	Vinyl	
11	Handle Nut	Steel w/Zinc Plating	Commercial

- (1) Milwaukee Valve Company recommends the use of Stainless steel ball and stem for steam applications. Please consult factory for more information.  
 (2) Stem is stainless for BA-100S and 2-1/2"-3" BA-100

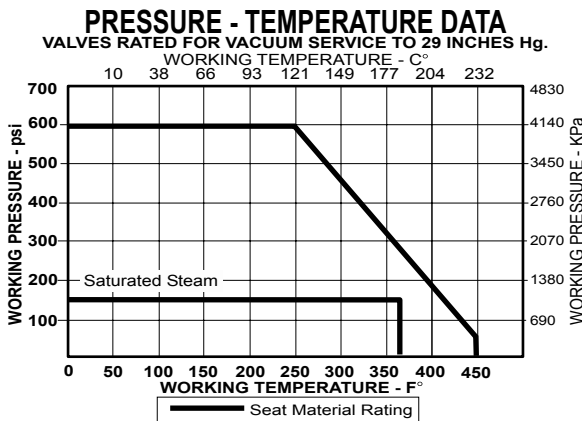
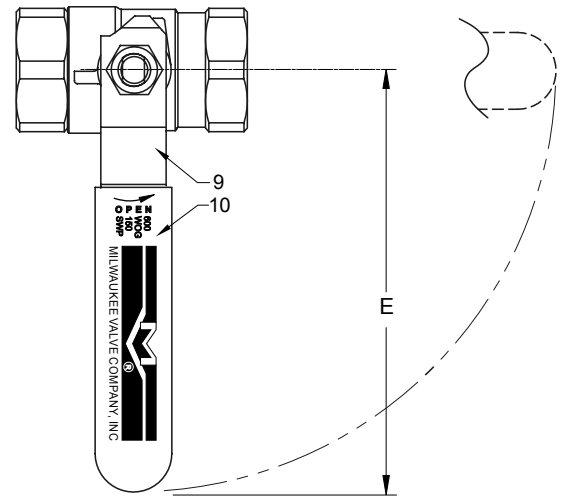
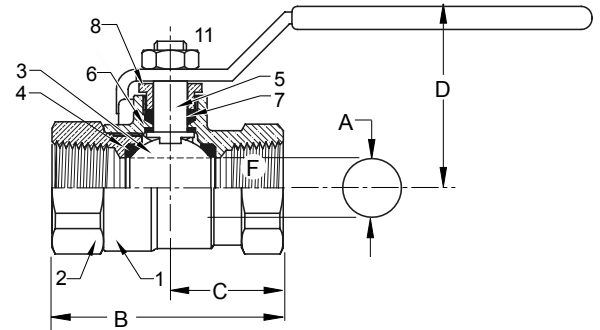

## DIMENSIONS

	UNITS	1/4" DN6	3/8" DN10	1/2" DN15	3/4" DN20	1" DN25	1-1/4" DN32	1-1/2" DN40	2" DN50	2-1/2" DN65	3" DN80
A (DIA)	INCHES	0.38	0.38	0.50	0.76	0.88	1.06	1.31	1.56	2.00	2.31
	mm	10	10	13	19	22	27	33	40	51	59
B	INCHES	1.86	1.86	2.19	2.64	3.17	3.50	3.96	4.30	5.56	6.20
	mm	46	46	54	65	78	86	97	105	136	152
C	INCHES	1.00	1.00	1.10	1.30	1.58	1.74	1.97	2.15	2.79	3.10
	mm	25	25	27	32	39	43	48	53	68	76
D	INCHES	1.78	1.81	1.91	2.08	2.25	2.66	2.84	3.00	3.47	3.90
	mm	44	44	47	51	55	65	70	74	85	96
E	INCHES	3.81	3.81	3.81	4.56	4.56	6.31	6.31	7.19	7.19	7.19
	mm	93	93	93	112	112	155	155	176	176	176
F	THREAD SIZE	1/4" NPT	3/8" NPT	1/2" NPT	3/4" NPT	1" NPT	1-1/4" NPT	1-1/2" NPT	2" NPT	2-1/2" NPT	3" NPT
Cv		7	7	13	30	38	61	87	121	228	305

Note: DN (Diameter Nominal) = Metric equivalent size.

The information presented on this sheet is correct at the time of publication. Milwaukee Valve reserves the right to change design, and/or material specifications without notice. For the Installation, Operation and Maintenance Manual (IOM) see the Technical/Service Information section on our website. For the most current information access [www.milwaukeevalve.com](http://www.milwaukeevalve.com)



# BA-100/100S\* P2 1/2"-2"

**Bronze Ball Valve**  
**Two Piece**  
 Standard Port (1" - 2") Full Port (1/2" - 3/4")  
 250 psig @ 250°F†  
 Press x Press Ends  
 Press x Threaded Ends Available (Consult Factory)  
 Blow-Out Proof Stem  
 Conforms to MSS SP-110



\*Not intended for use in potable water.

## MATERIAL LIST

ITEM	PART	MATERIAL	ASTM SPEC
1	Body	Cast Bronze	B584
2	Tailpiece	Brass	B283
		Cast Bronze (1 1/4" & up)	B584
3	Ball	Brass w/Hard Chrome Plating	B283
		316 Stainless Steel (1)	A276
4	Seat	RPTFE, 15% Glass Filled	
5	Stem	Brass	B16
		316 Stainless Steel (2)	A276
6	Thrust Washer	RPTFE, 25% Glass Filled	
7	Packing	PTFE	
8	Packing Nut	Brass	B16
9	Handle	Steel w/Zinc Plating	Commercial
10	Hand Grip	Vinyl	
11	Handle Nut	Steel w/Zinc Plating	Commercial
12	Press Adapters	Brass Fitting w/EPDM O-Ring	B283

(1) BA-100S P2

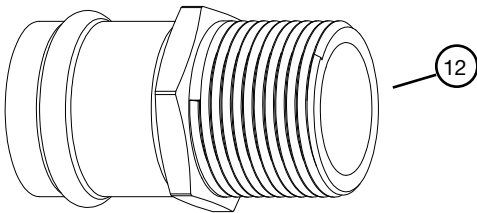
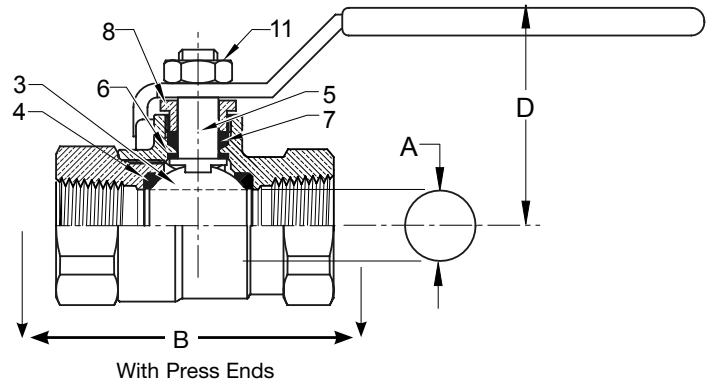

Press End Adapter (4151 Series)

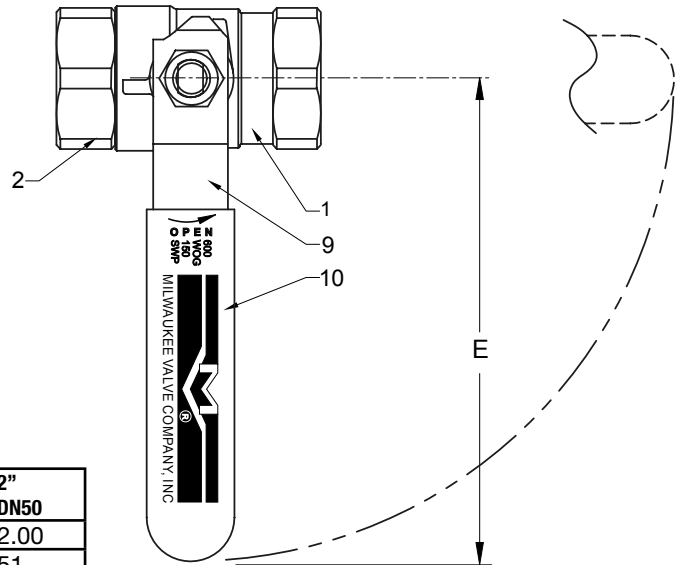

## DIMENSIONS

	UNITS	1/2" DN15	3/4" DN20	1" DN25	1-1/4" DN32	1-1/2" DN40	2" DN50
	A (DIA)	INCHES	0.50	0.76	1.06	1.31	1.56
	mm	13	19	27	33	40	51
STD INSERTION DEPTH	INCHES	0.87	0.98	0.98	1.02	1.42	1.58
	mm	22	25	25	26	36	40
B	INCHES	5.19	6.22	7.17	7.57	8.44	10.30
	mm	132	158	182	192	214	262
D	INCHES	1.91	2.32	2.68	2.82	3.00	3.36
	mm	47	59	68	72	76	85
E	INCHES	3.82	4.55	6.33	6.33	6.33	7.19
	mm	94	116	161	161	161	183

+Non-Shock



The information presented on this sheet is correct at the time of publication. Milwaukee Valve reserves the right to change design, and/or material specifications without notice. For the Installation, Operation and Maintenance Manual (IOM) see the Technical/Service Information section on our website. For the most current information access [www.milwaukeevalve.com](http://www.milwaukeevalve.com)



# BA-100ELD/BA-100SELD\*

## 1/4"-2"

**Bronze Ball Valve**  
**Two Piece**  
**Standard Port (1" - 2") Full Port (1/4" - 3/4")**  
**Safety Exhaust**  
**Locking Handle**  
**Blow-Out Proof Stem**  
**MSS SP-110**

\*Not intended for use in potable water.

### MATERIALS LIST

ITEM	PART	MATERIALS	ASTM SPEC.
1	Body	Cast Bronze	B584
2	Tailpiece	Brass	B283
		Cast Bronze (1 1/4" & up)	B584
3	Ball	Brass w/Hard Chrome Plating	B16
		316 Stainless Steel (1)	A276
4	Seat	RPTFE, 15% Glass Filled	
5	Stem	Brass	B16
		316 Stainless Steel (2)	A276
6	Thrust Washer	RPTFE, 25% Glass Filled	
7	Packing	PTFE	
8	Packing Nut	Brass	B16
9	Handle	Steel w/Zinc Plating	Commercial
10	Hand Grip	Vinyl	
11	Handle Nut	Steel w/Zinc Plating	Commercial

(1) Ball & Stem are stainless for BA-100SELD.

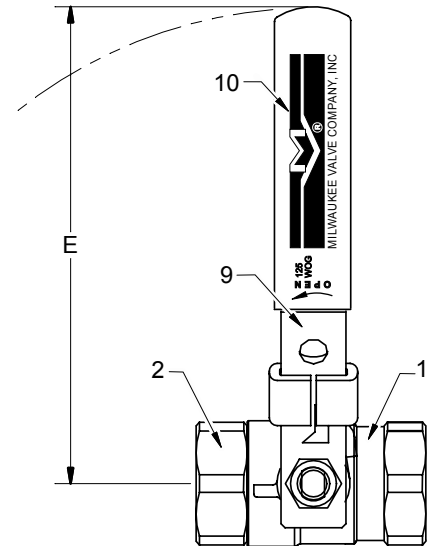

### PRESSURE - TEMPERATURE DATA

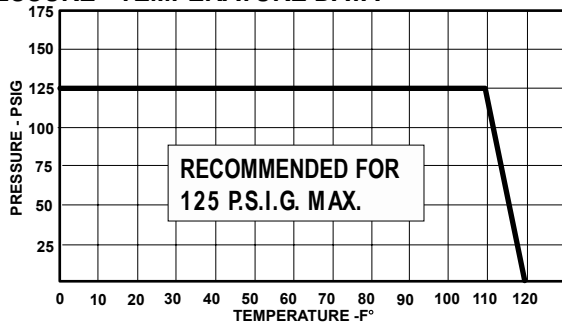

Note: Handle is shown in the open position. Ball is shown closed to illustrate vent feature.

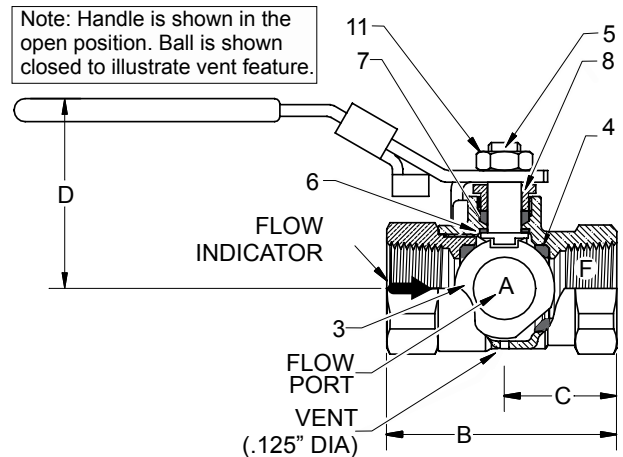

### DIMENSIONS

	UNITS	1/4" DN10	3/8" DN10	1/2" DN15	3/4" DN20	1" DN25	1-1/4" DN32	1-1/2" DN40	2" DN50
A (DIA)	INCHES	0.38	0.38	0.5	0.76	0.88	1.06	1.31	1.56
	mm	10	10	13	19	22	27	33	40
B	INCHES	1.86	1.86	2.19	2.65	3.17	3.50	3.96	4.30
	mm	47	47	55	67	80	89	101	109
C	INCHES	1	1	1.10	1.30	1.58	1.74	1.97	2.15
	mm	25	25	27	33	40	44	50	55
D	INCHES	1.81	1.81	1.91	2.08	2.25	2.66	2.84	3.00
	mm	46	46	48	53	57	67	72	76
E	INCHES	3.82	3.82	3.82	4.84	4.84	6.35	6.35	7.20
	mm	97	97	97	123	123	161	161	183
F	THREAD SIZE	1/4" NPT	3/8" NPT	1/2" NPT	3/4" NPT	1" NPT	1-1/4" NPT	1-1/2" NPT	2" NPT
Cv		7	7	12	30	38	61	87	121

Note: DN (Diameter Nominal) = Metric equivalent size.

The information presented on this sheet is correct at the time of publication. Milwaukee Valve reserves the right to change design, and/or material specifications without notice. For the Installation, Operation and Maintenance Manual (IOM) see the Technical/Service Information section on our website. For the most current information access [www.milwaukeevalve.com](http://www.milwaukeevalve.com)



# BA-100H/150H\* 1/2"-3/4"

**Bronze Ball Valve  
Two Piece  
Full Port  
Threaded x 3/4" Hose End (BA100H)  
Solder x 3/4" Hose End (BA150H)  
Dust Cap and Chain  
Blow-Out Proof Stem  
MSS SP-110**

**\*Not intended for use in potable water.**

## MATERIALS LIST

ITEM	PART	MATERIALS	ASTM SPEC.
1	Body	Bronze	B584
2	Tailpiece	Brass	B16
3	Ball	Brass w/Hard Chrome Plating	B16
4	Seat	RPTFE, 15% Glass Filled	
5	Stem	Brass	B16
6	Thrust Washer	RPTFE, 25% Glass Filled	
7	Packing	PTFE	
8	Packing Nut	Brass	B16
9	Handle	Steel w/Zinc Plating	Commercial
10	Hand Grip	Vinyl	
11	Handle Nut	Steel w/Zinc Plating	Commercial
12	Dust Cap	Polypropylene	
13	Gasket	EPDM	
14	Chain	Brass Bead	

NOTE: Pressure / Temperature ratings shown are for valve only.  
Hose side pressure and temperature limit is based on connected hose and is the users responsibility.

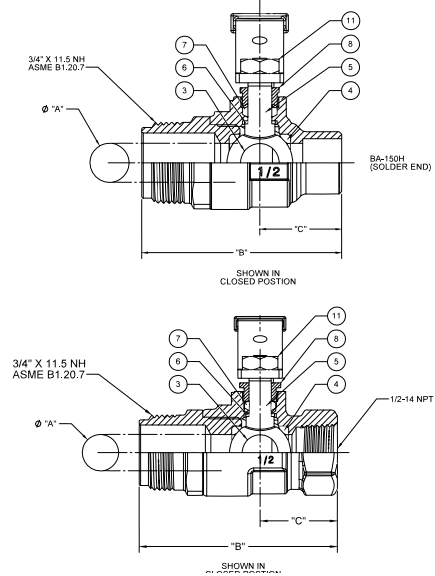

**Do not pressurize cap.  
Pressure not to exceed 40 psi.**

## DIMENSIONS

	UNITS	1/2"	3/4"
		DN15	DN20
ØA	INCHES	0.50	0.76
	mm	13	19
B (BA-100)	INCHES	2.70	2.90
	mm	69	74
B' (BA-150)	INCHES	2.55	3.05
	mm	65	78
C (BA-100)	INCHES	1.10	1.30
	mm	28	33
C' (BA-150)	INCHES	1.10	1.45
	mm	28	37
D	INCHES	1.88	2.14
	mm	48	54
E	INCHES	3.81	4.62
	mm	97	117
F	THREADED INLET	NPT	NPT
Cv		13	30

Note: DN (Diameter Nominal) = Metric equivalent size.

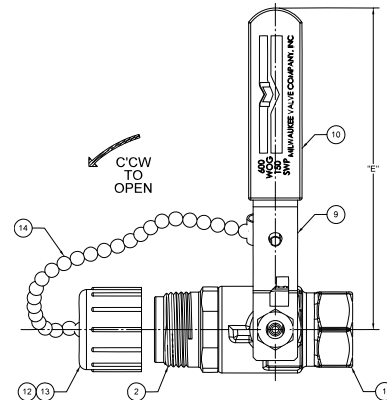

## PRESSURE - TEMPERATURE DATA (See Note)

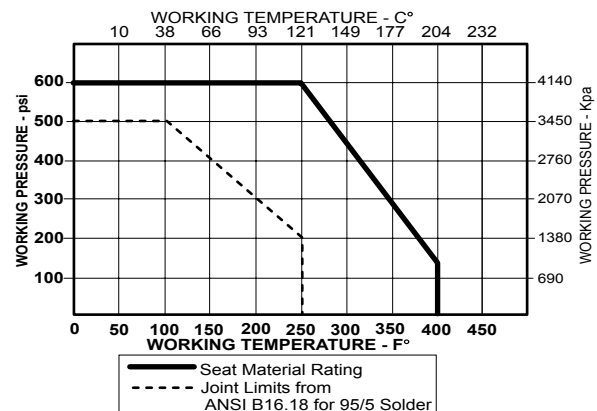

The information presented on this sheet is correct at the time of publication. Milwaukee Valve reserves the right to change design, and/or material specifications without notice. For the Installation, Operation and Maintenance Manual (IOM) see the Technical/Service Information section on our website. For the most current information access [www.milwaukeevalve.com](http://www.milwaukeevalve.com)



# BA-100SH/150SH\* 1/2"-3/4"

**Bronze Ball Valve**  
**Two Piece**  
**Full Port**  
**Threaded x 3/4" Hose End (BA100SH)**  
**Solder x 3/4" Hose End (BA150SH)**  
**Dust Cap and Chain**  
**Blow-Out Proof Stem**  
**MSS SP-110**

\*Not intended for use in potable water.

## MATERIALS LIST

ITEM	PART	MATERIALS	ASTM SPEC.
1	Body	Bronze	B584
2	Tailpiece	Brass	B16
3	Ball	316 Stainless Steel	A276
4	Seat	RPTFE, 15% Glass Filled	
5	Stem	316 Stainless Steel	A276
6	Thrust Washer	RPTFE, 25% Glass Filled	
7	Packing	PTFE	
8	Packing Nut	Brass	B16
9	Handle	Steel w/Zinc Plating	Commercial
10	Hand Grip	Vinyl	
11	Handle Nut	Steel w/Zinc Plating	Commercial
12	Dust Cap	Polypropylene	
13	Gasket	EPDM	
14	Chain	Brass Bead	

NOTE: Pressure / Temperature ratings shown are for valve only.  
Hose side pressure and temperature limit is based on connected hose and is the users responsibility.

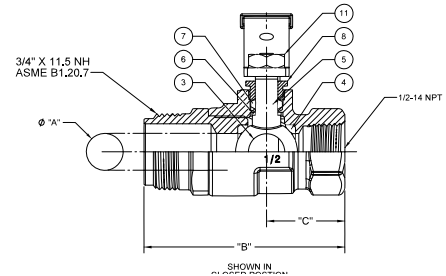
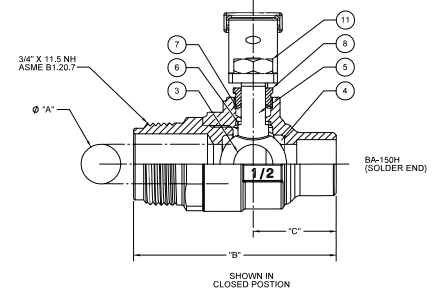

**Do not pressurize cap.**  
**Pressure not to exceed 40 psi.**

## DIMENSIONS

ØA	UNITS	1/2" DN15	3/4" DN20
	INCHES	0.50	0.76
	mm	13	19
B (BA-100)	INCHES	2.70	2.90
	mm	69	74
B' (BA-150)	INCHES	2.55	3.05
	mm	65	78
C (BA-100)	INCHES	1.10	1.30
	mm	28	33
C' (BA-150)	INCHES	1.10	1.45
	mm	28	37
D	INCHES	1.88	2.14
	mm	48	54
E	INCHES	3.81	4.62
	mm	97	117
F	THREADED INLET	NPT	NPT
Cv		13	30

Note: DN (Diameter Nominal) = Metric equivalent size.

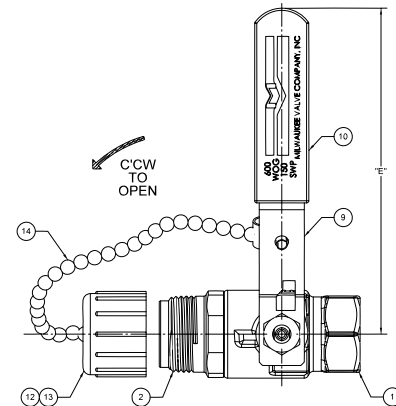

## PRESSURE - TEMPERATURE DATA (See Note)

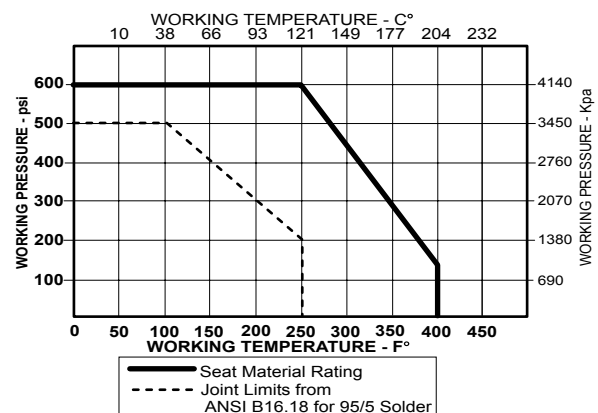

The information presented on this sheet is correct at the time of publication. Milwaukee Valve reserves the right to change design, and/or material specifications without notice. For the Installation, Operation and Maintenance Manual (IOM) see the Technical/Service Information section on our website. For the most current information access [www.milwaukeevalve.com](http://www.milwaukeevalve.com)



# BA-100H/100SH P1 1/2"-3/4"



**Bronze Ball Valve**  
**Two Piece**  
**Full Port**  
**250 psig @ 250°F†**  
**Press x Hose End**  
**Dust Cap and Chain**  
**Blow-Out Proof Stem**  
**Conforms to MSS SP-110**

\*Not intended for use in potable water.

## MATERIAL LIST

ITEM	PART	MATERIAL	ASTM SPEC
1	Body	Bronze	B584
2	Tailpiece	Brass	B16
3	Ball	Brass w/Hard Chrome Plating	B16
		316 Stainless Steel (1)	A276
4	Seat	RPTFE, 15% Glass Filled	
5	Stem	Brass	B16
		316 Stainless Steel (1)	A276
6	Thrust Washer	RPTFE, 25% Glass Filled	
7	Packing	PTFE	
8	Packing Nut	Brass	B16
9	Handle	Steel w/Zinc Plating	Commercial
10	Hand Grip	Vinyl	
11	Handle Nut	Steel w/Zinc Plating	Commercial
12	Dust Cap	Polypropylene	
13	Gasket	EPDM	
14	Chain	Brass Bead	
15	Press Adapters	Brass Fitting w/EPDM O-Ring	B283

+NON-SHOCK

(1) Ball & Stem are stainless steel for BA100SH P1

**Do not pressurize cap.**  
**Pressure not to exceed 40 psi.**

## DIMENSIONS

	UNITS	1/2"	3/4"
		DN15	DN20
A	INCHES mm	0.50 13	.76 19
B	INCHES mm	2.70 69	2.90 74
STD INSERTION DEPTH	INCHES mm	.87 22	.98 25
C	INCHES mm	1.10 28	1.30 33
D	INCHES mm	1.88 48	2.14 54
E	INCHES mm	3.81 97	4.62 117
F	THREAD INLET	NPT	NPT
Cv		13	30

Note: DN (Diameter Nominal) = Metric equivalent size.

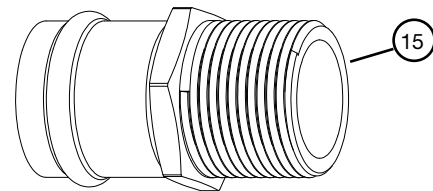
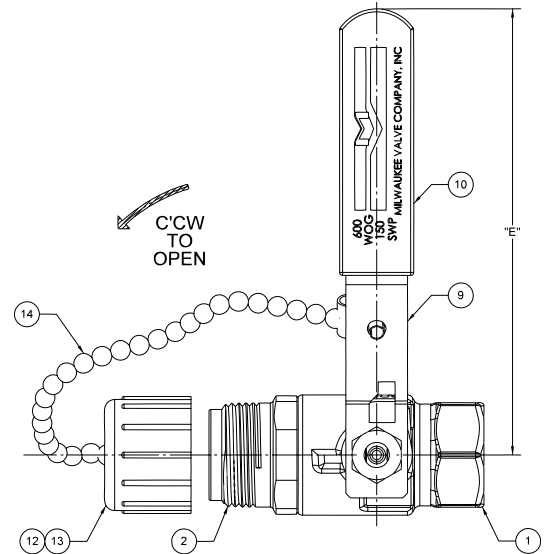
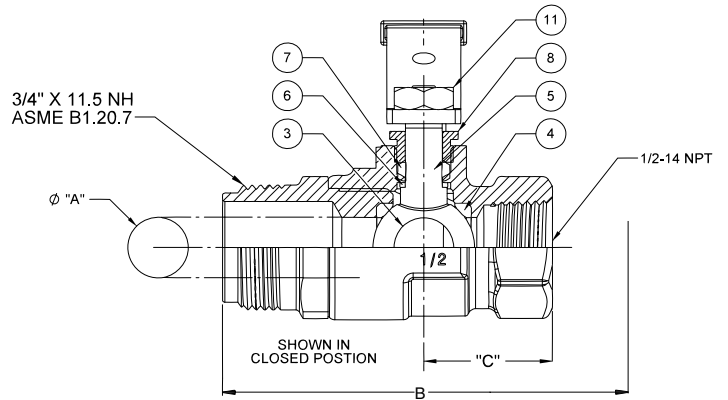

Press End Adapter (4151 Series)

The information presented on this sheet is correct at the time of publication. Milwaukee Valve reserves the right to change design, and/or material specifications without notice. For the Installation, Operation and Maintenance Manual (IOM) see the Technical/Service Information section on our website. For the most current information access [www.milwaukeevalve.com](http://www.milwaukeevalve.com)



# BA-100-M\* 1/4"-2"

**Bronze Ball Valve**  
**Two Piece**  
**Standard Port (1" - 2") Full Port (1/4" - 3/4")**  
**600 WOG/150 SWP\***  
**FNPT x MNPT Connections**  
**Blow-Out Proof Stem**  
**MSS SP-110**

\*Not intended for use in potable water.

## MATERIALS LIST

ITEM	PART	MATERIALS	ASTM SPEC.
1	Body	Cast Bronze	B584
2	Tailpiece	Brass/Bronze (1" & up)	B16/B584
3	Ball	Brass w/Hard Chrome Plating	B16
4	Seat	RPTFE, 15% Glass Filled	
5	Stem	Brass	B16
6	Thrust Washer	RPTFE, 25% Glass Filled	
7	Packing	PTFE	
8	Packing Nut	Brass	B16
9	Handle	Steel w/Zinc Plating	Commercial
10	Hand Grip	Vinyl	
11	Handle Nut	Steel w/Zinc Plating	Commercial

\* Please consult factory for more information regarding steam applications.

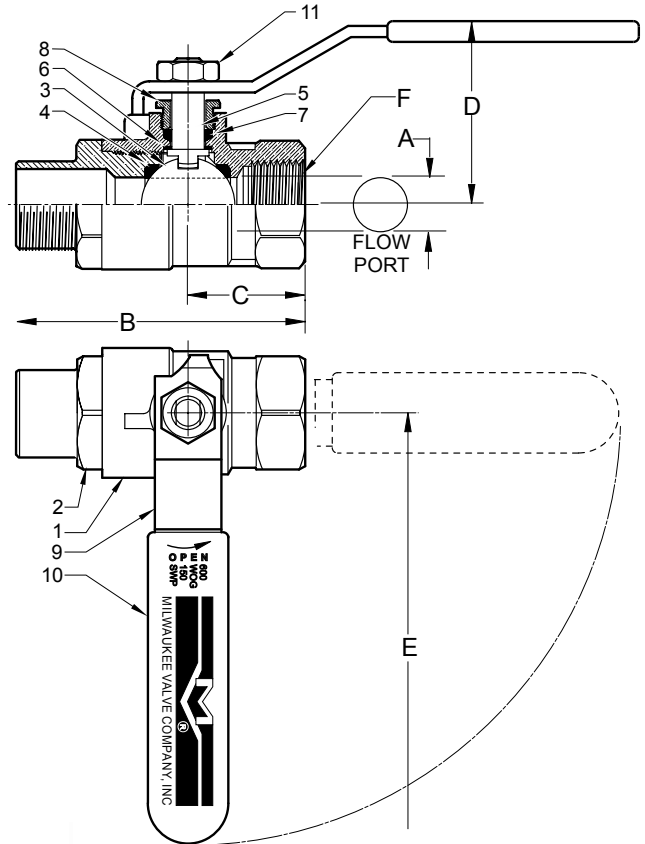

## PRESSURE - TEMPERATURE CHART

VALVES RATED FOR VACUUM SERVICE TO 29 INCHES Hg.

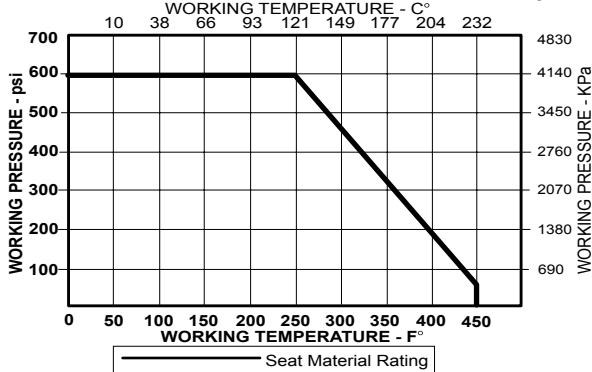

## DIMENSIONS

	UNITS	1/4" DN6	3/8" DN10	1/2" DN15	3/4" DN20	1" DN25	1-1/4" DN32	1-1/2" DN40	2" DN50
A (DIA)	INCHES	0.38	0.38	0.50	0.76	0.88	1.06	1.31	1.56
	mm	10	10	13	19	22	27	33	40
B	INCHES	2.50	2.52	2.80	3.22	3.64	4.24	4.69	4.95
	mm	64	64	71	82	93	108	119	126
C	INCHES	1.00	1.00	1.09	1.30	1.59	1.75	1.97	2.15
	mm	25	25	28	33	40	45	50	55
D	INCHES	1.76	1.76	1.87	2.20	2.28	2.67	2.77	3.00
	mm	45	45	48	56	58	68	70	77
E	INCHES	3.79	3.79	3.80	4.55	4.54	6.32	6.32	7.20
	mm	96	96	96	116	115	161	161	183
F	THREAD SIZE	1/4" NPT	3/8" NPT	1/2" NPT	3/4" NPT	1" NPT	1-1/4" NPT	1-1/2" NPT	2" NPT
Cv		11	11	17	30	40	52	90	115

Note: DN (Diameter Nominal) = Metric equivalent size.

The information presented on this sheet is correct at the time of publication. Milwaukee Valve reserves the right to change design, and/or material specifications without notice. For the Installation, Operation and Maintenance Manual (IOM) see the Technical/Service Information section on our website. For the most current information access [www.milwaukeevalve.com](http://www.milwaukeevalve.com)





# BA-100-TS\* 1/2"-2"

**Bronze Ball Valve**  
**Two Piece**  
**Standard Port (1" - 2") Full Port (1/2" - 3/4")**  
**600 WOG**  
**Threaded x Solder Ends**  
**Blow-Out Proof Stem**  
**MSS SP-110**

\*Not intended for use in potable water.

## MATERIALS LIST

ITEM	PART	MATERIALS	ASTM SPEC.
1	Body	Cast Bronze	B584
2	Tailpiece	Brass/Bronze (1" & up)	B16/B584
3	Ball	Brass w/Hard Chrome Plating	B16
4	Seat	RPTFE, 15% Glass Filled	
5	Stem	Brass	B16
6	Thrust Washer	RPTFE, 25% Glass Filled	
7	Packing	PTFE	
8	Packing Nut	Brass	B16
9	Handle	Steel w/Zinc Plating	Commercial
10	Hand Grip	Vinyl	
11	Handle Nut	Steel w/Zinc Plating	Commercial

\* Please consult factory for more information regarding steam applications.

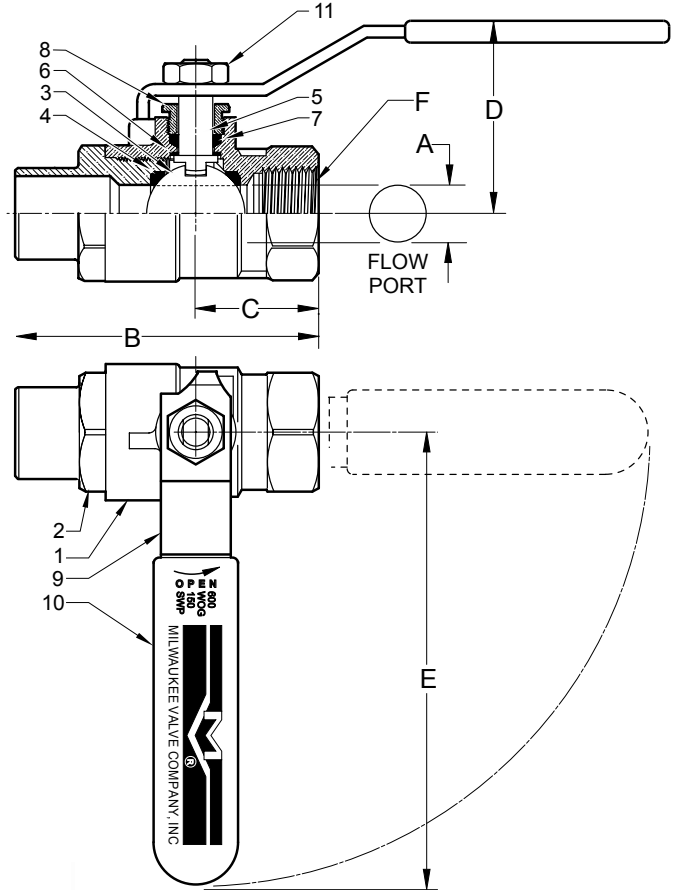

## PRESSURE - TEMPERATURE DATA

VALVES RATED FOR VACUUM SERVICE TO 29 INCHES Hg.

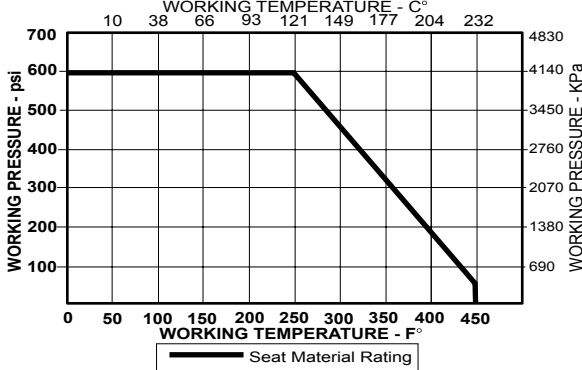

## DIMENSIONS

	UNITS	1/2" DN15	3/4" DN20	1" DN25	1-1/4" DN32	1-1/2" DN40	2" DN50
A (DIA)	INCHES	0.50	0.76	0.88	1.06	1.31	1.56
	mm	13	19	22	27	33	40
B	INCHES	2.16	2.91	3.53	4.00	4.46	5.27
	mm	55	74	90	102	113	134
C	INCHES	1.07	1.30	1.58	1.74	1.97	2.15
	mm	27	33	40	44	50	55
D	INCHES	1.87	2.08	2.25	2.66	2.84	3.00
	mm	48	53	57	67	72	76
E	INCHES	3.19	4.84	4.84	6.35	6.35	7.20
	mm	81	123	123	161	161	183
F	THREAD SIZE	1/2" NPT	3/4" NPT	1" NPT	1-1/4" NPT	1-1/2" NPT	2" NPT
Cv		13	30	40	52	90	115

Note: DN (Diameter Nominal) = Metric equivalent size.

The information presented on this sheet is correct at the time of publication. Milwaukee Valve reserves the right to change design, and/or material specifications without notice. For the Installation, Operation and Maintenance Manual (IOM) see the Technical/Service Information section on our website. For the most current information access [www.milwaukeevalve.com](http://www.milwaukeevalve.com)



# BA-150/150S\* 3/8"-3"

**Bronze Ball Valve**  
**Two Piece**  
**Standard Port (1" - 3") Full Port (3/8" - 3/4")**  
**600 WOG**  
**Solder Ends**  
**Blow-Out Proof Stem**  
**MSS SP-110**

\*Not intended for use in potable water.

## MATERIALS LIST

ITEM	PART	MATERIALS	ASTM SPEC.
1	Body	Cast Bronze	B584
2	Tailpiece	Brass	B283
		Cast Bronze (1 1/4" & up)	B584
3	Ball	Brass w/Hard Chrome Plating	B16
		316 Stainless Steel (1)	A276
4	Seat	RPTFE, 15% Glass Filled	
5	Stem	Brass	B16
		316 Stainless Steel (1)	A276
6	Thrust Washer	RPTFE, 25% Glass Filled	
7	Packing	PTFE	
8	Packing Nut	Brass	B16
9	Handle	Steel w/Zinc Plating	Commercial
10	Hand Grip	Vinyl	
11	Handle Nut	Steel w/Zinc Plating	Commercial

(1) Stem is stainless for BA-150S and 2-1/2"-3" BA-150.

## PRESSURE - TEMPERATURE DATA

VALVES RATED FOR VACUUM SERVICE TO 29 INCHES Hg.

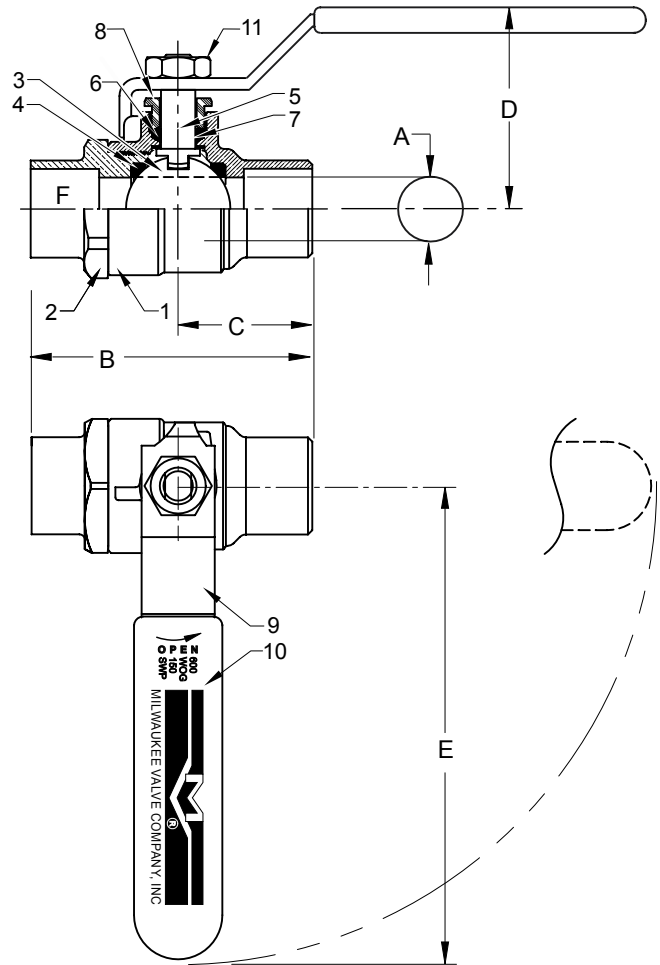
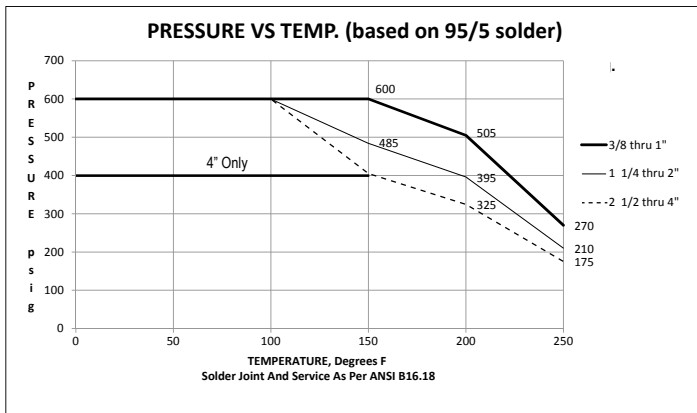

## DIMENSIONS

	UNITS	3/8" DN10	1/2" DN15	3/4" DN20	1" DN25	1-1/4" DN32	1-1/2" DN40	2" DN50	2-1/2" DN65	3" DN80
A (DIA)	INCHES	0.38	0.50	0.76	0.88	1.06	1.31	1.56	2.00	2.31
	mm	10	13	19	22	27	33	40	51	59
B	INCHES	2.10	2.39	3.05	3.71	4.54	5.00	6.25	7.34	8.16
	mm	52	59	75	91	111	123	153	180	200
C	INCHES	0.90	1.07	1.56	1.76	2.27	2.50	3.13	3.67	4.07
	mm	22	26	38	43	56	61	77	90	100
D	INCHES	1.80	1.89	2.13	2.29	2.67	2.85	3.02	3.47	3.88
	mm	44	46	52	56	65	70	74	85	95
E	INCHES	3.81	3.81	4.56	4.56	6.31	6.31	7.19	7.19	7.19
	mm	93	93	112	112	155	155	176	176	176
F	TUBE SIZE	0.51	0.63	0.88	1.13	1.38	1.63	2.13	2.63	3.13
	Cv	7	13	35	38	61	87	121	228	305

Note: DN (Diameter Nominal) = Metric equivalent size.

The information presented on this sheet is correct at the time of publication. Milwaukee Valve reserves the right to change design, and/or material specifications without notice. For the Installation, Operation and Maintenance Manual (IOM) see the Technical/Service Information section on our website. For the most current information access [www.milwaukeevalve.com](http://www.milwaukeevalve.com)



# BA-200\* 1/4"-4"

**Brass Ball Valve**  
**Two Piece**  
**Standard Port (1/2" - 4") Full Port (1/4" - 3/8")**  
**400 WOG**  
**Threaded Ends**  
**Blow-Out Proof Stem**  
**MSS SP-110**

\*Not intended for use in potable water.

## MATERIALS LIST

ITEM	PART	MATERIALS	ASTM SPEC.
1	Body	Brass, Forged	B283
2	Tailpiece	Brass, Forged	B283
3	Ball	Brass, CP	B283
		Brass CP, Cast	B584
4	Seat	PTFE	
5	Stem	Brass	B124
6	Thrust Washer	PTFE	
7	Gland Nut	Brass	B16
8	Gland Packing	PTFE	
9	Handle	Steel w/Zinc Plating	Commercial
10	Handle Nut	Brass	B16

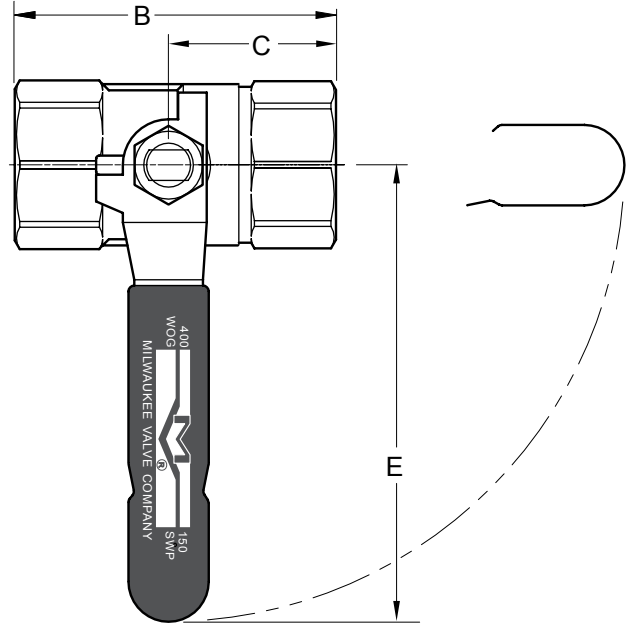

## PRESSURE - TEMPERATURE DATA

VALVES RATED FOR VACUUM SERVICE TO 29 INCHES Hg.

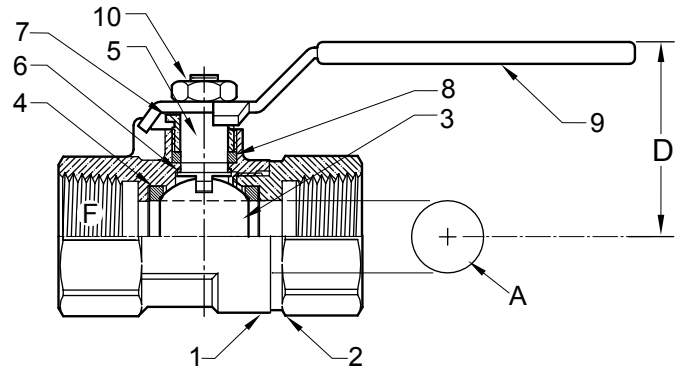
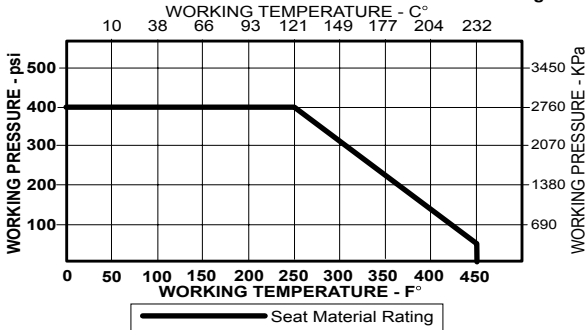

## DIMENSIONS

	UNITS	1/4" DN6	3/8" DN10	1/2" DN15	3/4" DN20	1" DN25	1-1/4" DN32	1-1/2" DN40	2" DN50	2-1/2" DN65	3" DN80	4" DN100
A (DIA)	INCHES	0.31	0.31	0.39	0.59	0.76	0.98	1.26	1.50	2.00	2.52	2.95
	mm	8	8	10	15	19	25	32	38	51	64	75
B	INCHES	1.65	1.65	2.30	2.55	3.05	3.43	3.76	4.21	5.50	6.22	7.31
	mm	42	42	58	65	78	87	96	107	140	158	186
C	INCHES	0.83	0.83	1.15	1.28	1.53	1.72	1.88	2.11	2.75	3.11	3.66
	mm	21	21	29	33	39	44	48	54	70	80	93
D	INCHES	1.38	1.38	1.50	1.61	2.00	2.17	2.72	2.87	3.66	4.02	4.33
	mm	35	35	38	41	51	55	69	73	93	102	110
E	INCHES	3.31	3.31	3.31	3.31	4.65	4.65	5.28	5.28	7.87	7.87	7.87
	mm	84	84	84	84	118	118	134	134	200	200	200
F	THREAD SIZE	1/4" NPT	3/8" NPT	1/2" NPT	3/4" NPT	1" NPT	1-1/4" NPT	1-1/2" NPT	2" NPT	2-2/1" NPT	3" NPT	4" NPT
Cv		9	9	12	18	40	72	112	161	287	448	645

Note: DN (Diameter Nominal) = Metric equivalent size.

The information presented on this sheet is correct at the time of publication. Milwaukee Valve reserves the right to change design, and/or material specifications without notice. For the Installation, Operation and Maintenance Manual (IOM) see the Technical/Service Information section on our website. For the most current information access [www.milwaukeevalve.com](http://www.milwaukeevalve.com)



# BA-250\* 3/8"-3"

Brass Ball Valve  
 Two Piece  
 Standard Port (3/4" -3") Full Port (3/8" )  
 400 WOG  
 Solder Ends  
 Blow-Out Proof Stem  
 MSS SP-110

\*Not intended for use in potable water.

## MATERIALS LIST

ITEM	PART	MATERIALS	ASTM SPEC.
1	Body	Brass, Forged	B283
2	Tailpiece	Brass, Forged	B283
3	Ball	Brass, CP	B283
		Brass CP, Cast	B584
4	Seat	PTFE	
5	Stem	Brass	B124
6	Thrust Washer	PTFE	
7	Gland Nut	Brass	B16
8	Gland Packing	PTFE	
9	Handle	Steel w/Zinc Plating	Commercial
10	Handle Nut	Brass	B16

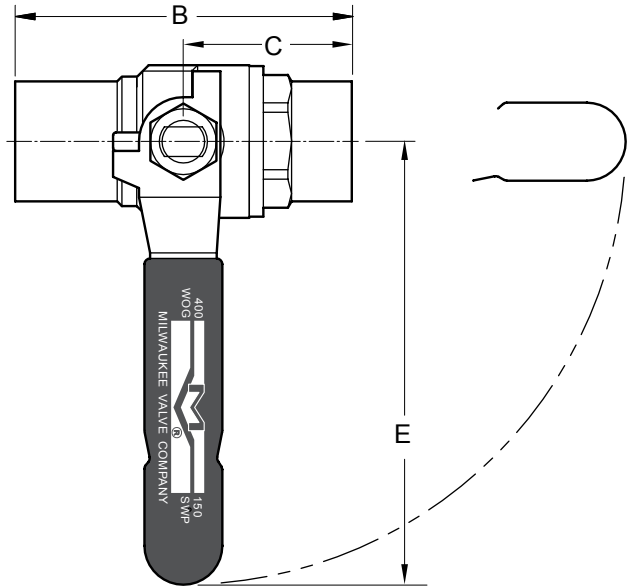

## PRESSURE - TEMPERATURE DATA

VALVES RATED FOR VACUUM SERVICE TO 29 INCHES Hg.  
 WORKING TEMPERATURE - C°  
 10 38 66 93 121 149 177 204 232

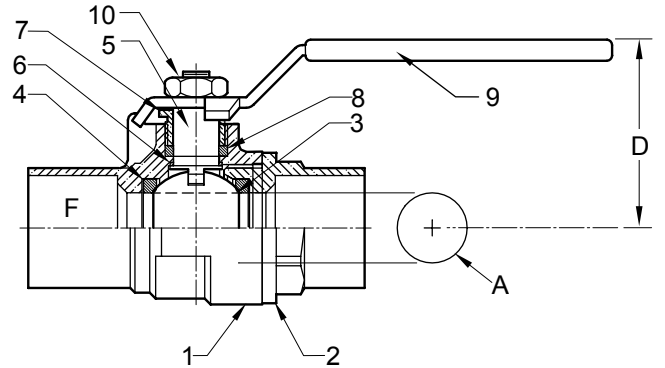
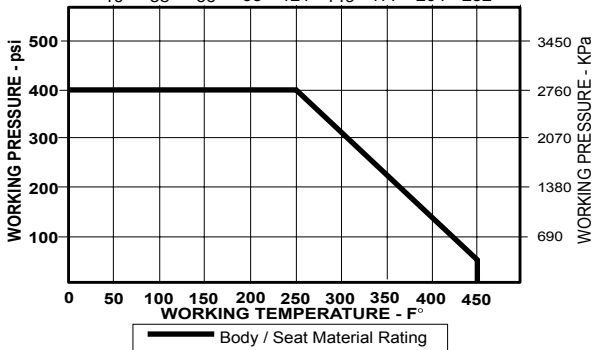

## DIMENSIONS

	UNITS	3/8" DN10	1/2" DN15	3/4" DN20	1" DN25	1-1/4" DN32	1-1/2" DN40	2" DN50	2-1/2" DN65	3" DN80
A (DIA)	INCHES	0.31	0.39	0.59	0.76	0.98	1.26	1.50	2.00	2.52
	mm	8	10	15	19	25	32	38	51	64
B	INCHES	1.75	2.19	2.83	3.44	3.85	4.43	5.23	5.94	6.97
	mm	45	56	72	87	98	113	133	151	177
C	INCHES	0.88	1.14	1.42	1.72	1.93	2.23	2.62	2.97	3.49
	mm	22	29	36	44	49	57	67	75	89
D	INCHES	1.38	1.50	1.61	2.00	2.17	2.72	2.87	3.66	4.02
	mm	35	38	41	51	55	69	73	93	102
E	INCHES	3.31	3.31	3.31	4.65	4.65	5.28	5.28	7.87	7.87
	mm	84	84	84	118	118	134	134	200	200
F	TUBE SIZE Ø	0.51	0.63	0.88	1.13	1.38	1.63	2.13	2.63	3.13
Cv		9	12	18	40	72	112	161	287	448

Note: DN (Diameter Nominal) = Metric equivalent size.

The information presented on this sheet is correct at the time of publication. Milwaukee Valve reserves the right to change design, and/or material specifications without notice. For the Installation, Operation and Maintenance Manual (IOM) see the Technical/Service Information section on our website. For the most current information access [www.milwaukeevalve.com](http://www.milwaukeevalve.com)



# BA-300/300S\* 1/4"-3"

**Bronze Ball Valve**  
**Three Piece**  
**Full Port**  
**600 WOG/150 SWP (1)**  
**Threaded Ends**  
**Blow-Out Proof Stem**  
**MSS SP-110**

\*Not intended for use in potable water.

## MATERIALS LIST

ITEM	PART	MATERIALS	ASTM SPEC.
1	Body	Cast Bronze	B584
2	End Cap	Bronze	B584
3	Stem	Brass	B16
		316 Stainless Steel (2)	A276
4	Packing Nut	Brass	B16
5	Packing	PTFE	
6	Thrust Washer	RPTFE, 25% Glass Filled	
7	Ball	CP Brass	B16
		316 Stainless Steel (2)	A276
8	Seat	RPTFE, 15% Glass Filled	
9	O-Ring	Viton	Commercial
10	Handle	Steel w/Zinc Plating	Commercial
11	Handle Grip	Vinyl	Commercial
12	Handle Nut	Steel w/Zinc Plating	Commercial
13	Bolt	Steel w/Zinc Plating	Commercial
14	Nut	Steel w/Zinc Plating	Commercial

(1) Milwaukee Valve Company recommends the use of Stainless Steel ball and stem for steam applications. Please consult factory for more information.

(2) Ball and stem are stainless for 300S

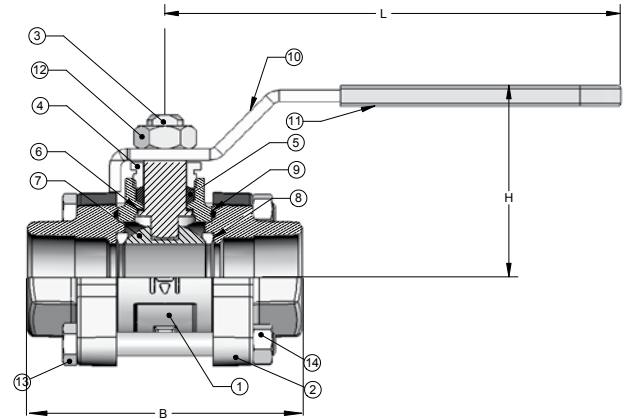

## PRESSURE and TEMPERATURE CHART

VALVES RATED FOR VACUUM SERVICE TO 29 INCHES Hg.

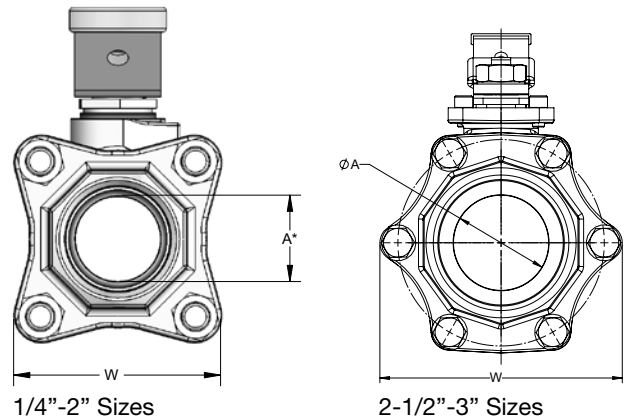
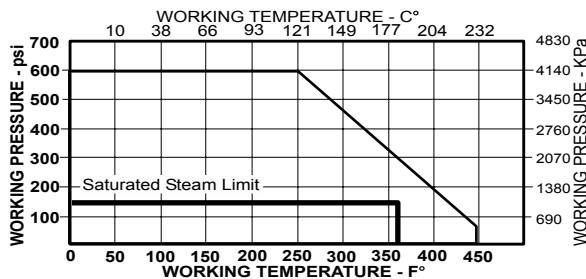

## DIMENSIONS

	UNITS	1/4" DN6	3/8" DN10	1/2" DN15	3/4" DN20	1" D25	1-1/4" D32	1-1/2" D40	2" D50	2-1/2" DN 65	3" * DN 80
A	INCHES	0.50	0.50	0.50	0.75	1	1.25	1.50	2.00	2.50	2.50
	mm	13	13	13	19	25	32	38	51	64	64
B	INCHES	3.03	3.03	3.03	3.65	3.82	4.86	5.06	6.00	7.00	7.00
	mm	77	77	77	90	97	123	129	152	178	178
H	INCHES	1.65	1.65	1.65	2.24	2.65	2.86	3.03	3.26	4.09	4.09
	mm	42	42	42	57	67	73	77	83	104	104
L	INCHES	4.03	4.03	4.06	4.58	6.30	6.32	7.20	7.20	8.00	8.00
	mm	102	102	103	116	160	161	183	183	203	203
W	INCHES	1.95	1.95	1.95	2.19	2.48	3.00	3.13	3.78	6.25	6.25
	mm	50	50	50	56	63	76	80	96	159	159
F	THREAD SIZE	1/4" NPT	3/8" NPT	1/2" NPT	3/4" NPT	1" NPT	1-1/4" NPT	1-1/2" NPT	2" NPT	2-1/2" NPT	3" NPT
Cv		7	7	17	31	60	110	185	360	390	390

Note: DN (Diameter Nominal) = Metric equivalent size.

\* 3" is Standard Port.

The information presented on this sheet is correct at the time of publication. Milwaukee Valve reserves the right to change design, and/or material specifications without notice. For the Installation, Operation and Maintenance Manual (IOM) see the Technical/Service Information section on our website. For the most current information access [www.milwaukeevalve.com](http://www.milwaukeevalve.com)



# BA-300/300S\* P2 1/2"-2"



**Bronze Ball Valve**  
**Three Piece**  
**Full Port**  
**250 psig @ 250°F†**  
**Press x Press Ends**  
**Press x Threaded Ends Available (Consult Factory)**  
**Blow-Out Proof Stem**  
**Conforms to MSS SP-110**

\*Not intended for use in potable water.

## MATERIAL LIST

ITEM	PART	MATERIAL	ASTM SPEC
1	Body	Bronze	B584
2	End Cap	Bronze	B584
3	Stem	Brass	B16
		316 Stainless Steel (2)	A276
4	Packing Nut	Brass	B16
5	Packing	PTFE	
6	Thrust Washer	RPTFE, 25% Glass Filled	
7	Ball	CP Brass	B16
		316 Stainless Steel (1)	A276
8	Seat	RPTFE, 15% Glass Filled	
9	O'Ring	Viton	Commercial
10	Handle	Steel w/Zinc Plating	Commercial
11	Hand Grip	Vinyl	Commercial
12	Handle Nut	Steel w/Zinc Plating	Commercial
13	Bolt	Steel w/Zinc Plating	Commercial
14	Nut	Steel w/Zinc Plating	Commercial
15	Press Adapters	Brass Fitting w/EPDM O-Ring	B283

(1) Ball & Stem are stainless steel for BA300S P2

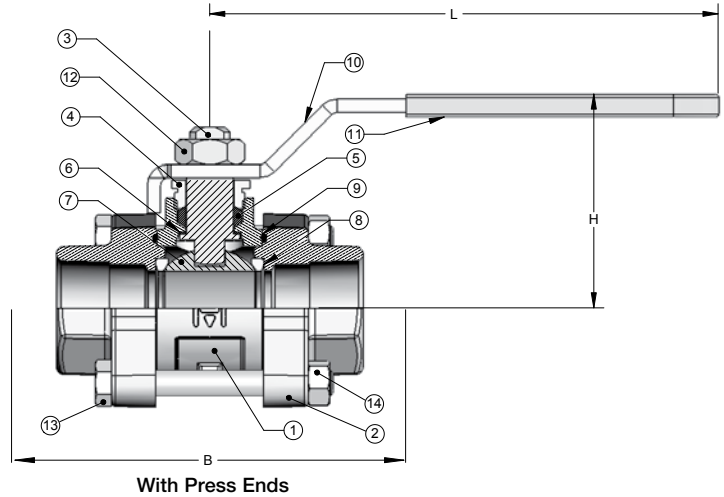

With Press Ends

## DIMENSIONS

	UNITS	1/2" DN15	3/4" DN20	1" DN25	1-1/4" DN32	1-1/2" DN40	2" DN50
	A (DIA)	INCHES	0.50	0.75	1.00	1.25	1.50
	mm	13	19	25	32	38	51
STD INSERTION DEPTH	INCHES	0.87	0.98	0.98	1.02	1.42	1.58
	mm	22	25	25	26	36	40
B	INCHES	3.03	3.65	3.82	4.86	5.06	6.00
	mm	77	90	97	123	129	152
H	INCHES	1.65	2.24	2.65	2.86	3.03	3.26
	mm	42	57	67	73	77	83
L	INCHES	4.06	4.58	6.30	6.32	7.20	7.20
	mm	103	116	160	161	183	183
W	INCHES	1.95	2.19	2.48	3.00	3.13	3.78
	mm	50	56	63	76	80	96
F	THREAD SIZE	1/2"	3/4"	1"	1 1/4"	1 1/2"	2"
		NPT	NPT	NPT	NPT	NPT	NPT
Cv	INCHES	17	31	60	110	185	360

Note: DN (Diameter Nominal) = Metric equivalent size.

+Non-Shock

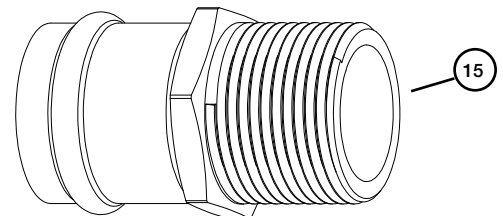
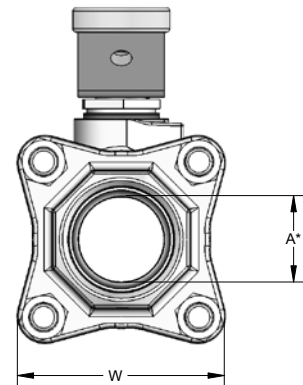

Press End Adapter (4151 SERIES)

The information presented on this sheet is correct at the time of publication. Milwaukee Valve reserves the right to change design, and/or material specifications without notice. For the Installation, Operation and Maintenance Manual (IOM) see the Technical/Service Information section on our website. For the most current information access [www.milwaukeevalve.com](http://www.milwaukeevalve.com)



# BA-300SB/300SBS\*\* 3/4"-2"

**Bronze Ball Valve\*\*\***  
**Three Piece**  
**Full Port**  
**600 WOG/150 SWP (1)**  
**Silbraze Ends**  
**Blow-Out Proof Stem**  
**MSS SP-110**

\*Not intended for use in potable water.

## MATERIALS LIST

ITEM	PART	MATERIALS	ASTM SPEC.
1	Body	Cast Bronze	ASTM B61/ B62
2	End Cap	Cast Bronze	ASTM B61/ B62
3	Stem	316 Stainless Steel	ASTM A276
4	Packing	PTFE	
5	Packing Nut	Brass	ASTM B16
6	Thrust Washer	RPTFE 25% Glass Reinforced	
7	Ball	Stainless Steel	ASTM A276
8	Seat	RPTFE 15% Glass Reinforced	
9	O-ring	Viton®	Commercial
10	Handle	Stainless Steel	Commercial
11	Handle Grip	Vinyl	
12	Handle Nut	Stainless Steel	Commercial
13	Bolt	Stainless Steel Type 304	ASTM F593
14	Nut	Stainless Steel Type 304	ASTM F594

(1) Milwaukee Valve Company recommends the use of Stainless Steel ball and stem for steam applications. Please consult factory for more information.  
 (2) Ball and stem are stainless for 300SBS

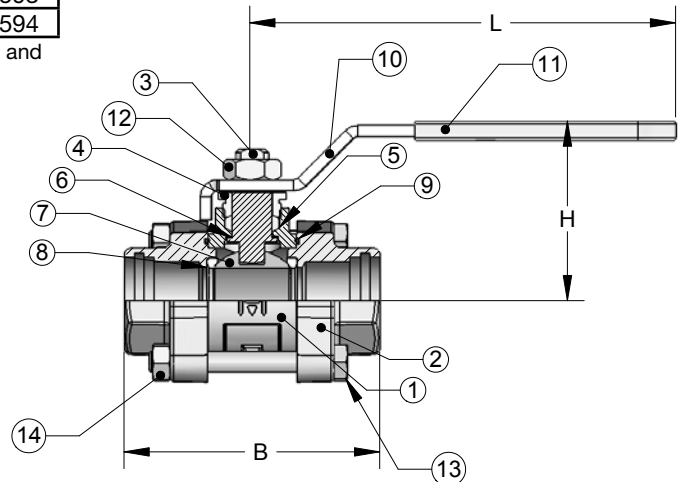
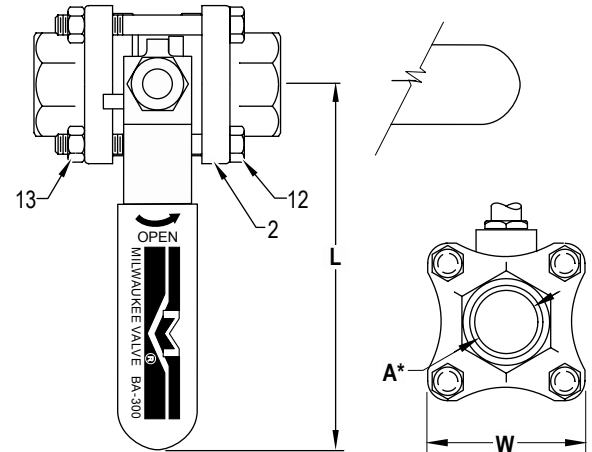

\*\* Pressure temperature charts contain valve seat and body ratings for standard valves using normal solder installation techniques. Solder end valves are de-rated by the limitations of the joint as specified in ASME 16.18. Brazing installations can have the same effect on the valve rating. Consult ASME 16.18 and the American Welding Society for the actual joint ratings of the material being used for the specific application.

## DIMENSIONS

	UNITS	1/4" DN6	3/8" DN10	1/2" DN15	3/4" DN20	1" DN25	1-1/4" DN32	1-1/2" DN40	2" DN50
A	INCHES	0.50	0.50	0.50	0.75	1.00	1.25	1.50	2.00
	mm	13	13	13	19	25	32	38	51
B	INCHES	3.03	3.03	3.03	3.56	3.82	4.86	5.06	6.00
	mm	77	77	77	90	97	123	129	152
H	INCHES	1.65	1.65	1.65	2.24	2.65	2.86	3.03	3.26
	mm	42	42	42	57	67	73	77	83
L	INCHES	4.03	4.03	4.06	4.58	6.30	6.32	7.20	7.20
	mm	102	102	103	116	160	161	183	183
W	INCHES	1.95	1.95	1.95	2.19	2.48	3.00	3.13	3.78
	mm	50	50	50	56	63	76	80	96
F	THREAD SIZE	1/4" NPT	3/8" NPT	1/2" NPT	3/4" NPT	1" NPT	1 1/4" NPT	1 1/2" NPT	2" NPT
Cv		7	7	17	31	60	110	185	360

Note: DN (Diameter Nominal) = Metric equivalent size.

The information presented on this sheet is correct at the time of publication. Milwaukee Valve reserves the right to change design, and/or material specifications without notice. For the Installation, Operation and Maintenance Manual (IOM) see the Technical/Service Information section on our website. For the most current information access [www.milwaukeevalve.com](http://www.milwaukeevalve.com)





# BA-350/350S\* 3/8"-3"

**Bronze Ball Valve  
Three Piece  
Full Port  
600 WOG  
Solder Ends  
Blow-Out Proof Stem  
MSS SP-110**

\*Not intended for use in potable water.

## MATERIALS LIST

ITEM	PART	MODEL/SIZE	MATERIALS	ASTM SPEC.
1	Body	350 & 350S	Cast Bronze	B584
2	Tailpiece	350 & 350S	Bronze	B584
3	Ball	350	Chrome Plated Brass	B16
		350S	316 Stainless Steel (1)	A276
4	Packing	350	Brass	B16
		350S	316 Stainless Steel (1)	A276
5	O-Ring	350 & 350S	Viton	MIL-R-83248
6	Seat	350 & 350S	15% Glass RPTFE	
7	Thrust, Washer	350 & 350S	25% Glass RPTFE	
8	Packing, Male	2-1/2"-3"	PTFE (2 1/2" - 3")	
	Packing, Female	3/8"-2"	PTFE (3/8" - 2")	
9	Packing, "V"	350 & 350S	PTFE	
10	Packing, Female	350 & 350S	PTFE	
11	Packing Follower	350 & 350S	Brass	B16
12	Hex Jam Nut	350 & 350S	Stainless Steel	Commercial
13	Nut Locker	350 & 350S	S.S. Type 301/302	
14	Washer, Internal Tooth	350 & 350S	Stainless Steel	Commercial
15	Belleville, Washer	350 & 350S	S.S. 17-7 PH	Commercial
16	Hex Head Cap Screw	350 & 350S	SAE, Grade 8	Commercial
17	Socket Head Cap Screw	2-1/2"-3"	Commercial Carbon Steel	Zinc Plated
18	Handle Assy	350 & 350S	-	-
19	Gland Nut	3/8"-2"	Brass	B16
20	Hex Nut	3/8"-2"	Commercial	SAE 5140

(1) Ball and stem are stainless for 350S

## PRESSURE and TEMPERATURE CHART

VALVES RATED FOR VACUUM SERVICE TO 29 INCHES Hg.  
 ——— Seat Material Rating  
 - - - - Solder Joints per ANSI B16.18

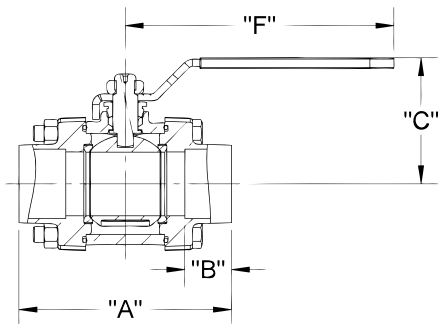
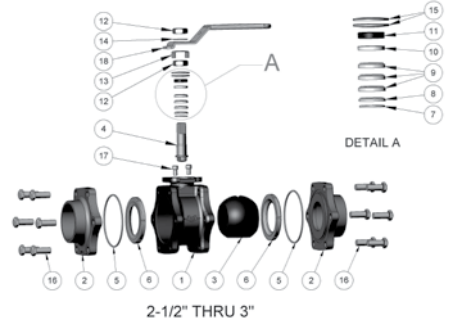
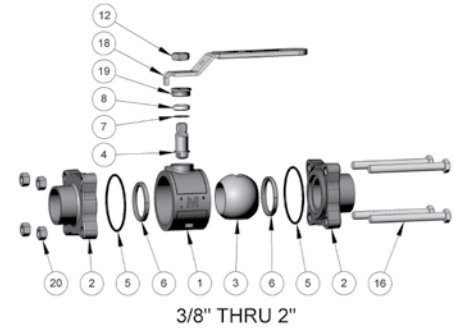
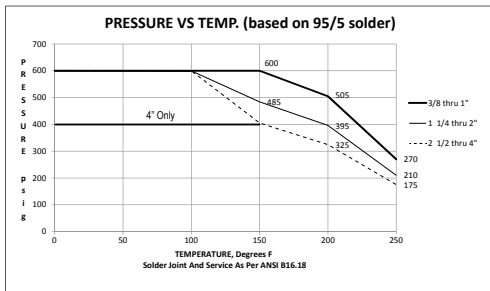

## DIMENSIONS

	UNITS	3/8" DN10	1/2" DN15	3/4" DN20	1" DN25	1-1/4" DN32	1-1/2" DN40	2" DN50	2-1/2" DN65	3" DN80
A	INCHES	2.68	3.02	3.56	3.81	4.66	5.00	5.70	7.01	7.01
	mm	68	77	90	97	118	127	145	178	178
B	INCHES	0.44	0.51	0.76	0.92	0.98	1.10	1.35	1.48	1.67
	mm	11	13	19	23	25	28	34	38	42
C	INCHES	1.85	1.85	2.20	2.65	2.79	2.97	3.47	5.44	5.44
	mm	47	47	56	67	71	75	88	138	138
D	INCHES	0.45	0.50	0.75	1.00	1.25	1.50	2.00	2.50	2.50
	mm	11	13	19	25	32	38	51	64	64
E	INCHES	1.32	1.32	2.13	2.41	2.94	3.13	3.86	5.74	5.74
	mm	34	34	54	61	75	80	98	146	146
F	INCHES	3.80	3.80	4.55	6.32	6.32	6.32	7.20	8.10	8.10
	mm	96	96	116	160	160	160	183	206	206
G	INCHES	1.92	1.92	2.13	2.41	2.94	3.13	3.86	6.31	6.31
	mm	49	49	54	61	75	80	98	160	160
Cv		7	17	31	60	110	185	360	390	390

\*3" is standard Port.

\*\*2-1/2" & 3" Only.

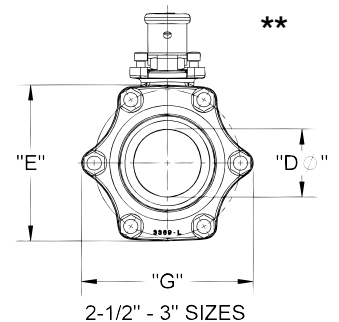

The information presented on this sheet is correct at the time of publication. Milwaukee Valve reserves the right to change design, and/or material specifications without notice. For the Installation, Operation and Maintenance Manual (IOM) see the Technical/Service Information section on our website. For the most current information access [www.milwaukeevalve.com](http://www.milwaukeevalve.com)





# BA-350TE/350STE\* 1/2"-3"

**Bronze Ball Valve  
Three Piece  
Full Port  
600 WOG  
Extended Tube Ends  
Inline Repairable  
Blow-Out Proof Stem  
MSS SP-110**

\*Not intended for use in potable water.

## MATERIALS LIST

ITEM	PART	MODEL/SIZE	MATERIALS	ASTM SPEC.
1	Body	BA350 & 350S	Bronze	B584
2	Sil. Braised Stub, Male	BA350 & 350S	Bronze, Copper Tube	
3	Ball	BA350	Chrome Plated Brass	B16
		BA350S	316 Stainless Steel (1)	A276
4	Stem	BA350	Brass	B16
		BA350 & 350S	316 Stainless Steel (1)	A276
5	Seat	BA350 & 350S	15% Glass RPTFE	
6	O-Ring	BA350 & 350S	Viton	MIL-R-83248
7	Washer, Thrust	BA350 & 350S	25% Glass RPTFE	
8	Packing	BA350 & 350S	PTFE	
	Packing, Male	BA350 & 350S	PTFE	
9	Packing, "V"	BA350 & 350S	PTFE	
10	Packing, Female	BA350 & 350S	PTFE	
11	Packing Follower	BA350 & 350S	Brass	B16
12	Washer, Belleville	BA350 & 350S	17-7 PH S.S.	Commercial
13	Nut Locker	BA350 & 350S	S.S. 301	Commercial
14	Handle Assy	350 & 350S	-	
15	Hex Head Cap Screw	BA350 & 350S	SAE, Grade 8	Commercial
16	Nut, Jam	BA350 & 350S	Steel, Zinc Plating	Commercial
17	Washer, Internal Tooth	BA350 & 350S	Stainless Steel	Commercial
18	Socket Head Cap Screw	2-1/2"-3"	Commercial Carbon Steel	Zinc Plated
19	Gland Nut	1/2"-2"	Brass	B16
20	Hex Nut	1/2"-2"	Commercial	SAE 5140

(1) Ball and stem are stainless for 350STE

\*\* Pressure temperature charts contain valve seat (1) Ball and stem are stainless for 350STE and body ratings for standard valves. Solder end valves are de-rated by the limitations of the joint as specified in ASME 16.18. Brazing installations can be likewise derated. Consult ASME 16.18 and the American Welding Society for the actual joint ratings of the material being used for the specific application. Pressure and Temperature ratings may be further derated in accordance with the pressure rating associated with the type of copper tube used for the stub end. Call the factory for accurate application data.

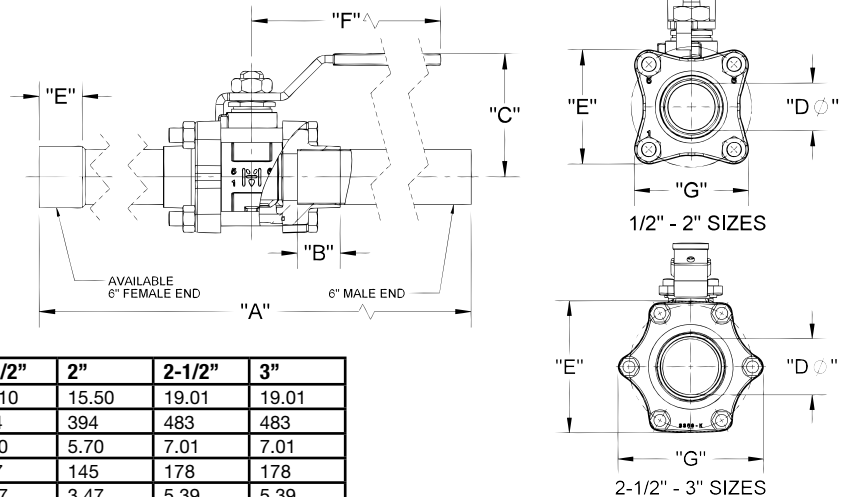

## DIMENSIONS

	UNITS	1/2"	3/4"	1"	1-1/4"	1-1/2"	2"	2-1/2"	3"
A	INCHES	13.84	13.92	13.95	14.82	15.10	15.50	19.01	19.01
	mm	352	354	354	376	384	394	483	483
B	INCHES	3.02	3.56	3.81	4.66	5.00	5.70	7.01	7.01
	mm	77	90	97	118	127	145	178	178
C	INCHES	1.85	2.20	2.65	2.80	2.97	3.47	5.39	5.39
	mm	47	56	67	71	75	88	137	137
ØD	INCHES	0.50	0.75	1.00	1.25	1.50	2.00	2.44	2.91
	mm	13	19	25	32	38	51	62	74
E	INCHES	1.32	2.13	2.41	2.94	3.13	3.86	5.74	5.74
	mm	34	54	61	75	80	98	146	146
F	INCHES	1.92	2.13	2.41	2.94	3.13	3.86	6.31	6.31
	mm	49	54	61	75	80	98	160	160
G	INCHES	3.80	4.56	6.32	6.32	6.32	7.20	8.10	8.10
	mm	97	116	161	161	161	183	206	206
Cv		17	31	60	110	185	360	390	390

Note: DN (Diameter Nominal) = Metric equivalent size.

\* Designed for soft solder or brazed installation without disassembly.

### Available Options

- Male Tube Ends - Type "K" (Standard)
- Female Tube Ends - Type "L" (-F)
- Cleaned For Oxygen Service In Accordance With NFPA 99C (-OC)
- Stainless-Steel Ball And Stem (-S)
- Stainless-Steel Locking Lever (-LD)
- Oval Handle (-OH)
- Oval Locking Handle (-LO)
- Stem Extension (-XH)
- Stainless-Steel Lever Handle (-SH)
- Gauge Ports

The information presented on this sheet is correct at the time of publication. Milwaukee Valve reserves the right to change design, and/or material specifications without notice. For the Installation, Operation and Maintenance Manual (IOM) see the Technical/Service Information section on our website. For the most current information access [www.milwaukeevalve.com](http://www.milwaukeevalve.com)



# BA-350TE-G/350STE-G\* 1/2"-2"

**Bronze Ball Valve  
Three Piece  
Full Port  
600 WOG  
Extended Tube Ends with 1/8" NPT Gauge Port  
Inline Repairable  
Blow-Out Proof Stem  
MSS SP-110**

**\*Not intended for use in potable water.**

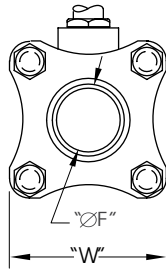

**Available Options**

- Male Tube Ends - Type "K" (Standard)
- Female Tube Ends - Type "L" (-F)
- Cleaned For Oxygen Service In Accordance With NFPA 99C (-OC)
- Stainless-Steel Ball And Stem (-S)
- Stainless-Steel Locking Lever (-LD)
- Oval Handle (-OH)
- Oval Locking Handle (-LO)
- Stem Extension (-XH)
- Stainless-Steel Lever Handle (-SH)

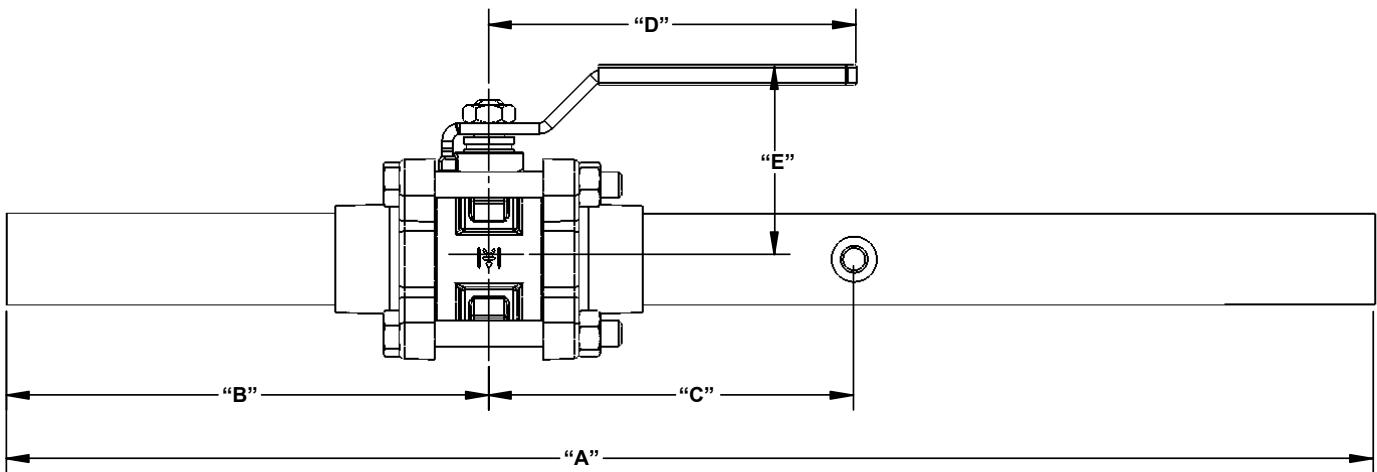

**DIMENSIONS**

	UNITS	1/2" DN15	3/4" DN20	1" DN25	1-1/4" DN32	1-1/2" DN40	2" DN50
A	INCHES	21.00	21.00	21.00	21.00	21.00	21.00
	mm	533	533	533	533	533	533
B	INCHES	6.90	7.00	7.00	7.40	7.60	7.70
	mm	175	178	178	188	193	196
C	INCHES	6.40	6.10	5.90	5.50	5.40	5.00
	mm	163	155	150	140	137	127
D	INCHES	3.80	4.80	4.80	6.50	7.40	7.40
	mm	97	122	122	165	188	188
E	INCHES	1.60	2.30	2.40	2.80	3.10	3.60
	mm	41	58	61	71	79	91
F	INCHES	0.50	0.75	1.00	1.25	1.50	2.00
	mm	13	19	25	32	38	51
G	INCHES	1.90	2.20	2.50	3.00	3.00	4.00
	mm	48	56	64	76	76	102
Cv		17	31	60	110	185	360

Note: DN (Diameter Nominal) = Metric equivalent size.

\*\* Pressure temperature charts contain valve seat (1) Ball and stem are stainless for 350STE and body ratings for standard valves. Solder end valves are de-rated by the limitations of the joint as specified in ASME 16.18. Brazing installations can be likewise derated. Consult ASME 16.18 and the American Welding Society for the actual joint ratings of the material being used for the specific application. Pressure and Temperature ratings may be further derated in accordance with the pressure rating associated with the type of copper tube used for the stub end. Call the factory for accurate application data.

The information presented on this sheet is correct at the time of publication. Milwaukee Valve reserves the right to change design, and/or material specifications without notice. For the Installation, Operation and Maintenance Manual (IOM) see the Technical/Service Information section on our website. For the most current information access [www.milwaukeevalve.com](http://www.milwaukeevalve.com)



# BA-400/400S\* 1/4"-2"

**Bronze Ball Valve**  
**Two Piece**  
**Full Port**  
**600 WOG/150 SWP (1)**  
**Threaded Ends**  
**Blow-Out Proof Stem**  
**MSS SP-110**

\*Not intended for use in potable water.

## MATERIALS LIST

ITEM	PART	MATERIALS	ASTM SPEC.
1	Body	Cast Bronze	B584
2	Tailpiece	Brass	B283
		Cast Bronze (1 1/4" & up)	B584
3	Ball	Brass w/Hard Chrome Plating	B16
		316 Stainless Steel (BA-400S)	A276
4	Seat	RPTFE, 15% Glass Filled	
5	Stem	Brass	B16
		316 Stainless Steel (BA-400S)	A276
6	Thrust Washer	RPTFE, 25% Glass Filled	
7	Packing	PTFE	
8	Packing Nut	Brass	B16
9	Handle	Steel w/Zinc Plating	Commercial
10	Hand Grip	Vinyl	
11	Handle Nut	Steel w/Zinc Plating	Commercial

(1) For steam service please specify see BA400S3.

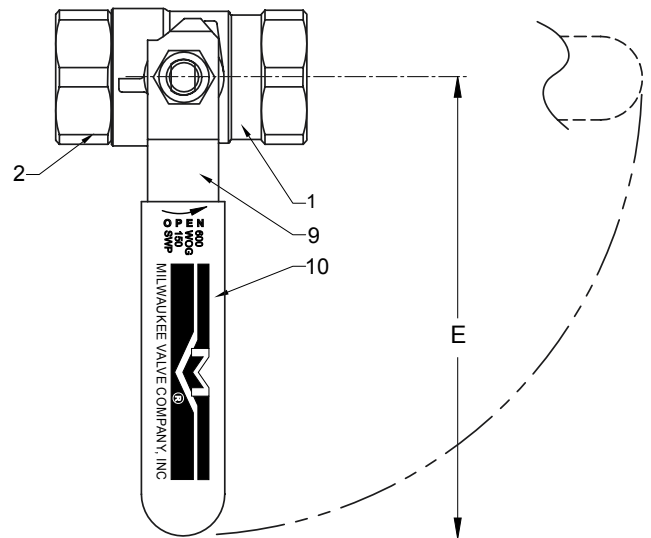
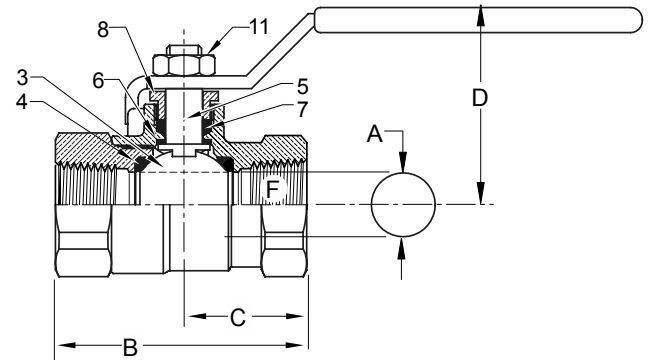
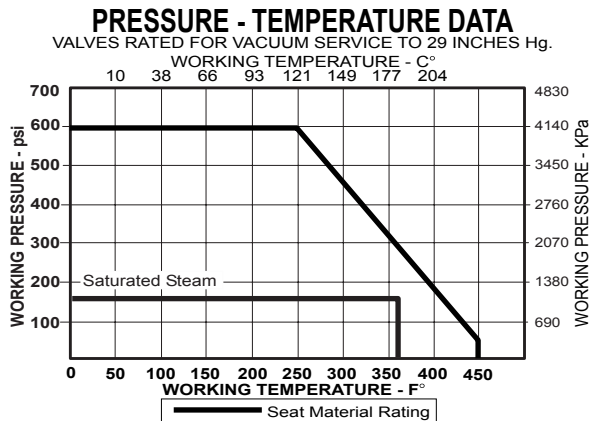

## DIMENSIONS

	UNITS	1/4"	3/8"	1/2"	3/4"	1"	1-1/4"	1-1/2"	2"
		DN10	DN10	DN15	DN20	DN25	DN32	DN40	DN50
A (DIA)	INCHES	0.38	0.38	0.50	0.76	1.06	1.31	1.56	2.00
	mm	10	10	13	19	27	33	40	51
B	INCHES	1.86	1.86	2.19	2.59	3.32	3.77	4.28	5.10
	mm	46	46	54	66	84	96	109	130
C	INCHES	1.00	1.00	1.10	1.30	1.59	1.81	2.06	2.37
	mm	25	25	27	33	40	46	52	60
D	INCHES	1.78	1.81	1.91	2.32	2.68	2.82	3.00	3.36
	mm	44	44	47	59	68	72	76	85
E	INCHES	3.82	3.82	3.82	4.55	6.33	6.33	6.33	7.19
	mm	94	94	94	116	161	161	161	183
F	THREAD SIZE	1/4" NPT	3/8" NPT	1/2" NPT	3/4" NPT	1" NPT	1-1/4" NPT	1-1/2" NPT	2" NPT
Cv		7	7	13	30	61	110	185	360

Note: DN (Diameter Nominal) = Metric equivalent size.

The information presented on this sheet is correct at the time of publication. Milwaukee Valve reserves the right to change design, and/or material specifications without notice. For the Installation, Operation and Maintenance Manual (IOM) see the Technical/Service Information section on our website. For the most current information access [www.milwaukeevalve.com](http://www.milwaukeevalve.com)



# BA-400/400S\* P2 1/2"-2"



**Bronze Ball Valve**  
**Two Piece**  
**Full Port**  
**250 psig @ 250°F†**  
**Press x Press Ends**  
**Blow-Out Proof Stem**  
**MSS SP-110**

\*Not intended for use in potable water.

## MATERIAL LIST

ITEM	PART	MATERIAL	ASTM SPEC
1	Body	Cast Bronze	B584
2	Tailpiece	Brass	B283
		Cast Bronze (1 1/4" & up)	B584
3	Ball	Brass w/Hard Chrome Plating	B16
		316 Stainless Steel (BA-400S)	A276
4	Seat	RPTFE, 15% Glass Filled	
5	Stem	Brass	B16
		316 Stainless Steel (BA-400S)	A276
6	Thrust Washer	RPTFE, 25% Glass Filled	
7	Packing	PTFE	
8	Packing Nut	Brass	B16
9	Handle	Steel w/Zinc Plating	Commercial
10	Hand Grip	Vinyl	
11	Handle Nut	Steel w/Zinc Plating	Commercial
12	Press Adapters	Brass Fitting w/EPDM O-Ring	B283

(1) Ball & Stem are stainless steel for BA-400S P2

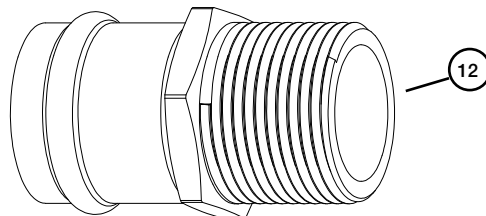

Press End Adapter (4151 Series)

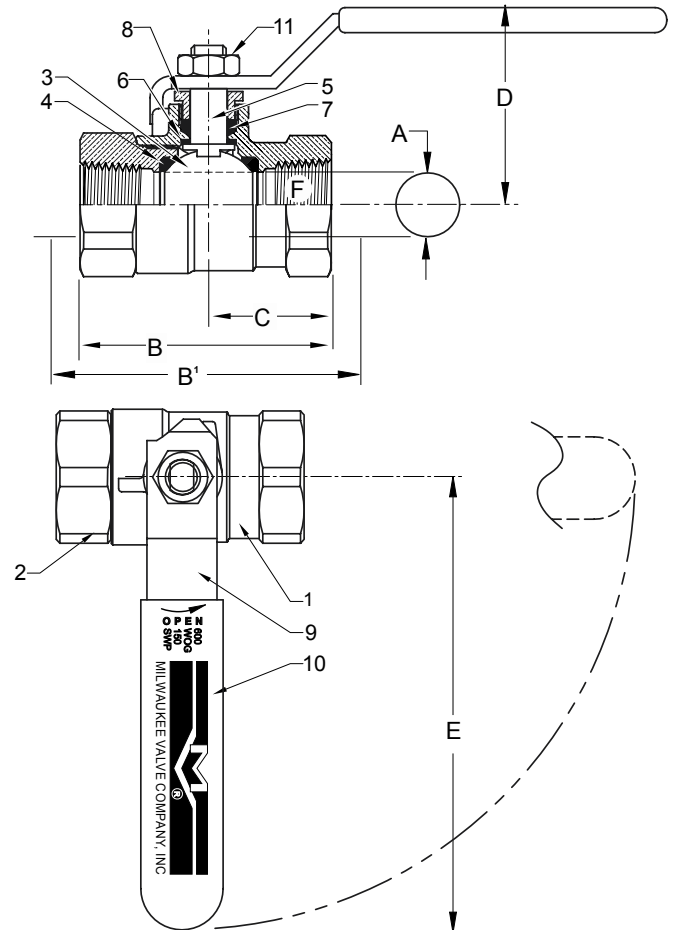

## DIMENSIONS

	UNITS	1/2" DN15	3/4" DN20	1" DN25	1-1/4" DN32	1-1/2" DN40	2" DN50
	A (DIA)	INCHES	1.91	2.32	2.68	2.82	3.00
	mm	47	59	68	72	76	85
STD INSERTION DEPTH	INCHES	3.82	4.55	6.33	6.33	6.33	7.19
	mm	94	116	161	161	161	183
B	INCHES	1/2" NPT	3/4" NPT	1" NPT	1-1/4" NPT	1-1/2" NPT	2" NPT
	mm	132	157	186	199	228	282
C	INCHES	1.10	1.30	1.59	1.81	2.06	2.37
	mm	27	33	40	46	52	60
D	INCHES	1.91	2.32	2.68	2.82	3.00	3.36
	mm	47	59	68	72	76	85
E	INCHES	3.82	4.55	6.33	6.33	6.33	7.19
	mm	94	116	161	161	161	183
F	THREAD SIZE	1/2" NPT	3/4" NPT	1" NPT	1-1/4" NPT	1-1/2" NPT	2" NPT

+NON-SHOCK

Note: DN (Diameter Nominal) = Metric equivalent size.

The information presented on this sheet is correct at the time of publication. Milwaukee Valve reserves the right to change design, and/or material specifications without notice. For the Installation, Operation and Maintenance Manual (IOM) see the Technical/Service Information section on our website. For the most current information access [www.milwaukeevalve.com](http://www.milwaukeevalve.com)



# BA-400S3\* 1/2"-2"

**Bronze Ball Valve  
Two Piece  
Full Port  
600 WOG/250 SWP  
Threaded Ends  
Blow-Out Proof Stem  
MSS SP-110**

**\*Not intended for use in potable water.**

## MATERIALS LIST

ITEM	PART	MATERIALS	ASTM SPEC.
1	Body	Cast Bronze	B584
2	Tailpiece	Brass	B283
		Cast Bronze (1 1/4" & up)	B584
3	Ball	316 Stainless Steel	A276
4	Seat	Multi-Fill PTFE	
5	Stem	Brass	B16
		316 Stainless Steel	A276
6	Thrust Washer	Multi-Fill PTFE	
7	Packing	PTFE	
8	Packing Nut	Brass	B16
9	Handle	Steel w/Zinc Plating	Commercial
10	Hand Grip	Vinyl	Commercial
11	Handle Nut	Steel w/Zinc Plating	Commercial

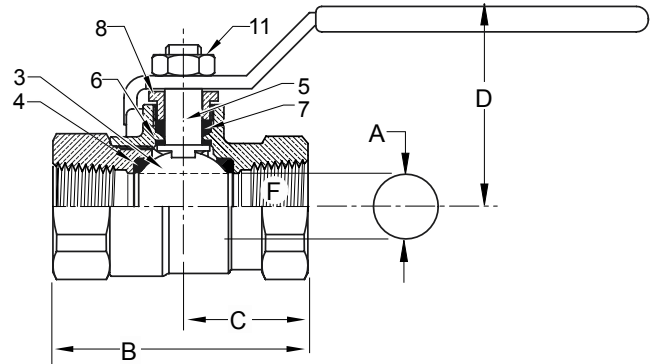

## PRESSURE/TEMPERATURE RATINGS

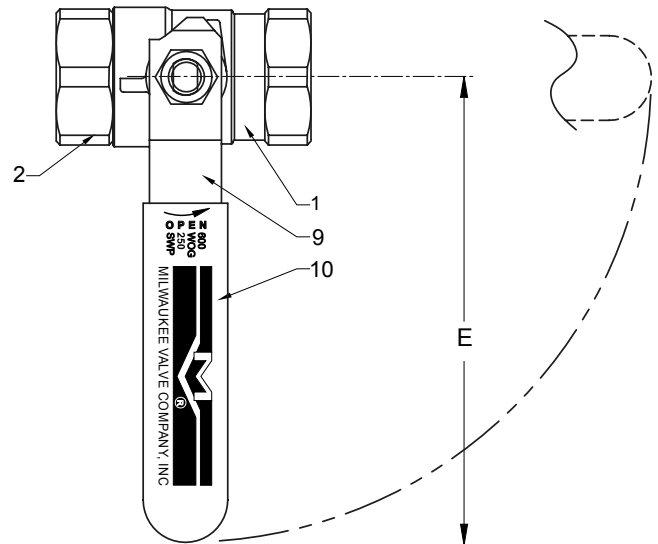
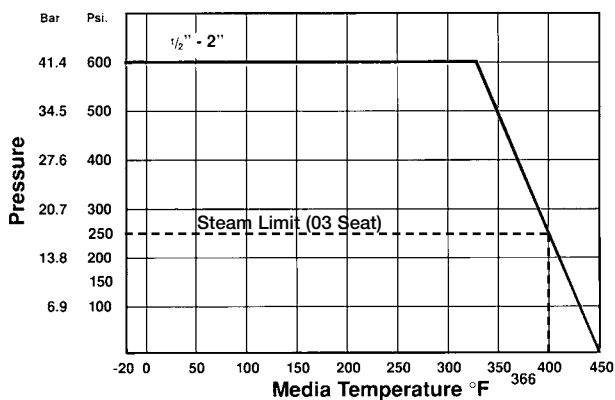

## DIMENSIONS

	UNITS	1/2" DN15	3/4" DN20	1" DM25	1-1/4" DM32	1-1/2" DN40	2" DN50
A (DIA)	INCHES	0.50	0.76	1.06	1.31	1.56	2.00
	mm	13	19	27	33	40	51
B	INCHES	2.19	2.59	3.32	3.77	4.28	5.10
	mm	54	66	84	96	109	130
C	INCHES	1.10	1.30	1.59	1.81	2.06	2.37
	mm	27	33	40	46	52	60
D	INCHES	1.91	2.32	2.68	2.82	3.00	3.36
	mm	47	59	68	72	76	85
E	INCHES	3.82	4.55	6.33	6.33	6.33	7.19
	mm	94	116	161	161	161	183
F	THREAD SIZE	1/2" NPT	3/4" NPT	1" NPT	1-1/4" NPT	1-1/2" NPT	2" NPT
Cv		13	30	61	110	185	360

Note: DN (Diameter Nominal) = Metric equivalent size.

The information presented on this sheet is correct at the time of publication. Milwaukee Valve reserves the right to change design, and/or material specifications without notice. For the Installation, Operation and Maintenance Manual (IOM) see the Technical/Service Information section on our website. For the most current information access [www.milwaukeevalve.com](http://www.milwaukeevalve.com)



# BA-450/450S\* 3/8"-2"

**Bronze Ball Valve  
Two Piece  
Full Port  
600 WOG  
Solder Ends  
Blow-Out Proof Stem  
MSS SP-110**

\*Not intended for use in potable water.

## MATERIALS LIST

ITEM	PART	MATERIALS	ASTM SPEC.
1	Body	Cast Bronze	B584
2	Tailpiece	Brass	B283
		Cast Bronze (1 1/4" & up)	B584
3	Ball	Brass w/Hard Chrome Plating	B16
		316 Stainless Steel (1)	A276
4	Seat	RPTFE, 15% Glass Filled	
5	Stem	Brass	B16
		316 Stainless Steel (1)	A276
6	Thrust Washer	RPTFE, 25% Glass Filled	
7	Packing	PTFE	
8	Packing Nut	Brass	B16
9	Handle	Steel w/Zinc Plating	Commercial
10	Hand Grip	Vinyl	Commercial
11	Handle Nut	Steel w/Zinc Plating	Commercial

(1) Ball and stem are stainless for 450S.

## PRESSURE - TEMPERATURE DATA VALVES RATED FOR VACUUM SERVICE TO 29 INCHES Hg.

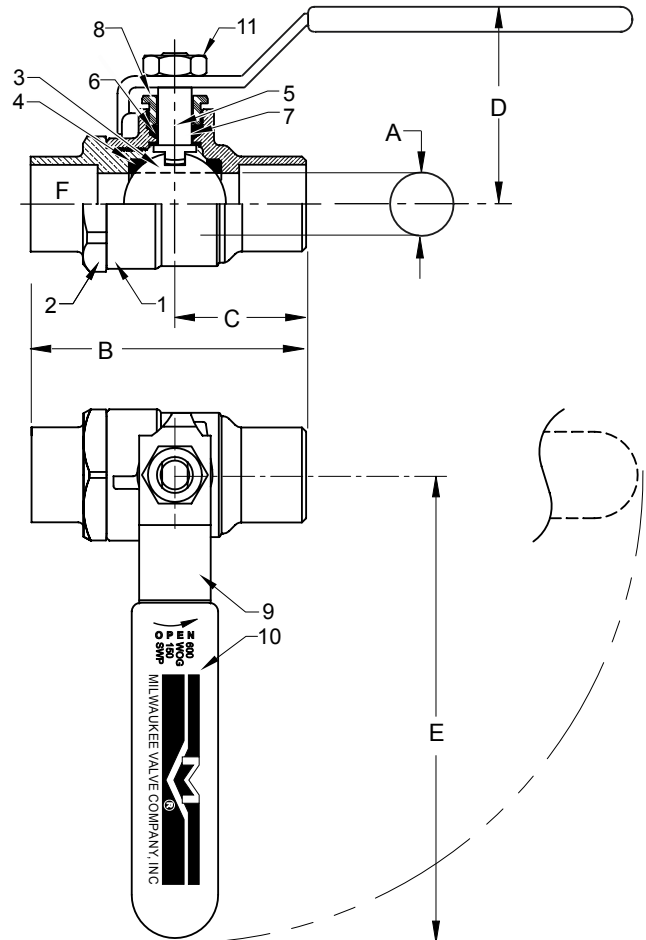
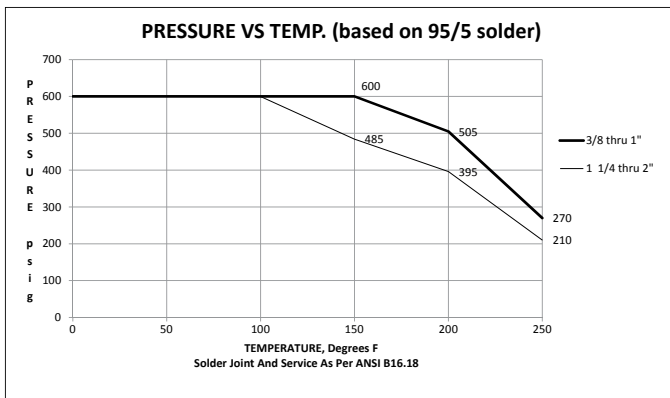

## DIMENSIONS

	UNITS	3/8" DN10	1/2" DN15	3/4" DN20	1" DM25	1-1/4" DM32	1-1/2" DN40	2" DN50
A (DIA)	INCHES	0.38	0.50	0.76	1.06	1.31	1.56	2.00
	mm	10	13	19	27	32	40	51
B	INCHES	2.05	2.39	3.17	3.75	5.00	6.00	6.75
	mm	52	59	81	95	127	152	172
C	INCHES	0.91	1.07	1.50	1.79	2.49	3.00	3.37
	mm	23	27	38	46	63	76	86
D	INCHES	1.80	1.87	2.19	2.67	2.82	2.99	3.51
	mm	44	46	56	68	72	76	89
E	INCHES	3.80	3.80	4.56	6.31	6.31	6.31	7.19
	mm	97	97	116	160	160	160	183
F	TUBE SIZE Ø	0.51	0.63	0.88	1.13	1.38	1.63	2.13
	Cv	7	15	35	60	110	185	360

Note: DN (Diameter Nominal) = Metric equivalent size.

The information presented on this sheet is correct at the time of publication. Milwaukee Valve reserves the right to change design, and/or material specifications without notice. For the Installation, Operation and Maintenance Manual (IOM) see the Technical/Service Information section on our website. For the most current information access [www.milwaukeevalve.com](http://www.milwaukeevalve.com)



# “BA-475B”\* 1/4”-4”



1/4” through 2” Only

**Brass Ball Valve**  
**Two Piece**  
**Full Port**  
**600 WOG (1/4” - 3”) 400 WOG (4”)**  
**Threaded Ends**  
**Blow-Out Proof Stem**  
**MSS SP-110, ASME A112.4.14**

\*Not intended for use in potable water.

## MATERIALS LIST

ITEM	PART	MATERIALS	ASTM SPEC.
1	Body	Brass, Forged	B283
2	Tailpiece	Brass, Forged	B283
3	Ball	CP Brass (3/8" - 1 1/4")	B283
		CP Brass, Cast (1 1/2" - 4")	B584
4	Ball Seal	PTFE	Commercial
5	Stem	Brass	B124
6	O-Ring	Buna-N	D2006
7	Thrust Washer	PTFE	Commercial
8	Gland Nut	Brass	B16
9	Packing	PTFE	Commercial
10	Handle	Zinc Plated Steel	Commercial
11	Hand Grip	Zinc Plated Steel	Commercial
****12	Body Seal	PTFE	Commercial

\*Also Available BA-475B-LL

(Locks only in closed position)

\*\* Not Suitable For Ammonia Service

\*\*\*Not intended for use in potable water.

\*\*\*\*4” Valve Only

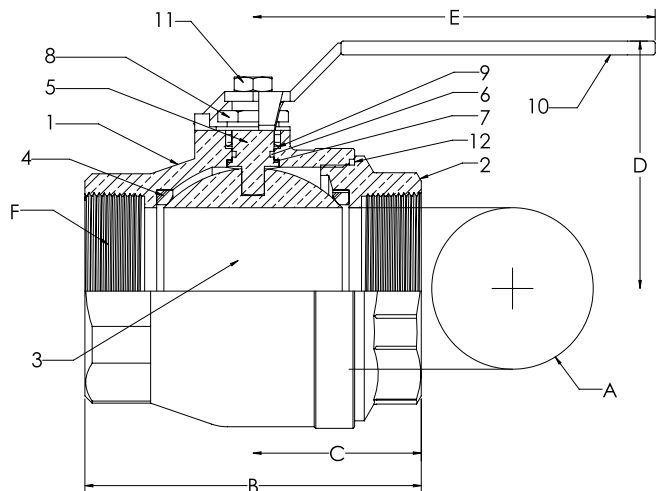
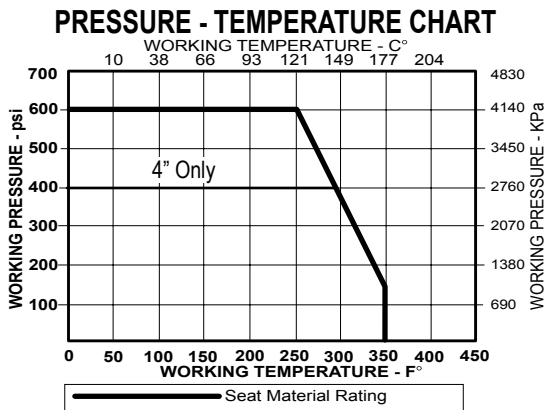

## DIMENSIONS

	UNITS	1/4”	3/8”	1/2”	3/4”	1”	1-1/4”	1-1/2”	2”	2-1/2”	3”	4”
	A (DIA)	INCHES	0.39	0.39	0.51	0.76	1.00	1.26	1.50	2.00	2.48	2.95
	mm	10	10	13	19	25	32	38	51	63	75	100
B	INCHES	1.87	1.87	2.25	2.62	3.06	3.50	3.75	4.38	5.16	6.00	8.20
	mm	47	47	57	67	78	89	95	111	131	152	208
C	INCHES	0.95	0.95	1.12	1.31	1.91	2.21	1.87	2.19	2.58	3.00	4.11
	mm	24	24	28	33	49	56	47	56	66	76	104
D	INCHES	1.42	1.42	1.46	1.93	2.10	2.33	2.52	2.96	3.94	4.37	5.93
	mm	36	36	37	49	53	59	64	75	100	111	151
E	INCHES	3.14	3.14	3.14	4.35	4.35	5.00	5.00	6.90	7.87	7.87	9.65
	mm	80	80	80	110	110	127	127	175	200	200	245
F	THREAD SIZE	1/4” NPT	3/8” NPT	1/2” NPT	3/4” NPT	1” NPT	1-1/4” NPT	1-1/2” NPT	2” NPT	2-2/1” NPT	3” NPT	4” NPT
	Cv	12	12	18	40	72	112	161	287	307	323	584

The information presented on this sheet is correct at the time of publication. Milwaukee Valve reserves the right to change design, and/or material specifications without notice. For the Installation, Operation and Maintenance Manual (IOM) see the Technical/Service Information section on our website. For the most current information access [www.milwaukeevalve.com](http://www.milwaukeevalve.com)





# "BA-485B"\* 1/2"-4"

**Brass Ball Valve**  
**Two Piece**  
**Full Port**  
**600 WOG (1/4" - 3") 400 WOG (4")**  
**Solder Ends**  
**Blow-Out Proof Stem**  
**MSS SP-110, ASME A112.4.14**

\*Not intended for use in potable water.  
 \*\*4" Valve Only

## MATERIALS LIST

ITEM	PART	MATERIALS	ASTM SPEC.
1	Body	Brass, Forged	B283
2	Tailpiece	Brass, Forged	B283
3	Ball	CP Brass (1/2" - 1 1/4")	B283
		CP Brass, Cast (1 1/2" - 4")	B584
4	Ball Seal	PTFE	Commercial
5	Stem	Brass	B124
6	O-Ring	Buna-N	D2006
7	Thrust Washer	PTFE	Commercial
8	Gland Nut	Brass	B16
9	Packing	PTFE	Commercial
10	Handle	Zinc Plated Steel	Commercial
11	Hand Grip	Zinc Plated Steel	Commercial
**12	Body Seal	PTFE	Commercial

## PRESSURE - TEMPERATURE CHART

VACUUM SERVICE TO 29 INCHES Hg.

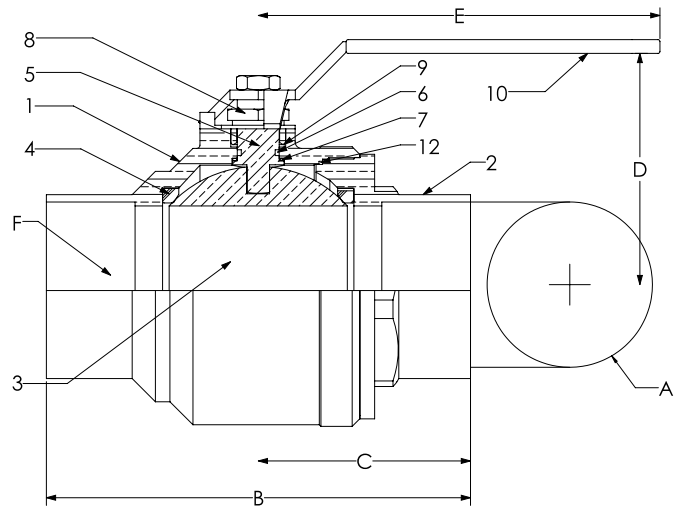
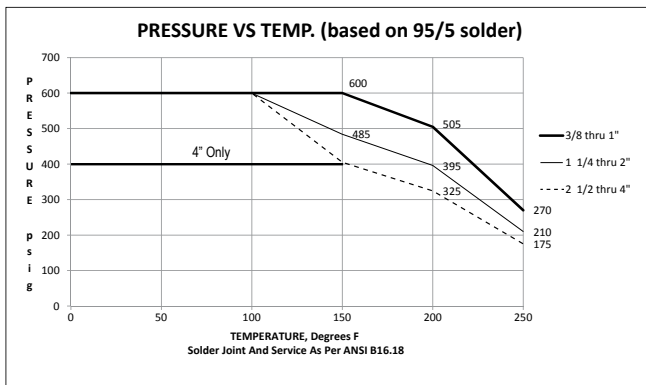

## DIMENSIONS

	UNITS	1/2"	3/4"	1"	1-1/4"	1-1/2"	2"	2-1/2"	3"	4"
A	INCHES	0.50	0.76	1.00	1.26	1.50	2.00	2.48	2.95	3.94
	mm	13	19	25	32	38	51	63	75	100
B	INCHES	2.28	3.10	3.56	4.13	4.64	5.75	7.25	8.25	10.33
	mm	58	79	90	105	118	146	184	210	262
C	INCHES	1.14	1.55	1.78	2.06	2.32	2.87	3.62	4.12	5.17
	mm	29	39	45	52	59	73	92	105	131
D	INCHES	1.46	1.93	2.10	2.33	2.52	2.96	3.94	4.37	5.96
	mm	37	49	53	59	64	75	100	111	151
E	INCHES	3.14	4.35	4.53	5.00	5.00	6.90	7.87	7.87	9.65
	mm	80	110	110	127	127	175	200	200	245
F	TUBE SIZE	0.63	0.88	1.13	1.38	1.63	2.13	2.63	3.13	4.13
Cv		18	40	72	112	161	287	307	323	584

The information presented on this sheet is correct at the time of publication. Milwaukee Valve reserves the right to change design, and/or material specifications without notice. For the Installation, Operation and Maintenance Manual (IOM) see the Technical/Service Information section on our website. For the most current information access [www.milwaukeevalve.com](http://www.milwaukeevalve.com)





# BA-500/BA-550\* 3/4"-1 1/4"

**Brass Flange Ball Valve**  
**Two Piece**  
**Full Port**  
**600 WOG /150 WOG**  
**BA-500 Threaded Ends/ BA-550 Solder Ends**  
**Sold In Packages of 2**  
**Kit Includes 4 Bolts & Nuts, Plus T-Handle (1)**  
**Blow-Out Proof Stem**  
**MSS SP-110, ASME A112.4.14**

\*Not intended for use in potable water.

## MATERIALS LIST

ITEM	PART	MATERIALS	ASTM SPEC.
1	Body	Brass, Forged	B283
2	Tailpiece	Brass, Forged	B283
3	Ball	Brass with Nickel chrome Plating	B283
4	Ball Seal	PTFE	Comercial
5	Stem	Brass	B124
6	O-Ring	Buna-N	D2006
7	Thrust Washer	PTFE	Commercial
8	Gland Nut	Brass	B124
9	Packing	PTFE	Commercial
10	Handle	Zinc Plated Steel	Commercial
11	Hand Grip	Zinc Plated Steel	Commercial

## PRESSURE - TEMPERATURE CHART

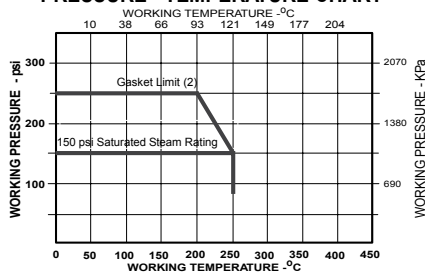

## DIMENSIONS

	UNITS	3/4" DN20	1" DN25	1-1/4" DN32
A O.V.L./THD	INCHES	2.50	2.81	2.99
	mm	64	71	76
A O.V.L./SWT	INCHES	2.69	3.13	3.38
	mm	68	80	86
B	INCHES	1.24	1.32	1.32
	mm	31	34	34
C	INCHES	1.95	2.12	2.31
	mm	50	54	59
D	INCHES	3.29	3.29	3.29
	mm	84	84	84
E PORT DIA.	INCHES	0.75	1.00	1.25
	mm	19	25	32
F FLANGE DIA.	INCHES	4.33	4.33	4.33
	mm	110	110	110
G	INCHES	4.72	4.72	4.72
	mm	120	120	120
H MTG. HOLE	INCHES	0.51	0.51	0.51
	mm	13	13	13
J	INCHES	2.67	2.67	2.67
	mm	68	68	68
K	INCHES	0.28	0.28	0.28
	mm	7	7	7
L	INCHES	0.14	0.14	0.14
	mm	4	4	4

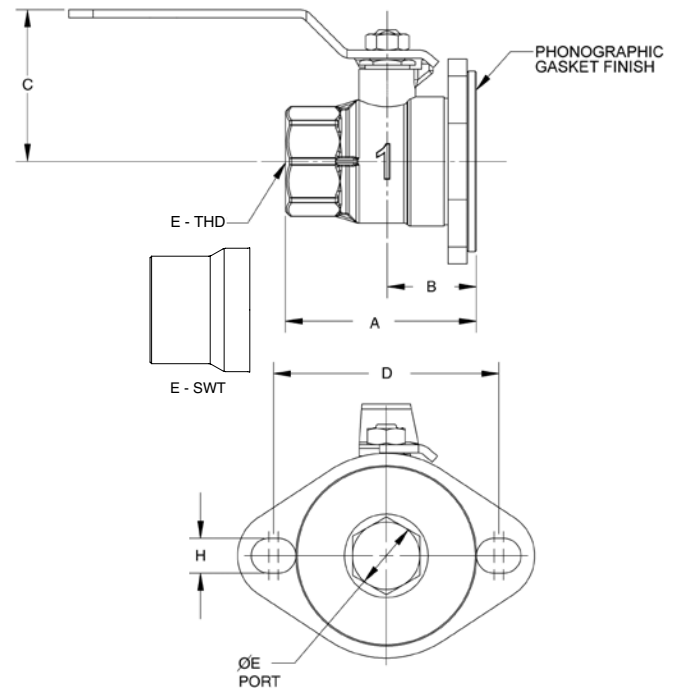
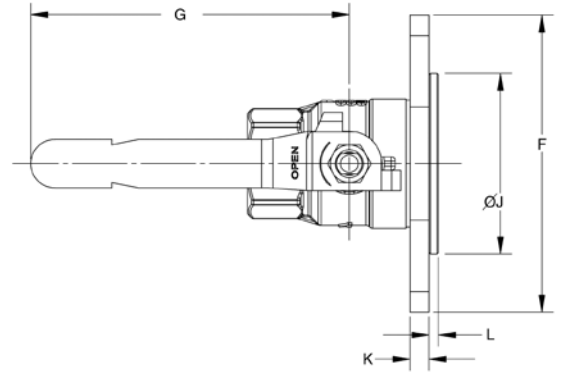

The information presented on this sheet is correct at the time of publication. Milwaukee Valve reserves the right to change design, and/or material specifications without notice. For the Installation, Operation and Maintenance Manual (IOM) see the Technical/Service Information section on our website. For the most current information access [www.milwaukeevalve.com](http://www.milwaukeevalve.com)



# BA-480B\* 1/2"-3"



**Brass Ball Valve  
Two Piece  
Full Port  
250 psig @ 250°F†  
Press x Press Ends  
Blow-Out Proof Stem**

\*Not intended for use in potable water.

## MATERIALS LIST

ITEM	PART	MATERIALS	ASTM SPEC.
1	Body	Brass, Forged	B283
2	Tailpiece	Brass, Forged	B283
3	Ball	CP Brass Ball	B283
4	Ball Seat	PTFE	Commercial
5	Stem	Brass	B124
6	Stem O-Ring	Buna-N	
7	Thrust Washer	PTFE	Commercial
8	Gland Nut	Brass	B124
9	Packing	PTFE	Commercial
10	Handle	Steel w/Zinc Plating	Commercial
11	Handle Nut	Steel w/Zinc Plating	Commercial
12	Tube O-Ring	Plastic	Commercial
13**	Backing Ring	EPDM	Commercial
14**	Gripping Ring	Stainless Steel	Commercial

\*Ultra Press Valves are designed and qualified for use in copper tubing systems only, Types K, L, & M per ASTM B88.

\*\*For Installation Instructions please see engineering section on website.

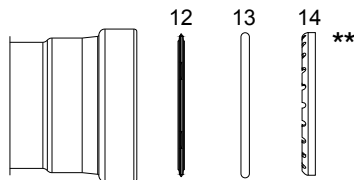

\*\* 2 1/2" & 3" Requires XLC installation jaws.

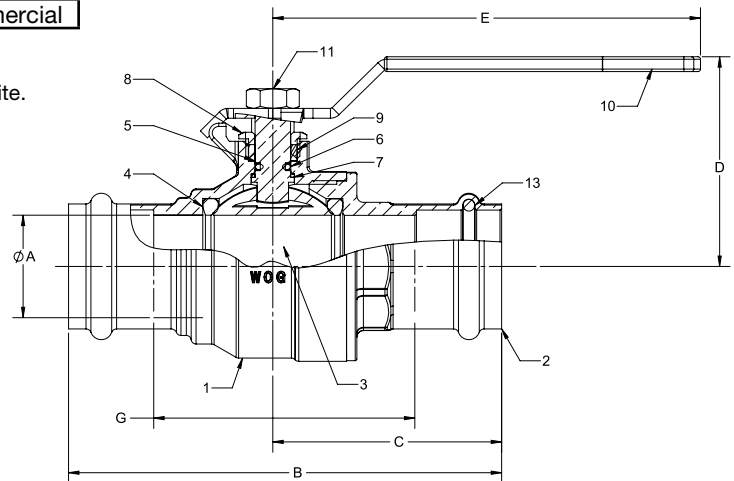

## DIMENSIONS

	UNITS	1/2" DN15	3/4" DN20	1" DN25	1-1/4" DN32	1-1/2" DN40	2" DN50	2-1/2" DN65	3" DN80
A	INCHES	0.51	0.76	0.98	1.26	1.50	2.01	2.48	2.95
	mm	13	19	25	32	38	51	63	75
B	INCHES	3.16	3.71	4.28	5.20	6.31	7.44	11.92	14.07
	mm	80	94	109	132	160	189	303	357
C	INCHES	1.63	1.92	2.18	2.75	3.40	3.96	5.96	7.04
	mm	41	49	55	70	86	101	151	179
D	INCHES	1.62	2.01	2.21	2.46	2.62	3.13	3.94	4.12
	mm	41	51	56	63	67	80	100	111
E	INCHES	3.15	4.33	4.33	5.12	5.12	6.89	7.87	7.87
	mm	80	110	110	130	130	175	200	200
G	INCHES	1.52	1.73	2.31	3.16	3.49	4.28	8.17	9.86
	mm	39	44	59	80	89	109	208	250
Cv		18	40	72	112	161	287	448	645

The information presented on this sheet is correct at the time of publication. Milwaukee Valve reserves the right to change design, and/or material specifications without notice. For the Installation, Operation and Maintenance Manual (IOM) see the Technical/Service Information section on our website. For the most current information access [www.milwaukeevalve.com](http://www.milwaukeevalve.com)



# BA-480S\* 1/2"-2"



Brass Ball Valve  
Two Piece  
Full Port  
250 psig @ 250°F†  
Press x Press Ends  
Blow-Out Proof Stem

\*Not intended for use in potable water.

## MATERIALS LIST

ITEM	PART	MATERIALS	ASTM SPEC.
1	Body	Brass, Forged	B283
2	Tailpiece	Brass, Forged	B283
3	Ball	316 S.S.	A276
4	Ball Seat	PTFE	Commercial
5	Stem	316 S.S.	A276
6	Stem O-Ring	Buna-N	Commercial
7	Thrust Washer	PTFE	Commercial
8	Gland Nut	Brass	B124
9	Packing	PTFE	Commercial
10	Handle	Steel w/Zinc Plating	Commercial
11	Handle Nut	Steel w/Zinc Plating	Commercial

\*Ultra Press Valves are designed and qualified for use in copper tubing systems only, Types K, L, & M per ASTM B88.

\*\*For Installation Instructions please see engineering section on website.

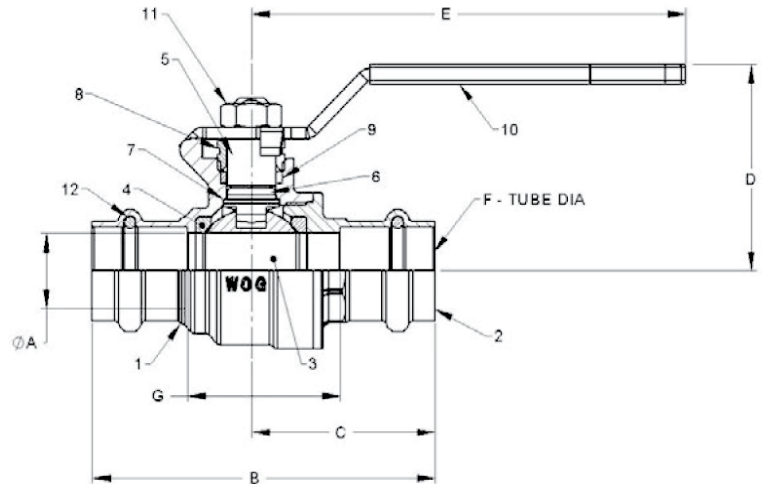

## DIMENSIONS

	UNITS	1/2" DN15	3/4" DN20	1" DN25	1-1/4" DN32	1-1/2" DN40	2" DN50
	A	INCHES	0.51	0.76	0.98	1.26	1.50
	mm	13	19	25	32	38	51
B	INCHES	3.16	3.71	4.28	5.20	6.31	7.44
	mm	80	94	109	132	160	189
C	INCHES	1.63	1.92	2.18	2.75	3.40	3.96
	mm	41	49	55	70	86	101
D	INCHES	1.62	2.01	2.21	2.46	2.62	3.13
	mm	41	51	56	63	67	80
E	INCHES	3.15	4.33	4.33	5.12	5.12	6.89
	mm	80	110	110	130	130	175
G	INCHES	1.52	1.73	2.31	3.16	3.49	4.28
	mm	39	44	59	80	89	109
Cv		18	40	72	112	161	287

The information presented on this sheet is correct at the time of publication. Milwaukee Valve reserves the right to change design, and/or material specifications without notice. For the Installation, Operation and Maintenance Manual (IOM) see the Technical/Service Information section on our website. For the most current information access [www.milwaukeevalve.com](http://www.milwaukeevalve.com)



# BA-480BH\* 1/2"-3/4"



Brass Ball Valve  
Two Piece  
Full Port  
250 psig @ 250°F†  
Press x Hose Ends  
Blow-Out Proof Stem

\*Not intended for use in potable water.

## MATERIALS LIST

ITEM	PART	MATERIALS	ASTM SPEC.
1	Body	Brass, Forged	B283
2	Tailpiece	Brass, Forged	B283
3	Ball	CP Brass Ball	B283
4	Ball Seat	PTFE	Commercial
5	Stem	Brass	B124
6	Stem O-Ring	Buna-N	
7	Thrust Washer	PTFE	Commercial
8	Gland Nut	Brass	B124
9	Packing	PTFE	Commercial
10	Handle	Steel w/Zinc Plating	Commercial
11	Handle Nut	Steel w/Zinc Plating	Commercial
12	Tube O-Ring	Plastic	Commercial
13	Hose Cap	Polypropylene	
14	Cap Gasket	EPDM	
15	Chain	Brass Bead	

\*Ultra Press Valves are designed and qualified for use in copper tubing systems only, Types K, L, & M per ASTM B88.

## DIMENSIONS

	UNITS	1/2" DN15	3/4" DN20
A	INCHES	0.51	0.76
	mm	13	19
B	INCHES	3.06	3.50
	mm	78	90
C	INCHES	1.41	1.66
	mm	36	42
D	INCHES	1.62	2.01
	mm	41	51
E	INCHES	3.15	4.33
	mm	80	110
F-TUBE DIA	INCHES	0.82	0.99
	mm	21	25
Cv		18	40

NOTE: Pressure / Temperature ratings shown are for valve only. Hose side pressure and temperature limit is based on connected hose and is the users responsibility.

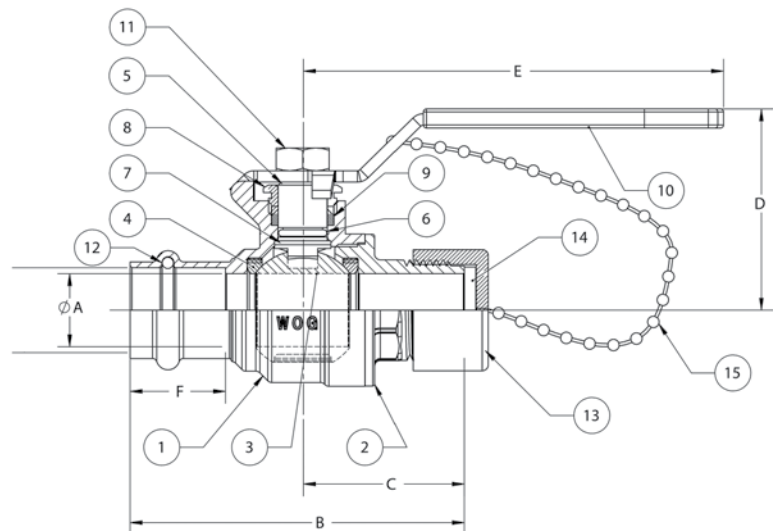

**Do not pressurize cap.  
Pressure not to exceed 40 psi.**

The information presented on this sheet is correct at the time of publication. Milwaukee Valve reserves the right to change design, and/or material specifications without notice. For the Installation, Operation and Maintenance Manual (IOM) see the Technical/Service Information section on our website. For the most current information access [www.milwaukeevalve.com](http://www.milwaukeevalve.com)



# BA-480SH\* 1/2"-3/4"



Brass Ball Valve  
Two Piece  
Full Port  
250 psig @ 250°F†  
Press x Hose Ends  
Blow-Out Proof Stem

\*Not intended for use in potable water.

## MATERIALS LIST

ITEM	PART	MATERIALS	ASTM SPEC.
1	Body	Brass, Forged	B283
2	Tailpiece	Brass, Forged	B283
3	Ball	316 S.S.	A276
4	Ball Seat	PTFE	Commercial
5	Stem	316 S.S.	A276
6	Stem O-Ring	Buna-N	
7	Thrust Washer	PTFE	Commercial
8	Gland Nut	Brass	B124
9	Packing	PTFE	Commercial
10	Handle	Steel w/Zinc Plating	Commercial
11	Handle Nut	Steel w/Zinc Plating	Commercial
12	Tube O-Ring	Plastic	Commercial
13	Hose Cap	Polypropylene	
14	Cap Gasket	EPDM	
15	Chain	Brass Bead	

\*Ultra Press Valves are designed and qualified for use in copper tubing systems only, Types K, L, & M per ASTM B88.

## DIMENSIONS

	UNITS	1/2" DN15	3/4" DN20
A-PORT DIA	INCHES	0.51	0.76
	mm	13	19
B	INCHES	3.06	3.50
	mm	78	90
C	INCHES	1.41	1.66
	mm	36	42
D	INCHES	1.62	2.01
	mm	41	51
E	INCHES	3.15	4.33
	mm	80	110
F-TUBE DIA	INCHES	0.82	0.99
	mm	21	25
Cv		18	40

NOTE: Pressure / Temperature ratings shown are for valve only. Hose side pressure and temperature limit is based on connected hose and is the users responsibility.

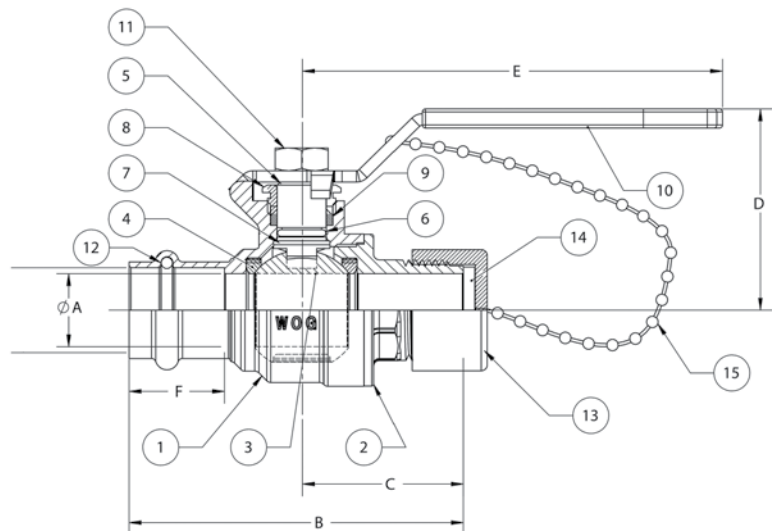

**Do not pressurize cap.  
Pressure not to exceed 40 psi.**

The information presented on this sheet is correct at the time of publication. Milwaukee Valve reserves the right to change design, and/or material specifications without notice. For the Installation, Operation and Maintenance Manual (IOM) see the Technical/Service Information section on our website. For the most current information access [www.milwaukeevalve.com](http://www.milwaukeevalve.com)



# BA-481B\* 1/2"-3"



Brass Ball Valve

Two Piece

Full Port

250 psig @ 250°F†

Press x Press Ends

With Extension Stem & Memory Stop

Blow-Out Proof Stem

\*Not intended for use in potable water.

## MATERIALS LIST

ITEM	PART	MATERIALS	ASTM SPEC.
1	Body	Brass, Forged	B283
2	Tailpiece	Brass, Forged	B283
3	Ball	CP Brass Ball	B283
4	Ball Seat	PTFE	Commercial
5	Stem	Brass	B124
6	Stem O-Ring	Buna-N	
7	Thrust Washer	PTFE	Commercial
8	Gland Nut	Brass	B124
9	Packing	PTFE	Commercial
10	Handle	Steel w/Zinc Plating	B633
11	Handle Bolt	Steel w/Zinc Plating	Commercial
12	Tube O-Ring	EPDM	D2000 NSF61
13	Stem Stop Plate	Steel w/Zinc Plating	Commercial
14	Internal Extension Tube	Steel w/Zinc Plating	Commercial
15	External Extension Tube	Steel w/Zinc Plating	Commercial
16	Upper Stem Adaptor	Steel w/Zinc Plating	Commercial
17	Memory Stop	Steel w/Zinc Plating	Commercial

\*Ultra Press Valves are designed and qualified for use in copper tubing systems only, Types K & L per ASTM B88.

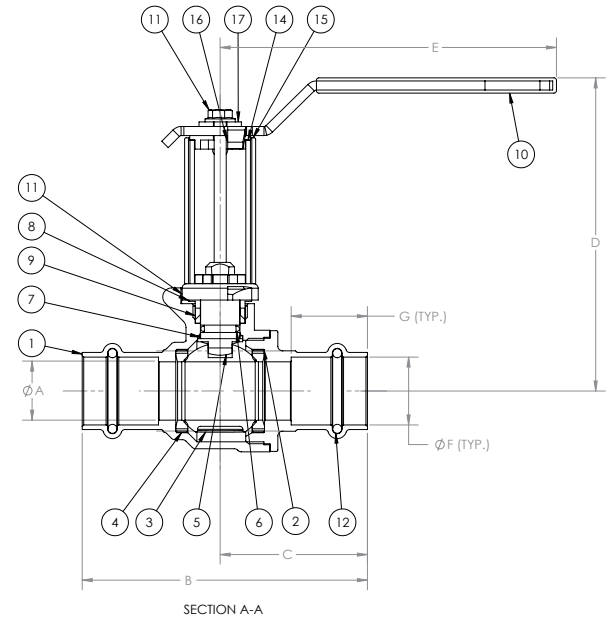

## DIMENSIONS

	UNITS	1/2"	3/4"	1"	1-1/4"	1-1/2"	2"	2-1/2"	3"
		DN15	DN20	DN25	DN32	DN40	DN50	DN65	DN80
A-PORT DIA	INCHES	0.51	0.76	0.98	1.26	1.50	2.01	2.48	2.95
	mm	13	19	25	32	38	51	63	75
B	INCHES	3.16	3.71	4.28	5.20	6.31	7.44	11.92	14.07
	mm	80	94	109	132	160	189	303	357
C	INCHES	1.63	1.92	2.18	2.75	3.40	3.96	5.96	7.04
	mm	41	49	55	70	86	101	151	179
D	INCHES	3.87	4.26	4.46	4.71	4.87	5.38	6.19	6.37
	mm	98	108	113	120	124	137	157	162
E	INCHES	3.15	4.33	4.33	5.12	5.12	6.89	7.87	7.87
	mm	80	110	110	130	130	175	200	200
G	INCHES	1.52	1.73	2.31	3.16	3.49	4.28	8.17	9.86
	mm	39	44	59	80	89	109	208	250
Cv		18	40	72	112	161	287	448	645

The information presented on this sheet is correct at the time of publication. Milwaukee Valve reserves the right to change design, and/or material specifications without notice. For the Installation, Operation and Maintenance Manual (IOM) see the Technical/Service Information section on our website. For the most current information access [www.milwaukeevalve.com](http://www.milwaukeevalve.com)



# BA-481S\* 1/2"-2"



**Brass Ball Valve**  
**Two Piece**  
**Full Port**  
**250 psig @ 250°F†**  
**Press x Press Ends**  
**With Extension Stem & Memory Stop**  
**Blow-Out Proof Stem**

\*Not intended for use in potable water.

## MATERIALS LIST

ITEM	PART	MATERIALS	ASTM SPEC.
1	Body	Brass, Forged	B283
2	Tailpiece	Brass, Forged	B283
3	Ball	316 S.S.	A276
4	Ball Seat	PTFE	Commercial
5	Stem	316 S.S.	A276
6	Stem O-Ring	Buna-N	
7	Thrust Washer	PTFE	Commercial
8	Gland Nut	Brass	B124
9	Packing	PTFE	Commercial
10	Handle	Steel w/Zinc Plating	B633
11	Handle Bolt	Steel w/Zinc Plating	Commercial
12	Tube O-Ring	EPDM	D2000 NSF61
13	Stem Stop Plate	Steel w/Zinc Plating	Commercial
14	Internal Extension Tube	Steel w/Zinc Plating	Commercial
15	External Extension Tube	Steel w/Zinc Plating	Commercial
16	Upper Stem Adaptor	Steel w/Zinc Plating	Commercial
17	Memory Stop	Steel w/Zinc Plating	Commercial

†Ultra Press Valves are designed and qualified for use in copper tubing systems only, Types K & L per ASTM B88.

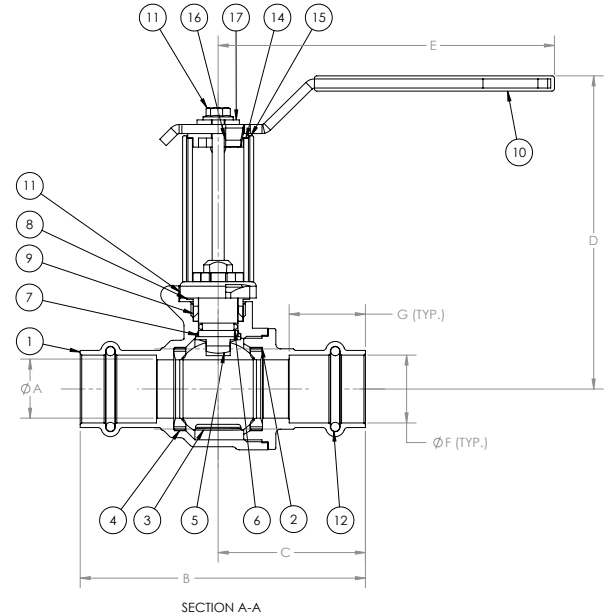

## DIMENSIONS

	UNITS	1/2"	3/4"	1"	1-1/4"	1-1/2"	2"
		DN15	DN20	DN25	DN32	DN40	DN50
A-PORT DIA	INCHES	0.51	0.76	0.98	1.26	1.50	2.01
	mm	13	19	25	32	38	51
B	INCHES	3.16	3.71	4.28	5.20	6.31	7.44
	mm	80	94	109	132	160	189
C	INCHES	1.63	1.92	2.18	2.75	3.40	3.96
	mm	41	49	55	70	86	101
D	INCHES	3.87	4.26	4.46	4.71	4.87	5.38
	mm	98	108	113	120	124	137
E	INCHES	3.15	4.33	4.33	5.12	5.12	6.89
	mm	80	110	110	130	130	175
G	INCHES	1.52	1.73	2.31	3.16	3.49	4.28
	mm	39	44	59	80	89	109
Cv		18	40	72	112	161	287

The information presented on this sheet is correct at the time of publication. Milwaukee Valve reserves the right to change design, and/or material specifications without notice. For the Installation, Operation and Maintenance Manual (IOM) see the Technical/Service Information section on our website. For the most current information access [www.milwaukeevalve.com](http://www.milwaukeevalve.com)



# BA-490B\* 1/2"-2"

## ULTRAPRESS

Brass Ball Valve  
Two Piece  
Full Port  
250 psig @ 250°F†  
Press x Threaded Ends  
Blow-Out Proof Stem

\*Not intended for use in potable water.

### MATERIALS LIST

ITEM	PART	MATERIALS	ASTM SPEC.
1	Body	Brass, Forged	B283
2	Tailpiece	Brass, Forged	B283
3	Ball	CP Brass Ball	B283
4	Ball Seat	PTFE	Commercial
5	Stem	Brass	B124
6	Stem O-Ring	Buna-N	
7	Thrust Washer	PTFE	Commercial
8	Gland Nut	Brass	B124
9	Packing	PTFE	Commercial
10	Handle	Steel w/Zinc Plating	Commercial
11	Handle Bolt	Steel w/Zinc Plating	Commercial
12	Tube O-Ring	Plastic	D2000 NSF61

\*Ultra Press Valves are designed and qualified for use in copper tubing systems only, Types K, L, & M per ASTM B88.

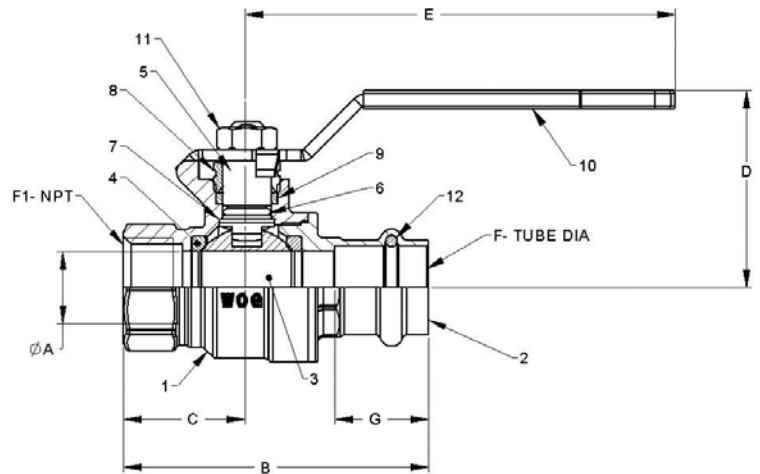

### DIMENSIONS

	UNITS	1/2" DN15	3/4" DN20	1" DN25	1-1/4" DN32	1-1/2" DN40	2" DN50
A-PORT DIA	INCHES	0.51	0.76	0.98	1.26	1.50	2.00
	mm	13	19	25	32	38	51
B	INCHES	2.77	3.23	3.71	4.12	4.86	6.14
	mm	70	82	94	105	123	156
C	INCHES	1.14	1.31	1.53	1.71	1.88	2.19
	mm	29	33	39	43	48	56
D	INCHES	1.46	1.93	2.10	2.33	2.52	2.96
	mm	37	49	53	59	64	75
E	INCHES	3.14	4.35	4.35	5.00	5.00	6.90
	mm	80	110	110	127	127	175
F-TUBE DIA	INCHES	0.63	0.88	1.13	1.38	1.63	2.13
	mm	15	20	25	32	40	50
F1 NPT	INCHES	1/2"-14	3/4"-14	1"-11.5	1-1/4"-11.5	1-1/2"-11.5	2"-11.5
G	INCHES	0.83	1.00	1.00	1.02	1.42	1.57
	mm	21	25	25	26	36	40
Cv		18	40	72	112	161	287

The information presented on this sheet is correct at the time of publication. Milwaukee Valve reserves the right to change design, and/or material specifications without notice. For the Installation, Operation and Maintenance Manual (IOM) see the Technical/Service Information section on our website. For the most current information access [www.milwaukeevalve.com](http://www.milwaukeevalve.com)





# BA-490S\* 1/2"-2"

## ULTRAPRESS

Brass Ball Valve  
Two Piece  
Full Port  
250 psig @ 250°F†  
Press x Threaded Ends  
Blow-Out Proof Stem

\*Not intended for use in potable water.

### MATERIALS LIST

ITEM	PART	MATERIALS	ASTM SPEC.
1	Body	Brass, Forged	B283
2	Tailpiece	Brass, Forged	B283
3	Ball	316 S.S.	A276
4	Ball Seat	PTFE	Commercial
5	Stem	316 S.S.	A276
6	Stem O-Ring	Buna-N	
7	Thrust Washer	PTFE	Commercial
8	Gland Nut	Brass	B124
9	Packing	PTFE	Commercial
10	Handle	Steel w/Zinc Plating	Commercial
11	Handle Bolt	Steel w/Zinc Plating	Commercial
12	Tube O-Ring	EPDM	D2000 NSF61

\*Ultra Press Valves are designed and qualified for use in copper tubing systems only, Types K, L, & M per ASTM B88.

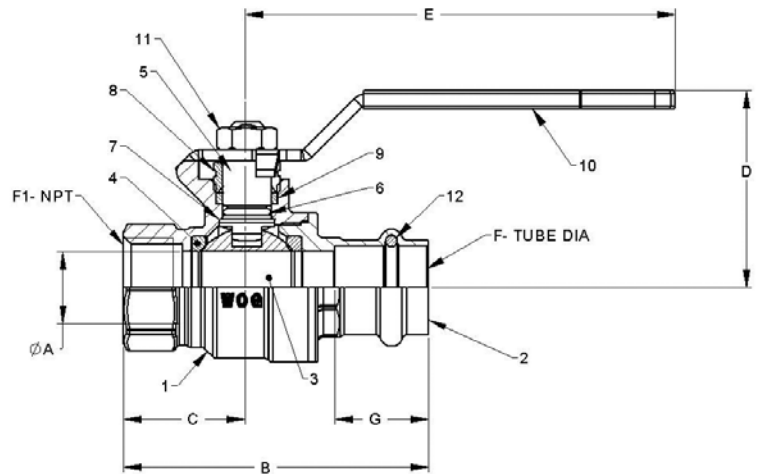

### DIMENSIONS

	UNITS	1/2" DN15	3/4" DN20	1" DN25	1-1/4" DN32	1-1/2" DN40	2" DN50
A-PORT DIA	INCHES	0.51	0.76	0.98	1.26	1.50	2.00
	mm	13	19	25	32	38	51
B	INCHES	2.77	3.23	3.71	4.12	4.86	6.14
	mm	70	82	94	105	123	156
C	INCHES	1.14	1.31	1.53	1.71	1.88	2.19
	mm	29	33	39	43	48	56
D	INCHES	1.46	1.93	2.10	2.33	2.52	2.96
	mm	37	49	53	59	64	75
E	INCHES	3.14	4.35	4.35	5.00	5.00	6.90
	mm	80	110	110	127	127	175
F-TUBE DIA	INCHES	0.63	0.88	1.13	1.38	1.63	2.13
	mm	15	20	25	32	40	50
F1 NPT	Inches	1/2"-14	3/4"-14	1"-11.5	1-1/4"-11.5	1-1/2"-11.5	2"-11.5
G	INCHES	0.83	1.00	1.00	1.02	1.42	1.57
	mm	21	25	25	26	36	40
Cv		18	40	72	112	161	287

The information presented on this sheet is correct at the time of publication. Milwaukee Valve reserves the right to change design, and/or material specifications without notice. For the Installation, Operation and Maintenance Manual (IOM) see the Technical/Service Information section on our website. For the most current information access [www.milwaukeevalve.com](http://www.milwaukeevalve.com)



# BA-491B\* 1/2"-2"



Brass Ball Valve

Two Piece

Full Port

250 psig @ 250°F†

Press x Threaded Ends

With Extension Stem & Memory Stop

Blow-Out Proof Stem

\*Not intended for use in potable water.

## MATERIALS LIST

ITEM	PART	MATERIALS	ASTM SPEC.
1	Body	Brass, Forged	B283
2	Tailpiece	Brass, Forged	B283
3	Ball	CP Brass Ball	B283
4	Ball Seat	PTFE	Commercial
5	Stem	Brass	B124
6	Stem O-Ring	Buna-N	
7	Thrust Washer	PTFE	Commercial
8	Gland Nut	Brass	B124
9	Packing	PTFE	Commercial
10	Handle	Steel w/Zinc Plating	B633
11	Handle Bolt	Steel w/Zinc Plating	Commercial
12	Tube O-Ring	EPDM	D2000 NSF61
13	Stem Stop Plate	Steel w/Zinc Plating	Commercial
14	Internal Extension Tube	Steel w/Zinc Plating	Commercial
15	External Extension Tube	Steel w/Zinc Plating	Commercial
16	Upper Stem Adaptor	Steel w/Zinc Plating	Commercial
17	Memory Stop	Steel w/Zinc Plating	Commercial

†Ultra Press Valves are designed and qualified for use in copper tubing systems only, Types K, L, & M per ASTM B88.

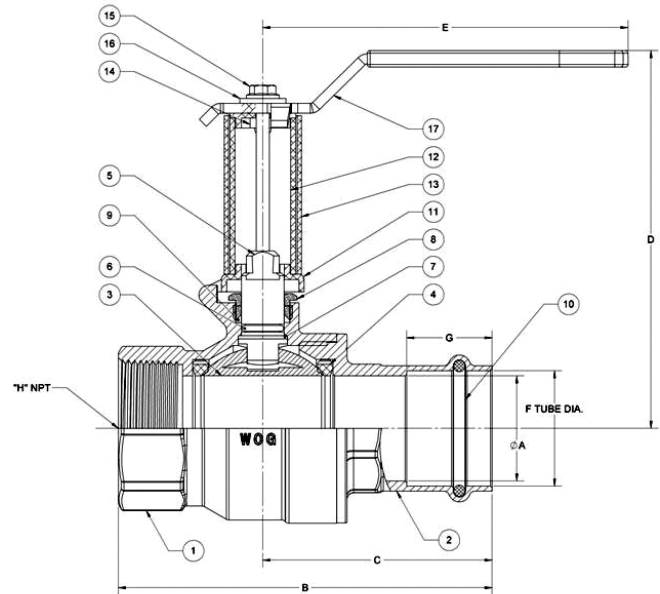

## DIMENSIONS

	UNITS	1/2" DN15	3/4" DN20	1" DN25	1-1/4" DN32	1-1/2" DN40	2" DN50
A-PORT DIA	INCHES	0.51	0.76	0.98	1.26	1.50	2.01
	mm	13	19	25	32	38	51
B	INCHES	2.76	3.58	3.98	4.51	5.50	6.44
	mm	70	91	101	115	140	164
C	INCHES	1.63	1.92	2.18	2.75	3.46	3.46
	mm	41	49	55	70	88	88
D	INCHES	3.55	4.08	4.28	4.53	4.65	5.13
	mm	90	104	109	115	118	130
E	INCHES	3.28	4.38	4.38	4.38	6.97	6.97
	mm	83	111	111	111	177	177
F TUBE Ø	INCHES	0.63	0.88	1.13	1.38	1.64	2.13
	mm	16	22	29	35	42	54
G	INCHES	0.83	0.99	0.99	1.02	1.42	1.58
	mm	21	25	25	26	36	40
H	THRD SIZE	1/2" NPT	3/4" NPT	1" NPT	1-1/4" NPT	1-1/2" NPT	2" NPT
Cv		18	40	72	112	161	287

The information presented on this sheet is correct at the time of publication. Milwaukee Valve reserves the right to change design, and/or material specifications without notice. For the Installation, Operation and Maintenance Manual (IOM) see the Technical/Service Information section on our website. For the most current information access [www.milwaukeevalve.com](http://www.milwaukeevalve.com)



# BA-491S\* 1/2"-2"



Brass Ball Valve

Two Piece

Full Port

250 psig @ 250°F†

Press x Threaded Ends

With Extension Stem & Memory Stop

Blow-Out Proof Stem

\*Not intended for use in potable water.

## MATERIALS LIST

ITEM	PART	MATERIALS	ASTM SPEC.
1	Body	Brass, Forged	B283
2	Tailpiece	Brass, Forged	B283
3	Ball	316 S.S.	A276
4	Ball Seat	PTFE	Commercial
5	Stem	316 S.S.	A276
6	Stem O-Ring	Buna-N	
7	Thrust Washer	PTFE	Commercial
8	Gland Nut	Brass	B124
9	Packing	PTFE	Commercial
10	Handle	Steel w/Zinc Plating	B633
11	Handle Bolt	Steel w/Zinc Plating	Commercial
12	Tube O-Ring	EPDM	D2000 NSF61
13	Stem Stop Plate	Steel w/Zinc Plating	Commercial
14	Internal Extension Tube	Steel w/Zinc Plating	Commercial
15	External Extension Tube	Steel w/Zinc Plating	Commercial
16	Upper Stem Adaptor	Steel w/Zinc Plating	Commercial
17	Memory Stop	Steel w/Zinc Plating	Commercial

\*Ultra Press Valves are designed and qualified for use in copper tubing systems only, Types K, L, & M per ASTM B88.

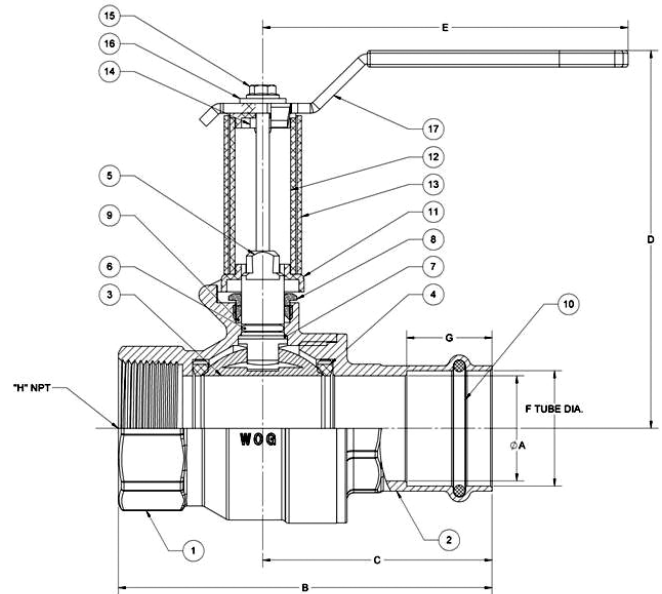

## DIMENSIONS

	UNITS	1/2" DN15	3/4" DN20	1" DN25	1-1/4" DN32	1-1/2" DN40	2" DN50
A-PORT DIA	INCHES	0.51	0.76	0.98	1.26	1.50	2.01
	mm	13	19	25	32	38	51
B	INCHES	2.76	3.58	3.98	4.51	5.50	6.44
	mm	70	91	101	115	140	164
C	INCHES	1.63	1.92	2.18	2.75	3.46	3.46
	mm	41	49	55	70	88	88
D	INCHES	3.55	4.08	4.28	4.53	4.65	5.13
	mm	90	104	109	115	118	130
E	INCHES	3.28	4.38	4.38	4.38	6.97	6.97
	mm	83	111	111	111	177	177
F TUBE Ø	INCHES	0.63	0.88	1.13	1.38	1.64	2.13
	mm	16	22	29	35	42	54
G	INCHES	0.83	0.99	0.99	1.02	1.42	1.58
	mm	21	25	25	26	36	40
H	THRD SIZE	1/2" NPT	3/4" NPT	1" NPT	1-1/4" NPT	1-1/2" NPT	2" NPT
Cv		18	40	72	112	161	287

The information presented on this sheet is correct at the time of publication. Milwaukee Valve reserves the right to change design, and/or material specifications without notice. For the Installation, Operation and Maintenance Manual (IOM) see the Technical/Service Information section on our website. For the most current information access [www.milwaukeevalve.com](http://www.milwaukeevalve.com)



# THE INSULATOR/MS

## Bronze & Brass Ball Valves

Milwaukee Valve's insulated extension handle is designed to prevent condensation and other extraneous moisture from entering your insulated piping system, while also minimizing thermal energy loss from the system via metal extension tubes, levers, and similar parts.

Our handle design incorporates a unique memory stop feature that requires no disassembly or removal of the handle to engage and make adjustments.

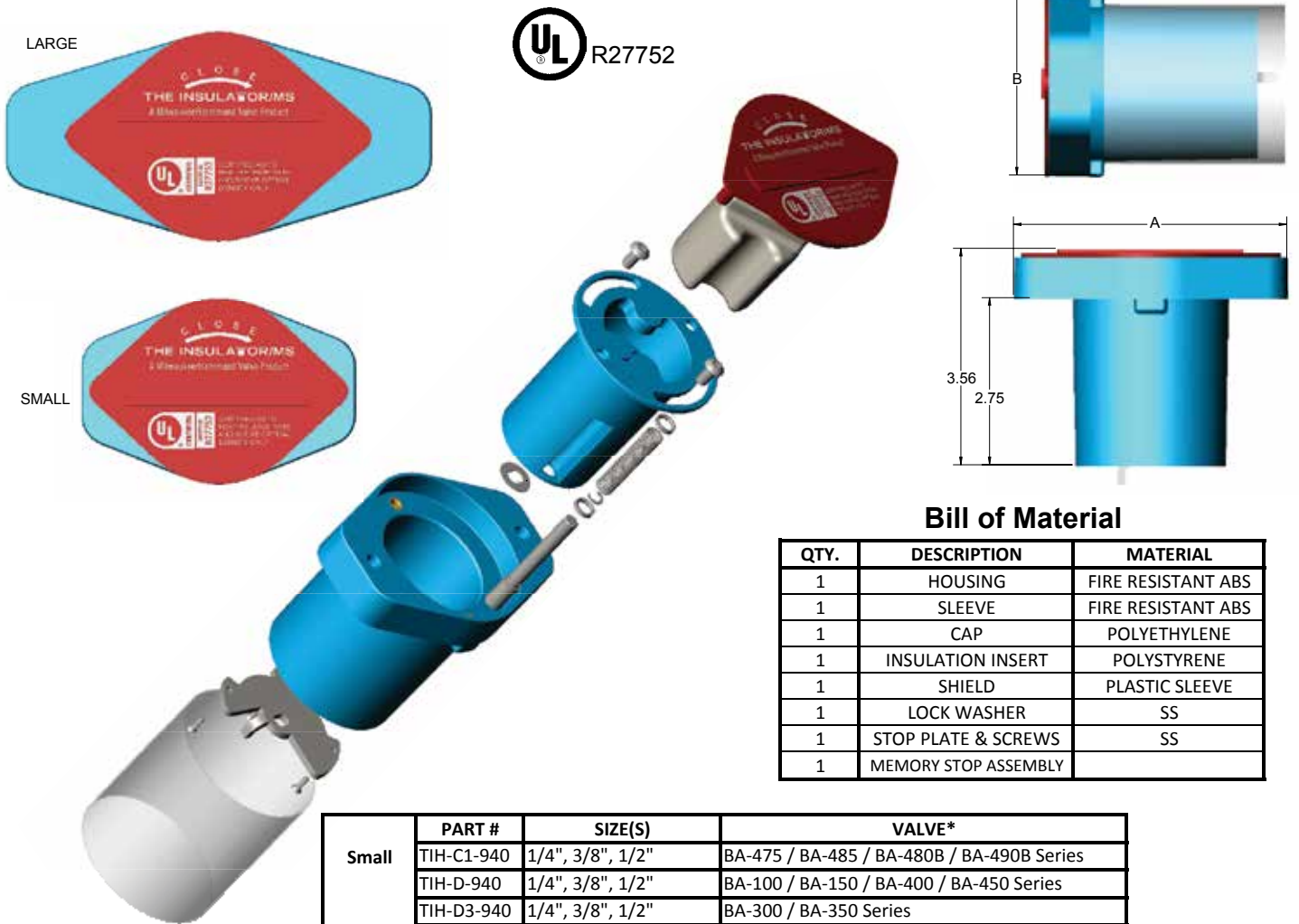

### Bill of Material

QTY.	DESCRIPTION	MATERIAL
1	HOUSING	FIRE RESISTANT ABS
1	SLEEVE	FIRE RESISTANT ABS
1	CAP	POLYETHYLENE
1	INSULATION INSERT	POLYSTYRENE
1	SHIELD	PLASTIC SLEEVE
1	LOCK WASHER	SS
1	STOP PLATE & SCREWS	SS
1	MEMORY STOP ASSEMBLY	

	PART #	SIZE(S)	VALVE*
Small	TIH-C1-940	1/4", 3/8", 1/2"	BA-475 / BA-485 / BA-480B / BA-490B Series
	TIH-D-940	1/4", 3/8", 1/2"	BA-100 / BA-150 / BA-400 / BA-450 Series
	TIH-D3-940	1/4", 3/8", 1/2"	BA-300 / BA-350 Series
A - 4.50	TIH-F-940	1"	BA-100 / BA-150 Series
		3/4"	BA-100 / BA-150 / BA-400 / BA-450 Series
	TIH-F3-940	3/4"	BA-300 / BA-350 Series
B - 3.06	TIH-H1-940	3/4", 1", 1 1/4", 1 1/2"	BA-475 / BA-485 / BA-480B / BA-490B Series
Large	TIH-J-940	2"	BA-100 / BA-150 Series
		1 1/4", 1 1/2"	BA-100 / BA-150/BA-400 / BA-450 Series
		1"	BA-400 / BA-450 Series
A - 7.00	TIH-J1-940	2"	BA-475 / BA-485 / BA-480B / BA-490B Series
	TIH-J3-940	1", 1 1/4", 1 1/2"	BA-300 / BA-350 Series
	TIH-K-940	2"	BA-400 / BA-450 Series
B - 3.44	TIH-K3-940	2"	BA-300 / BA-350 Series

To order factory assembled to the valve use suffix TIH (Threaded Only)  
Milwaukee Valve will not factory install (TIH) handle on solder end valves.

\*Will fit our equivalent Ultrapure Low Lead Valves.

The information presented on this sheet is correct at the time of publication. Milwaukee Valve reserves the right to change design, and/or material specifications without notice. For the Installation, Operation and Maintenance Manual (IOM) see the Technical/Service Information section on our website. For the most current information access [www.milwaukeevalve.com](http://www.milwaukeevalve.com)



# THE INSULATOR/MS\*

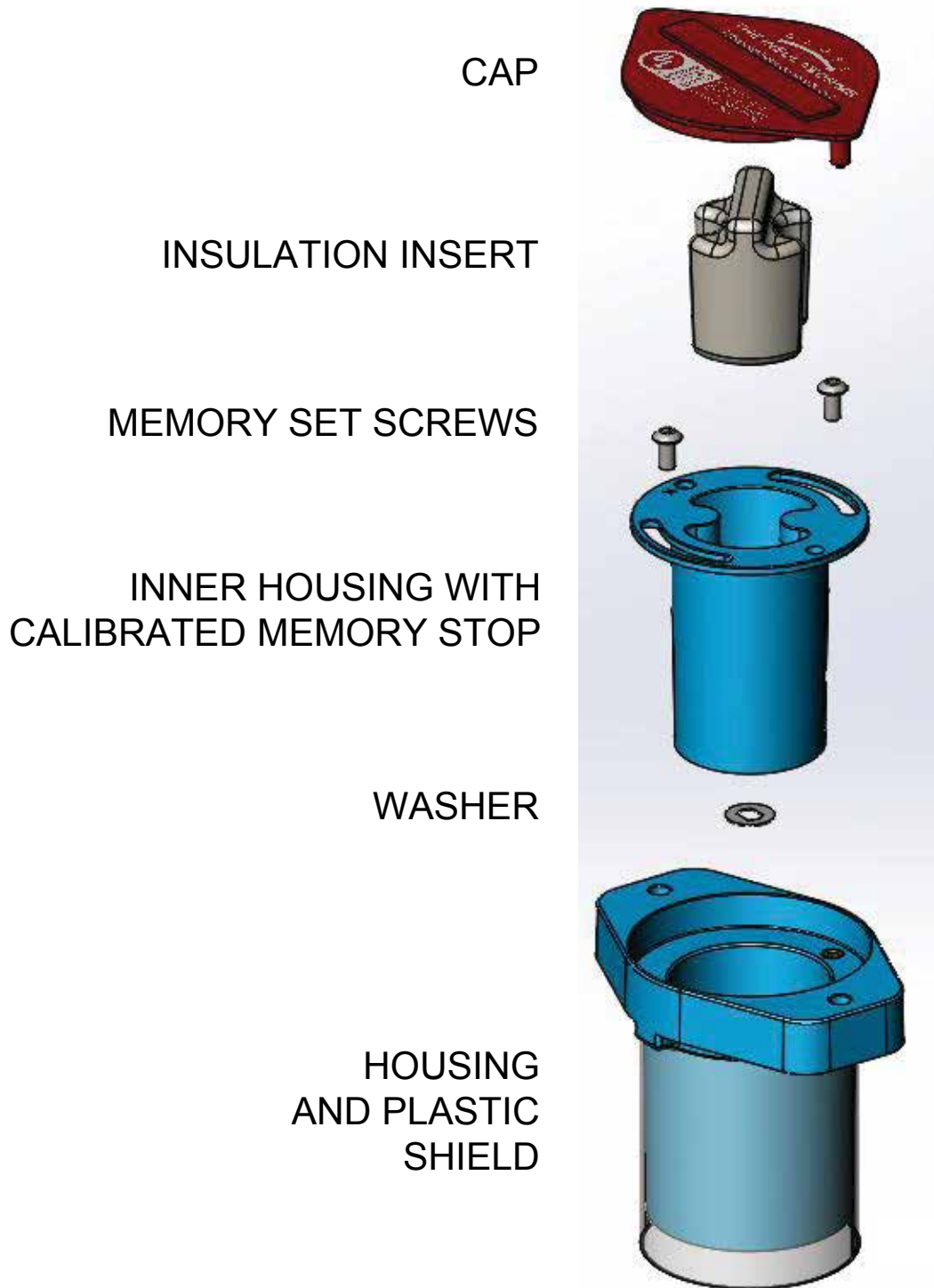

\* To order factory assembled to the valve use suffix TIH (Threaded Only) Milwaukee Valve will not factory install (TIH) handle on solder end valves.

The information presented on this sheet is correct at the time of publication. Milwaukee Valve reserves the right to change design, and/or material specifications without notice. For the Installation, Operation and Maintenance Manual (IOM) see the Technical/Service Information section on our website. For the most current information access [www.milwaukeevalve.com](http://www.milwaukeevalve.com)



# OPTIONS

BA100/150  
BA300/350  
BA400/450

**OH & LO** Milwaukee offers two styles of oval handles, standard oval and a padlocking oval design. Oval handles are intended for several different applications, they can be installed where a standard lever handle might encounter interference from adjoining piping. Oval handles can also prevent accidental valve operations, since they have less projection than a lever handle, and require more turning force to operate. OSHA requires the use of oval handles in many installations for safety reasons. The locking handle design will accommodate a standard 5/16" pad-lock or other types of valve lockouts. The standard oval handle can be field or factory mounted on BA100/300/400 series valves up to 2", and the locking oval handle can be used on sizes up to 1".

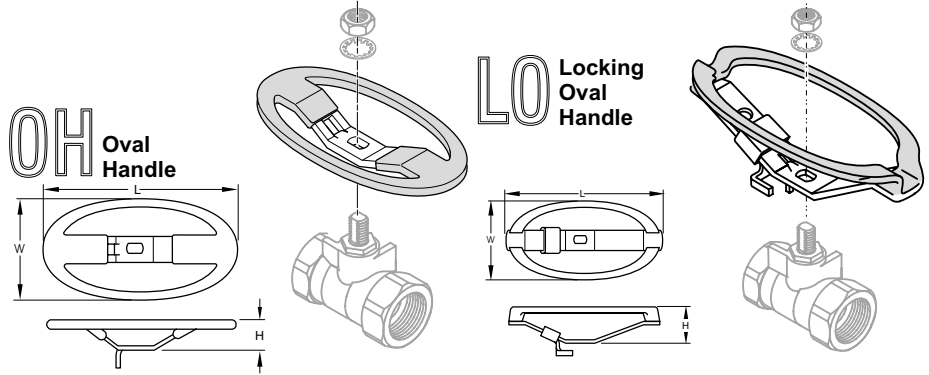

## SH Stainless Steel Handle

The "SH" handle option adds a 316 stainless steel handle and nut to a standard bronze ball valve. This option is intended for harsh environments like areas subject to salt water spray, high humidity, harsh cleaning chemicals, etc.

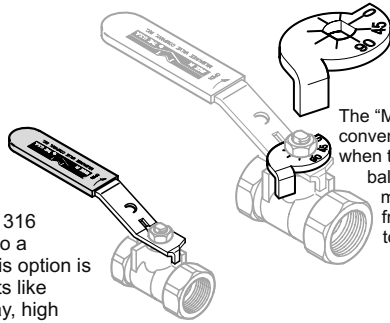

## MS Memory Stop

The "MS" Memory Stop offers the convenience of a preset stop when the valve is used in a balancing application. The memory stop can be set from the full closed position, to any preset opening point.

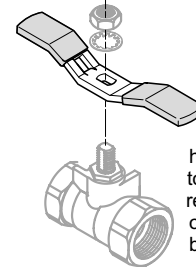

## TH Tee Handle

Tee handles offer the same installation space savings as oval handles, with a slightly shorter end to end dimension. Tee handles require more handle force to operate, so accidental openings can be reduced.

## CL Chain Lever

Chain lever handle kits are designed for installations where overhead ball valves need to be operated on a regular basis. A length of chain is attached to either end of the handle, so that the operator needs only to pull down on the appropriate chain to open or close the valve.

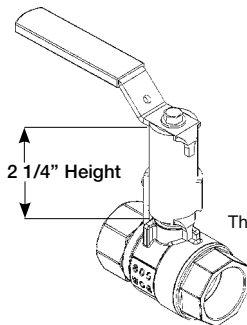
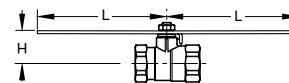

## XM Extension Handle with Memory Stop

The "XM" stem extension is all-metallic with an adjustable memory stop. This option is designed for installations where pipe insulation would make standard handles inoperable. The stem extension can also be used where a handle needs to be raised above an adjoining obstruction. Installations where the valve is mounted behind a panel can be an ideal place for the "XM" stem extension. The adjustable memory stop allows the valve opening to be limited to a preset position. This option can be ordered with or without the memory stop.

Valve Series	Valve Size	Length	Height
BA100/150	1/4" - 1/2"	8 3/8"	1 1/4"
BA100/150	3/4" - 1"	11 1/2"	1 1/2"
BA100/150	1 1/4" - 1 1/2"	15 1/4"	2"
*BA300/350	1/4" - 1/2"	8 3/8"	1 1/4"
*BA300/350	3/4" - 1"	11 1/2"	1 1/2"
*BA300/350	1 1/4" - 1 1/2"	15 1/4"	2"

\*Not available above 3/4"

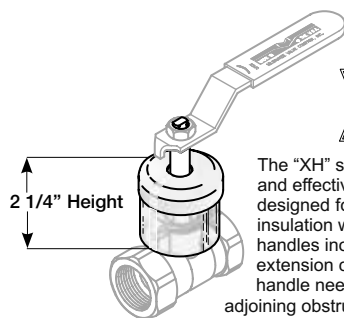

## XH Extension Stem

The "XH" stem extension is simple and effective design. This option is designed for installations where pipe insulation would make standard handles inoperable. The stem extension can also be used where a handle needs to be raised above an adjoining obstruction. Installations where the valve is mounted behind a panel can be an ideal place for the "XH" stem extension. The external plastic shield helps to keep the insulation away from the stem extension, providing years of trouble free operation.

## LD Locking Device

The "LD" Locking Handle offers the end user the security of a pad lockable handle. The handle can be locked in either the full open position, or full closed by adding a standard padlock. OSHA requires the use of locking handles in many installations for safety reasons. The locking handle design will accommodate a standard 5/16" pad-lock or other types of valve lockouts. The handle and locking device are also manufactured of stainless steel material for additional strength and corrosion resistance.

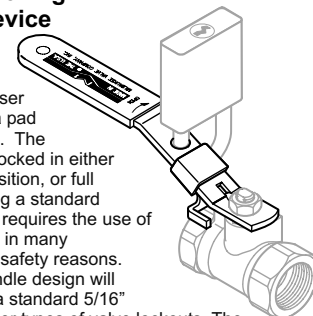

The information presented on this sheet is correct at the time of publication. Milwaukee Valve reserves the right to change design, and/or material specifications without notice. For the Installation, Operation and Maintenance Manual (IOM) see the Technical/Service Information section on our website. For the most current information access [www.milwaukeevalve.com](http://www.milwaukeevalve.com)



# OPTIONS\*

BA200/250  
BA-475B/485B  
BA480B/BA490B

## XH Extension Handle

The "XH" stem extension is a simple and effective design. This option is designed for installations where pipe insulation would make standard handles inoperable. The stem extension can also be used where a handle needs to be raised above an adjoining obstruction. Installations where the valve is mounted behind a panel can be an ideal place for the "XH" stem extension.



## SH Stainless Steel Handle

The "SH" handle option adds a 316 stainless steel handle and nut to a standard bronze ball valve. This option is intended for harsh environments like areas subject to salt water spray, high humidity, harsh cleaning chemicals, etc.

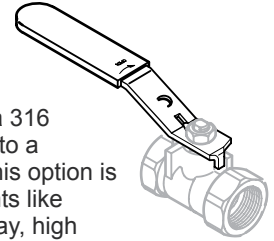

## MS Memory Stop

The "MS" Memory Stop provides an adjustable stop when the valve is used in a balancing application. The memory stop can be set to any preset opening point.

## OH Oval Handle

Oval handles can be installed where a standard lever handle might encounter interference from adjoining piping. Oval handles can also prevent accidental valve operations, since they have less projection than a lever handle, and require more turning force to operate. The standard oval handle can be field or factory mounted on BA-200/BA-475B series valves up to 2".

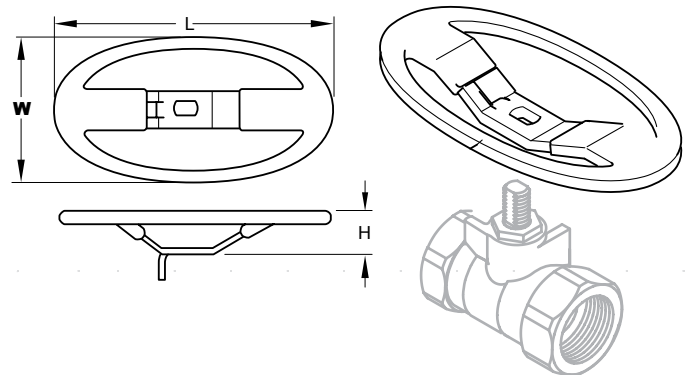

## TH Tee Handle

Tee handles offer the same installation space savings as oval handles, with a slightly shorter end to end dimension. Tee handles require more handle force to operate, so accidental openings can be reduced.

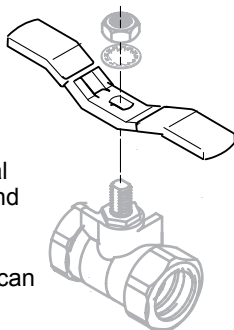

**\*Locking Lever Handle Is Available.**

The information presented on this sheet is correct at the time of publication. Milwaukee Valve reserves the right to change design, and/or material specifications without notice. For the Installation, Operation and Maintenance Manual (IOM) see the Technical/Service Information section on our website. For the most current information access [www.milwaukeevalve.com](http://www.milwaukeevalve.com)

