

Product Data

Variable Speed Modular Multi-position Air Handlers 2–5 Tons

TAM9A0A24V21DB
TAM9A0B30V31DB
TAM9A0C36V31DB
TAM9A0C42V41DB
TAM9A0C48V41DB
TAM9A0C60V51DB

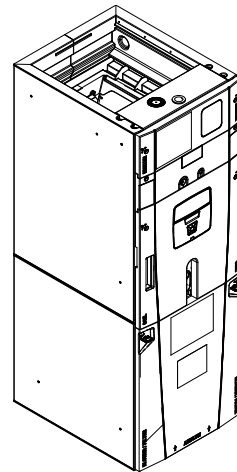

Note: "Graphics in this document are for representation only. Actual model may differ in appearance."

Note: For use with BAYEA series heaters ONLY

Features and Benefits

- Unique cabinet design
 - 2% or less air leakage
 - Precision applied — durable door seals
 - Specially designed air seal around refrigerant, condensate and conduit connections
 - Double wall foamed cabinet system
 - R-4.2 Insulating Value (Avg Insulating Value R-8.2)
 - No loose fiber design
 - Smooth cleanable interior design
 - Sweat eliminating design
 - Composite foamed cabinet doors
 - Water proof cabinet design
 - Integrated horizontal drain pans
 - Modular cabinet
- Multi-position up/down flow horizontal left/right
- Communicating or 24 Volt control
- Control Display Assembly (CDA) with enhanced diagnostic information and setup capability
- Side return option (sold as accessory)
- Control board protection pocket built into cabinet wall
- Pre-marked Conduit Connection Locations
- Alert port to view control board codes without door removal
- Alert code notification
- Low voltage terminal connection point
- Phillips head door fasteners
- **Vortica**[®] blower with polarized plug connections and integrated slide deck for easy removal
- Aluminum coil with integrated slide deck for easy removal and polarized plug connections on coil EEV
- Patented enhanced coil fin
- Electronic Expansion Valve (EEV) with low ambient and low superheat compressor protection
- Dual refrigerant compatible as shipped
- Slide in electric heaters with polarized plug connections (sold as accessory)
- Slide in hot water coils with polarized plug connections (sold as accessory)
- UVC light kit with safety switch and polarized plug connections (sold as accessory)
- Labeled panels and connections
- Molded in 1" standard filter rail
- Variable speed ECM motor
- Soft start fan motor operation
- **Comfort R**[™] mode
- Built in fan delay modes
- Maximum width of 23.5"
- Compact 20.8" depth with doors removed
- Fused 24v power
- Safety door switch
- **5 Year Warranty**
- **10 Year Warranty Registered**
- **Optional Extended Warranty Available**

Optional Accessories

Accessory Number	Description	Fits Cabinet Size (a)
BAYEAAC04BK1	Electric Heater, 4kW, Breaker, 24V Control, 1 Ph	A to C
BAYEAAC04LG1	Electric Heater, 4kW, Lugs, 24VControl, 1 Ph	A to C
BAYEAAC05BK1	Electric Heater, 5kW, Breaker, 24V Control, 1 Ph	A to C
BAYEAAC05LG1	Electric Heater, 5kW, Lugs, 24VControl, 1 Ph	A to C
BAYEAAC08BK1	Electric Heater, 8kW, Breaker, 24V Control, 1 Ph	A to C
BAYEAAC08LG1	Electric Heater, 8kW, Lugs, 24VControl, 1 Ph	A to C
BAYEAAC10BK1	Electric Heater, 10kW, Breaker, 24V Control, 1 Ph	A to C
BAYEAAC10LG1	Electric Heater, 10kW, Lugs, 24VControl, 1 Ph	A to C
BAYEABC15BK1	Electric Heater, 15kW, Breaker, 24V Control, 1 Ph	B to C
BAYEABC20BK1	Electric Heater, 20kW, Breaker, 24VControl, 1 Ph	C
BAYEACC25BK1	Electric Heater, 25kW, Breaker, 24V Control, 1 Ph	C
BAYEAAC10LG3	Electric Heater, 10kW, Lugs, 24VControl, 3 Ph	A to C
BAYEABC15LG3	Electric Heater, 15kW, Lugs, 24V Control, 3 Ph	B to C
BAYSUPFLGAA	Supply Duct Flange A	A
BAYSUPFLGBA	Supply Duct Flange B	B
BAYSUPFLGCA	Supply Duct Flange C	C
BAYRETFLGAA	Return Duct Flange A	A
BAYRETFLGBA	Return Duct Flange B	B
BAYRETFLGCA	Return Duct Flange C	C
BAYSRKIT100A	Side Return Kit	A to C
BAYFLR1620A	High Velocity Filter Kit, 16" x 20" x 1" (10 filters)	A
BAYFLR2020A	High Velocity Filter Kit, 20" x 20" x 1" (10 filters)	B
BAYFLR2220A	High Velocity Filter Kit, 22" x 20" x 1" (10 filters)	C
TASB175SB (b) (c)	Plenum Stand with integrated sound baffle A	A
TASB215SB (b) (c)	Plenum Stand with integrated sound baffle B	B
TASB235SB (b) (c)	Plenum Stand with integrated sound baffle C	C
MITISRKIT01A	Side Return Kit with 16" x 20" Filter	A to C
BAYFRKIT175	Front Return Kit for 17.5" Cabinet	A
BAYFRKIT210	Front Return Kit for 21.0" Cabinet	B
BAYFRKIT235	Front Return Kit for 23.5" Cabinet	C
TAYBASETAMA	Downflow Sub-Base Kit	A to C
BAYBAFKT175A (d)	Sound Baffle Kit for 17.5" Cabinet	A
BAYBAFKT215A (d)	Sound Baffle Kit for 21.0" Cabinet	B
BAYBAFKT235A (d)	Sound Baffle Kit for 23.5" Cabinet	C
TASSBK175 (b) (e) (f)	Sound Baffle Kit for 17.5" Cabinet	A
TASSBK210 (b) (e) (f)	Sound Baffle Kit for 21.0" Cabinet	B
TASSBK235 (b) (e) (f)	Sound Baffle Kit for 23.5" Cabinet	C
BAYICKSKIT01A	Internal Condensate Switch Kit	A to C
BAYHHKIT001A	Horizontal Hanger Kit	A to C
BAYUVCLK001A	UV Lights	A to C
BAYLVKIT100A	Low Voltage Conduit Entry Kit	A to C
BAYSPEKT200A	Single Power Entry Kit	A to C
BAYWAAA05SC1AA	Hydronic Coil — 50,000 BTUH — Slide-in	A to A
BAYWABB07SC1AA	Hydronic Coil — 70,000 BTUH — Slide-in	B to B
BAYWACC08SC1AA	Hydronic Coil — 80,000 BTUH — Slide-in	C to C
BAYWACC11SC1AA	Hydronic Coil — 100,000 BTUH — Add on	C to C
BAYWAKIT24VAC	Hydronic Heater Relay Kit — (used in Communicating mode only)	A to C
BAYINSKT175A	Solcoustic® Liner Kit for 17.5" cabinet	A
BAYINSKT215A	Solcoustic® Liner Kit for 21.5" cabinet	B
BAYINSKT235A	Solcoustic® Liner Kit for 23.5" cabinet	C
BAYCNDPIP01A	3/4" PVC Threaded Pipe Kit foam Seal (10 per box)	A to C
BAYAHMIKIT001A	EMI/EFI Air Handler Electronic noise kit for variable speed blower motor	A to C

(a) A Cabinet is 17.5" wide, B Cabinet is 21.5" wide, C Cabinet is 23.5" wide.

(b) Contact your distributor for information.

(c) In open air applications, the plenum stand with sound baffle provides sound reduction.

(d) Mounts inside air handler filter channel.

(e) In return plenum applications, use TASSBK for sound reduction.

(f) Mounts to TASB original plenum stand without integrated baffle.

Unique Cabinet Design Features and Benefits

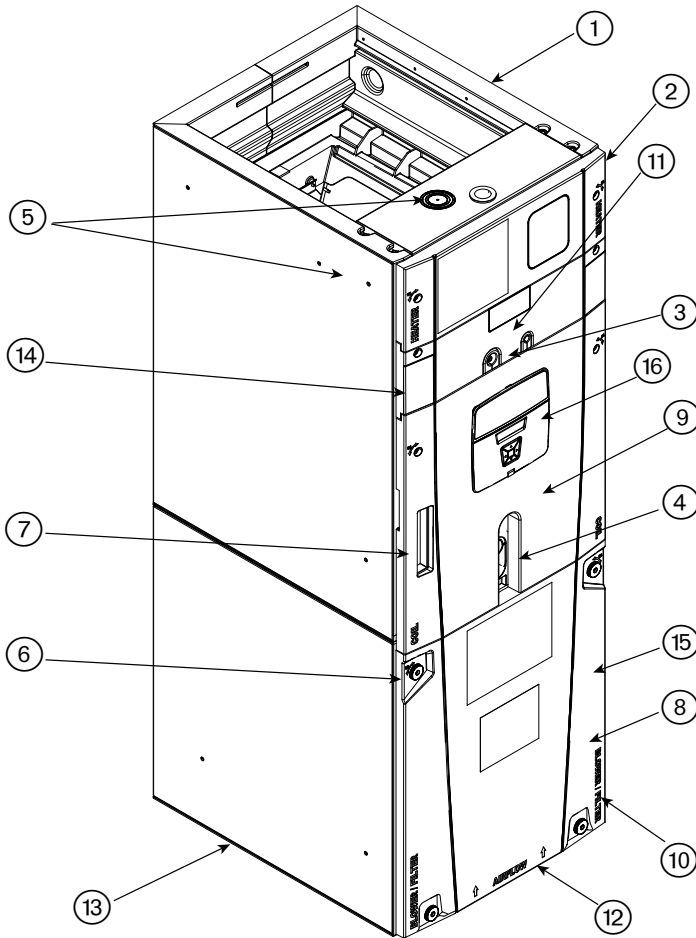

1	Unique Cabinet Design
	— Double wall foamed cabinet system
	— Waterproof Cabinet Design
	— R-4.2 Insulating Value (Avg Insulating Value R-8.2)
	— Composite Foamed Cabinet Doors
	— Sweat Eliminating Cabinet Design
	— Loose Fiber Eliminating Design
	— Smooth Cleanable Cabinet Design
2	Precision Durable Door Seals
3	Refrigeration Connections
4	Condensate Connections
5	Conduit Connection Locations
	— Dimples or target to mark Conduit Connection locations on Left, Right, and Top
6	Easy access large thumb screws
7	Alert Code Viewport
	— Alert codes can be Viewed Without Door Removal
	— Control Protection Pocket
8	Vortica™ Blower and Deck
	— Polarized Plug on Blower
9	All Aluminum Coil
	— Integrated Slide Deck for Easy Removal
	— Polarized Plug connections on Coil EEV
	— Patented Enhanced Coil Fin
10	Labeled Panels and Connections
11	Electronic Expansion Valve (EEV)
	— Low Ambient and Low Superheat Protection
	— Dual Refrigerant <u>Compatible</u> as Shipped
12	Maximum width is 23.5"
13	Compact 20.8" Depth with Doors Removed
14	Integrated Horizontal Drain Pans
15	Safety Door Switch
	— Fused 24V Power
16	Control Display Assembly (CDA)

PRODUCT SPECIFICATIONS

MODEL	TAM9A0A24V21DB	TAM9A0B30V31DB	TAM9A0C36V31DB
RATED VOLTS/PH/HZ.	200 — 230/1/60	200 — 230/1/60	200 — 230/1/60
RATINGS ^(a)	See O.D. Specifications	See O.D. Specifications	See O.D. Specifications
INDOOR COIL — Type	Plate Fin	Plate Fin	Plate Fin
Rows — F.P.I.	3 — 14	3 — 14	3 — 14
Face Area (sq. ft.)	3.67	5.04	5.50
Tube Size (in.)	3/8	3/8	3/8
Refrigerant Control	EEV	EEV	EEV
Drain Conn. Size (in.) ^(b)	3/4 NPT	3/4 NPT	3/4 NPT
DUCT CONNECTIONS	See Outline Drawing	See Outline Drawing	See Outline Drawing
INDOOR FAN — Type	Centrifugal	Centrifugal	Centrifugal
Diameter-Width (In.)	11 x 8	11 x 10	11 x 10
No. Used	1	1	1
Drive — No. Speeds	Direct — Variable	Direct — Variable	Direct — Variable
CFM vs. in. w.g.	See Fan Performance Table	See Fan Performance Table	See Fan Performance Table
No. Motors — H.P.	1 — 1/2	1 — 1/2	1 — 1/2
Motor Speed RPM	Variable ECM	Variable ECM	Variable ECM
Volts/Ph/Hz	208–230/1/60	208–230/1/60	208–230/1/60
F.L. Amps	3.0 — 4.1 ^(c)	3.0 — 4.1 ^(c)	3.0 — 4.1 ^(c)
FILTER			
Filter Furnished?	No	No	No
Type Recommended	Throwaway	Throwaway	Throwaway
No.-Size-Thickness	1 — 16 x 20 — 1 in.	1 — 20 x 20 — 1 in.	1 — 22 x 20 — 1 in.
REFRIGERANT	R-410A	R-410A	R-410A
Ref. Line Connections	Brazed	Brazed	Brazed
Coupling or Conn. Size-in. Gas	3/4	3/4	7/8
Coupling or Conn. Size-in. Liq.	3/8	3/8	3/8
DIMENSIONS	H x W x D	H x W x D	H x W x D
Crated (In.)	51 x 20 x 24.5	56.8 x 23.5 x 24.5	58 x 25.5 x 24.5
Uncrated	49.9 x 17.5 x 21.8	55.7 x 21.3 x 21.8	56.9 x 23.5 x 21.8
WEIGHT			
Shipping (Lbs.)/Net (Lbs.)	126/116	150/138	157/146

^(a) These Air Handlers are AHRI certified with various Split System Air Conditioners and Heat Pumps (AHRI STANDARD 210/240).

^(b) 3/4" Male Plastic Pipe (Ref.:ASTM 1785–76)

^(c) Check motor nameplate for actual FLA

PRODUCT SPECIFICATIONS

MODEL	TAM9A0C42V41DB	TAM9A0C48V41DB	TAM9A0C60V51DB
RATED VOLTS/PH/HZ.	200 — 230/1/60	200 — 230/1/60	200 — 230/1/60
RATINGS ^(a)	See O.D. Specifications	See O.D. Specifications	See O.D. Specifications
INDOOR COIL — Type	Plate Fin	Plate Fin	Plate Fin
Rows — F.P.I.	4 — 14	4 — 14	4 — 14
Face Area (sq. ft.)	5.04	5.96	5.96
Tube Size (in.)	3/8	3/8	3/8
Refrigerant Control	EEV	EEV	EEV
Drain Conn. Size (in.) ^(b)	3/4 NPT	3/4 NPT	3/4 NPT
DUCT CONNECTIONS	See Outline Drawing	See Outline Drawing	See Outline Drawing
INDOOR FAN — Type	Centrifugal	Centrifugal	Centrifugal
Diameter-Width (In.)	11 x 10	11 x 10	11 x 10
No. Used	1	1	1
Drive — No. Speeds	Direct — Variable	Direct — Variable	Direct — Variable
CFM vs. in. w.g.	See Fan Performance Table	See Fan Performance Table	See Fan Performance Table
No. Motors — H.P.	1 — 1/2	1 — 3/4	1 — 1
Motor Speed RPM	Variable ECM	Variable ECM	Variable ECM
Volts/Ph/Hz	208–230/1/60	208–230/1/60	208–230/1/60
F.L. Amps	3.0 — 4.1 ^(c)	5.0 — 6.1 ^(c)	6.4 — 7.5 ^(c)
FILTER			
Filter Furnished?	No	No	No
Type Recommended	Throwaway	Throwaway	Throwaway
No.-Size-Thickness	1 — 22 x 20 — 1 in.	1 — 22 x 20 — 1 in.	1 — 22 x 20 — 1 in.
REFRIGERANT	R-410A	R-410A	R-410A
Ref. Line Connections	Brazed	Brazed	Brazed
Coupling or Conn. Size-in. Gas	7/8	7/8	7/8
Coupling or Conn. Size-in. Liq.	3/8	3/8	3/8
DIMENSIONS	H x W x D	H x W x D	H x W x D
Crated (In.)	58 x 25.5 x 24.5	62.8 x 25.5 x 24.5	62.8 x 25.5 x 24.5
Uncrated	56.9 x 23.5 x 21.8	61.7 x 23.5 x 21.8	61.7 x 23.5 x 21.8
WEIGHT			
Shipping (Lbs.)/Net (Lbs.)	162/150	174/162	175/163

^(a) These Air Handlers are AHRI certified with various Split System Air Conditioners and Heat Pumps (AHRI STANDARD 210/240).

^(b) 3/4" Male Plastic Pipe (Ref.:ASTM 1785–76)

^(c) Check motor nameplate for actual FLA.

TAM9 Air Flow Performance Tables

OUTDOOR MULTIPLIER (TONS)	TAM9A0A24 AIRFLOW PERFORMANCE										CONSTANT CFM MODE / CONSTANT TORQUE MODE									
	COOLING AIRFLOW SETTING	AIRFLOW POWER	EXTERNAL STATIC PRESSURE (Constant CFM / Torque)					CONSTANT CFM / Constant Torque					HEATING AIRFLOW SETTING	AIRFLOW POWER	EXTERNAL STATIC PRESSURE					
			0.1	0.3	0.5	0.7	0.9	0.1	0.3	0.5	0.7	0.9								
1.5 tons	290 CFM/ton	CFM Watts	407/546	430/403	398/NA	347/NA	255/NA	290 CFM/ton	CFM Watts	416	426	401	330	291						
	350 CFM/ton	CFM Watts	534/630	549/531	542/360	509/NA	445/NA	350 CFM/ton	CFM Watts	532	550	542	507	434						
	400 CFM/ton	CFM Watts	617/697	633/617	632/501	604/NA	559/NA	400 CFM/ton	CFM Watts	660	680	679	658	614						
	450 CFM/ton	CFM Watts	691/762	710/693	707/602	688/478	649/NA	450 CFM/ton	CFM Watts	690	710	709	690	651						
	290 CFM/ton	CFM Watts	593/680	613/595	607/470	583/208	527/132	290 CFM/ton	CFM Watts	593	613	608	582	527						
	350 CFM/ton	CFM Watts	717/783	733/717	733/632	714/519	678/355	350 CFM/ton	CFM Watts	714	734	734	716	679						
	400 † CFM/ton	CFM Watts	79/98	118/114	157/127	192/136	222/143	400 (e) CFM/ton	CFM Watts	75	115	153	189	218						
	450 CFM/ton	CFM Watts	810/868	827/811	827/740	813/652	782/543	450 CFM/ton	CFM Watts	862	881	884	874	849						
	290 CFM/ton	CFM Watts	108/128	152/146	194/161	233/173	265/182	290 CFM/ton	CFM Watts	122	168	213	254	290						
	350 CFM/ton	CFM Watts	903/954	918/902	920/839	909/764	884/674	350 CFM/ton	CFM Watts	899	917	921	912	889						
2 tons †	400 CFM/ton	CFM Watts	144/165	192/182	238/201	280/215	316/224	400 CFM/ton	CFM Watts	136	184	231	273	310						
	450 CFM/ton	CFM Watts	741/820	757/759	757/681	739/582	705/452	450 CFM/ton	CFM Watts	738	757	758	742	707						
	290 CFM/ton	CFM Watts	86/110	126/127	166/141	202/152	232/159	290 CFM/ton	CFM Watts	81	122	162	198	229						
	350 CFM/ton	CFM Watts	880/947	896/895	896/832	885/757	859/665	350 CFM/ton	CFM Watts	876	895	898	888	864						
	400 CFM/ton	CFM Watts	134/162	182/181	226/198	267/211	302/221	400 CFM/ton	CFM Watts	127	174	220	261	297						
	450 CFM/ton	CFM Watts	996/1059	1011/1011	1014/954	1006/887	985/807	450 CFM/ton	CFM Watts	1064	1083	1089	1084	1066						
	290 CFM/ton	CFM Watts	188/220	241/240	291/257	336/271	375/280	290 CFM/ton	CFM Watts	215	272	326	375	418						
	350 CFM/ton	CFM Watts	1120/1180	1135/1134	1137/1081	1129/1019	1108/946	350 CFM/ton	CFM Watts	1115	1133	1139	1133	1116						
	400 CFM/ton	CFM Watts	260/297	319/317	373/334	422/347	463/355	400 CFM/ton	CFM Watts	244	304	360	410	453						
	450 CFM/ton	CFM Watts	875/943	891/891	892/891	880/751	854/659	450 CFM/ton	CFM Watts	871	890	894	883	859						
2.5 tons	290 CFM/ton	CFM Watts	132/160	179/179	224/196	265/209	300/218	290 CFM/ton	CFM Watts	125	172	217	259	295						
	350 CFM/ton	CFM Watts	1045/1106	1060/1059	1063/1004	1055/939	1035/862	350 CFM/ton	CFM Watts	1040	1058	1064	1059	1041						
	400 CFM/ton	CFM Watts	215/248	270/268	321/285	369/299	409/308	400 CFM/ton	CFM Watts	202	257	310	358	401						
	450 CFM/ton	CFM Watts	1200/1257	1212/1211	1212/1159	1200/1099	1129/1030	450 CFM/ton	CFM Watts	1291	1302	1300	1220	1138						
	290 CFM/ton	CFM Watts	315/354	376/374	432/390	480/402	481/409	290 CFM/ton	CFM Watts	368	432	487	478	470						
	350 CFM/ton	CFM Watts	1358/1403	1333/1359	1256/1308	1177/1251	1095/1187	350 CFM/ton	CFM Watts	422	483	476	468	462						
	400 CFM/ton	CFM Watts	447/484	482/502	472/517	466/527	460/531	400 CFM/ton	CFM Watts	422	483	476	468	462						
	450 CFM/ton	CFM Watts	1200/1257	1212/1211	1212/1159	1200/1099	1129/1030	450 CFM/ton	CFM Watts	1291	1302	1300	1220	1138						
	290 CFM/ton	CFM Watts	315/354	376/374	432/390	480/402	481/409	290 CFM/ton	CFM Watts	368	432	487	478	470						
	350 CFM/ton	CFM Watts	1358/1403	1333/1359	1256/1308	1177/1251	1095/1187	350 CFM/ton	CFM Watts	422	483	476	468	462						
3 tons	400 CFM/ton	CFM Watts	638/713	638/900	675/900	600/713	-	400 CFM/ton	CFM Watts	-	-	-	-	-						
	450 CFM/ton	CFM Watts	1358/1403	1333/1359	1256/1308	1177/1251	1095/1187	450 CFM/ton	CFM Watts	422	483	476	468	462						
	290 CFM/ton	CFM Watts	315/354	376/374	432/390	480/402	481/409	290 CFM/ton	CFM Watts	368	432	487	478	470						
	350 CFM/ton	CFM Watts	1358/1403	1333/1359	1256/1308	1177/1251	1095/1187	350 CFM/ton	CFM Watts	422	483	476	468	462						
	400 CFM/ton	CFM Watts	638/713	638/900	675/900	600/713	-	400 CFM/ton	CFM Watts	-	-	-	-	-						
	450 CFM/ton	CFM Watts	1358/1403	1333/1359	1256/1308	1177/1251	1095/1187	450 CFM/ton	CFM Watts	422	483	476	468	462						
	290 CFM/ton	CFM Watts	315/354	376/374	432/390	480/402	481/409	290 CFM/ton	CFM Watts	368	432	487	478	470						
	350 CFM/ton	CFM Watts	1358/1403	1333/1359	1256/1308	1177/1251	1095/1187	350 CFM/ton	CFM Watts	422	483	476	468	462						
	400 CFM/ton	CFM Watts	638/713	638/900	675/900	600/713	-	400 CFM/ton	CFM Watts	-	-	-	-	-						
	450 CFM/ton	CFM Watts	1358/1403	1333/1359	1256/1308	1177/1251	1095/1187	450 CFM/ton	CFM Watts	422	483	476	468	462						

- † Factory Setting
- Status LED will blink once per 100 CFM requested. In torque mode, actual airflow may be lower.
- Torque mode will reduce airflow when static is above approximately 0.3" water column.
- All heating modes default to Constant CFM.
- Cooling airflow values are with wet coil, no filter

TAM9A0A24 Minimum Heating Airflow Settings

MODEL NO.	BAYEAC08BK1 BAYEAC08LG1 BAYEAC05BK1 BAYEAC05LG1	BAYEAC10BK1 BAYEAC10LG1	BAYEAC10LG3	BAYEACB15BK1 BAYEACB15LG3	BAYEABC20BK1
TAM9A0A24	638/713	638/900	600/713	-	-

WITHOUT HEAT PUMP / WITH HP — SEE AIR HANDLER NAMEPLATE FOR APPROVED COMBINATIONS

(e) Factory heating default setting is 430 CFM/ton

TAM9 Air Flow Performance Tables

TAM9A0B30 AIRFLOW PERFORMANCE CONSTANT CFM MODE / CONSTANT TORQUE MODE													
OUTDOOR MULTIPLIER (TONS)	EXTERNAL STATIC PRESSURE (Constant CFM / Constant Torque)			AIRFLOW POWER	COOLING AIRFLOW SETTING	AIRFLOW POWER	HEATING AIRFLOW SETTING	AIRFLOW POWER	EXTERNAL STATIC PRESSURE				
	0.1	0.3	0.5						0.7	0.9	0.1	0.3	0.5
1.5 tons	290 CFM/ton	492/581	442/397	408/NA	353/NA	221/NA	290 CFM/ton	CFM	485	437	393	349	300
	350 CFM/ton	576/664	553/515	527/NA	493/NA	472/NA	350 CFM/ton	CFM	574	545	517	489	457
	400 CFM/ton	644/730	633/598	612/403	590/NA	563/NA	400 CFM/ton	CFM	643	624	605	583	559
	450 CFM/ton	711/794	708/673	691/510	678/NA	656/NA	450 CFM/ton	CFM	709	698	684	669	649
	290 CFM/ton	627/713	611/576	589/369	568/NA	542/NA	290 CFM/ton	CFM	625	603	582	559	533
2 tons †	350 CFM/ton	734/815	730/698	717/541	705/NA	684/NA	350 CFM/ton	CFM	731	722	710	696	677
	400 † CFM/ton	822/898	824/792	817/657	811/NA	797/NA	400 (a) CFM/ton	CFM	817	815	811	801	788
	450 CFM/ton	910/982	916/884	916/763	914/610	904/NA	450 CFM/ton	CFM	902	907	908	904	895
	290 CFM/ton	755/860	753/749	742/606	732/397	712/NA	290 CFM/ton	CFM	753	745	735	723	706
	350 CFM/ton	887/985	893/887	891/767	888/614	876/NA	350 CFM/ton	CFM	881	884	884	879	868
2.5 tons	400 CFM/ton	998/1094	1010/1003	1017/895	1018/765	1008/NA	400 CFM/ton	CFM	989	1001	1008	1008	1000
	450 CFM/ton	1116/1212	1135/1126	1147/1027	1148/911	1134/NA	450 CFM/ton	CFM	1104	1124	1136	1139	1128
	290 CFM/ton	883/981	888/882	887/762	881/608	870/NA	290 CFM/ton	CFM	877	880	879	874	863
	350 CFM/ton	1043/1140	1059/1051	1068/947	1069/823	1059/NA	350 CFM/ton	CFM	1034	1049	1058	1061	1053
	400 CFM/ton	1190/1304	1214/1221	1226/1126	1223/1016	1201/886	400 CFM/ton	CFM	1177	1201	1215	1215	1198
3 tons	450 CFM/ton	1355/1471	1376/1391	1375/1302	1353/1201	1296/1086	450 CFM/ton	CFM	1338	1363	1368	1350	1314
	290 CFM/ton	79/101	124/122	169/136	214/140	257/NA	290 CFM/ton	CFM	74	118	164	208	252
	350 CFM/ton	120/150	177/174	233/190	288/197	339/NA	350 CFM/ton	CFM	112	168	224	279	330
	400 CFM/ton	170/203	238/231	304/251	364/261	414/261	400 CFM/ton	CFM	157	224	291	352	403
	450 CFM/ton	241/282	318/311	386/333	441/345	472/345	450 CFM/ton	CFM	221	299	369	427	472

- † Factory Setting
- Status LED will blink once per 100 CFM requested. In torque mode, actual airflow may be lower.
- Torque mode will reduce airflow when static is above approximately 0.35" water column.
- All heating modes default to Constant CFM.
- Cooling airflow values are with wet coil, no filter

TAM9A0B30 Minimum Heating Airflow Settings					
MODEL NO.	BAYEAC04BK1 BAYEAC04LG1 BAYEAC05BK1 BAYEAC05LG1	BAYEAC08BK1 BAYEAC08LG1	BAYEAC10BK1 BAYEAC10LG1	BAYEAC15BK1 BAYEAC15LG3	BAYEABC20BK1
TAM9A0B30	723/808	723/1020	765/1020	680/808	765/1063
WITHOUT HEAT PUMP / WITH HP — SEE AIR HANDLER NAMEPLATE					
850/1105					

(a) Factory heating default setting is 430 CFM/ton

TAM9 Air Flow Performance Tables

TAM9A0C36 AIRFLOW PERFORMANCE CONSTANT CFM MODE / CONSTANT TORQUE MODE														
OUTDOOR MULTIPLIER (TONS)	COOLING AIRFLOW SETTING	AIRFLOW POWER	EXTERNAL STATIC PRESSURE (Constant CFM / Constant Torque)				HEATING AIRFLOW SETTING	AIRFLOW POWER	EXTERNAL STATIC PRESSURE					
			0.1	0.3	0.5	0.7			0.9	0.1	0.3	0.5	0.7	0.9
2 tons	290 CFM/ton	CFM Watts	605/747 31/48	573/565 59/58	553/306 88/62	548/NA 120/NA	546/NA 153/NA	290 CFM/ton	CFM Watts	606 31	574 58	557 87	551 119	549 152
	370 CFM/ton	CFM Watts	755/880 50/70	745/738 85/85	737/575 121/93	738/367 160/97	735/NA 197/NA	350 CFM/ton	CFM Watts	720 43	705 77	695 111	694 148	691 184
	400 CFM/ton	CFM Watts	810/929 58/80	804/797 97/96	800/650 136/106	802/478 176/111	802/231 216/120	400 CFM/ton	CFM Watts	810 56	805 95	800 134	803 174	802 214
	450 CFM/ton	CFM Watts	900/1011 75/98	900/893 118/117	902/764 162/129	905/624 207/136	906/462 251/140	450 CFM/ton	CFM Watts	900 72	900 115	903 159	906 204	907 248
	290 CFM/ton	CFM Watts	742/891 48/72	729/752 82/87	722/592 118/96	721/394 155/99	720/NA 193/NA	290 CFM/ton	CFM Watts	742 46	731 81	722 117	722 154	720 191
	370 CFM/ton	CFM Watts	922/1055 80/109	923/942 124/128	927/820 170/142	930/690 215/150	931/546 260/154	350 CFM/ton	CFM Watts	877 68	877 110	876 152	880 196	880 239
2.5 tons	400 CFM/ton	CFM Watts	989/1118 95/127	995/1012 143/148	1002/899 193/163	1008/779 242/173	1010/652 290/177	400 CFM/ton	CFM Watts	989 90	995 139	1000 188	1008 258	1008 285
	450 CFM/ton	CFM Watts	1103/1228 125/162	1117/1131 181/185	1129/1028 238/203	1137/921 294/215	1137/809 346/221	450 CFM/ton	CFM Watts	1102 119	1116 175	1127 231	1137 288	1138 340
	290 CFM/ton	CFM Watts	872/1009 70/97	871/890 111/116	871/761 154/128	874/620 197/135	874/457 240/139	290 CFM/ton	CFM Watts	871 67	872 109	871 151	874 195	875 237
	370 † CFM/ton	CFM Watts	1089/1214 121/157	1102/1116 176/180	1114/1013 232/198	1121/905 287/209	1122/791 339/215	350 CFM/ton	CFM Watts	1033 101	1043 152	1051 204	1059 257	1061 307
	400 CFM/ton	CFM Watts	1175/1298 147/188	1193/1205 208/212	1208/1107 270/231	1215/1006 329/244	1211/899 382/251	400 (a) CFM/ton	CFM Watts	1171 139	1191 200	1205 262	1215 322	1212 376
	450 CFM/ton	CFM Watts	1329/1447 204/253	1353/1361 276/279	1366/1270 345/299	1363/1176 406/313	1343/1077 456/321	450 CFM/ton	CFM Watts	1324 192	1349 264	1364 334	1364 396	1347 448
3.5 tons	290 CFM/ton	CFM Watts	1002/1131 98/130	1009/1026 147/152	1017/914 198/167	1023/797 248/177	1024/671 296/182	290 CFM/ton	CFM Watts	997 92	1010 143	1016 197	1022 248	1027 293
	370 CFM/ton	CFM Watts	1270/1391 181/227	1293/1302 249/252	1308/1210 316/272	1311/1113 377/286	1297/1012 429/293	350 CFM/ton	CFM Watts	1196 146	1217 210	1231 272	1241 334	1234 387
	400 CFM/ton	CFM Watts	1383/1499 227/278	1407/1414 303/305	1416/1325 372/325	1406/1233 431/340	1380/1136 478/348	400 CFM/ton	CFM Watts	1379 214	1404 289	1415 360	1330 378	1390 473
	450 CFM/ton	CFM Watts	1579/1669 326/375	1583/1587 402/402	1567/1502 464/423	1474/1413 475/437	1357/1320 468/444	450 CFM/ton	CFM Watts	1499 268	1508 342	1586 460	1504 478	1390 472
	<ul style="list-style-type: none"> † Factory Setting Status LED will blink once per 100 CFM requested. In torque mode, actual airflow may be lower. Torque mode will reduce airflow when static is above approximately 0.35" water column. All heating modes default to Constant CFM. Cooling airflow values are with wet coil, no filter 													
	TAM9A0C36 Minimum Heating Airflow Settings													
MODEL NO.	BAYEAC04BK1 BAYEAC04LG1 BAYEAC05BK1 BAYEAC05LG1	BAYEAC08BK1 BAYEAC08LG1	BAYEAC10BK1 BAYEAC10LG1	BAYEAC10LG3	BAYEABC15BK1	BAYEABC15LG3	BAYEABC20BK1							
TAM9A0C36	876/979	876/1236	927/1236	824/979	927/1288	1030/1339	1236/1442							

(a) Factory heating default setting is 420 CFM/ton

TAM9 Air Flow Performance Tables

OUTDOOR MULTIPLIER (TONS)	TAM9A0C42 AIRFLOW PERFORMANCE										CONSTANT CFM MODE / CONSTANT TORQUE MODE									
	EXTERNAL STATIC PRESSURE (Constant CFM / Constant Torque)					HEATING AIRFLOW SETTING					AIRFLOW POWER					EXTERNAL STATIC PRESSURE				
	0.1	0.3	0.5	0.7	0.9	290 CFM/ton	350 CFM/ton	400 CFM/ton	450 CFM/ton	290 Watts	350 Watts	400 Watts	450 Watts	0.1	0.3	0.5	0.7	0.9		
2.5 tons	747/905	743/764	742/591	741/342	739/NA	290	350	400	450	CFM	CFM	CFM	CFM	744	741	740	738	734		
	48/77	87/94	127/102	168/106	207/NA	CFM/ton	CFM/ton	CFM/ton	CFM/ton	Watts	Watts	Watts	Watts	51	90	130	170	209		
	937/1072	942/956	946/823	947/655	944/458	370	400	450	350	CFM	CFM	CFM	CFM	889	892	894	894	890		
	80/118	129/139	179/151	227/155	273/155	CFM/ton	CFM/ton	CFM/ton	CFM/ton	Watts	Watts	Watts	Watts	76	123	169	215	259		
	1006/1136	1014/1027	1020/903	1022/760	1019/586	400	450	500	400	CFM	CFM	CFM	CFM	1006	1016	1018	1019	1016		
	95/138	148/159	201/173	253/178	302/177	CFM/ton	CFM/ton	CFM/ton	CFM/ton	Watts	Watts	Watts	Watts	103	156	209	160	308		
	1122/1247	1135/1146	1143/1035	1146/911	1142/768	450	500	550	450	CFM	CFM	CFM	CFM	1124	1135	1142	1144	1140		
	125/176	185/200	245/216	303/224	357/223	CFM/ton	CFM/ton	CFM/ton	CFM/ton	Watts	Watts	Watts	Watts	136	196	256	313	366		
	885/1026	889/904	891/763	892/590	889/341	290	350	400	290	CFM	CFM	CFM	CFM	884	887	889	889	885		
	70/106	116/125	163/136	209/139	254/143	CFM/ton	CFM/ton	CFM/ton	CFM/ton	Watts	Watts	Watts	Watts	75	121	168	214	257		
3 tons	1108/1233	1120/1132	1128/1019	1131/893	1128/747	370	400	450	350	CFM	CFM	CFM	CFM	1053	1062	1067	1069	1066		
	121/171	181/195	240/210	297/218	350/217	CFM/ton	CFM/ton	CFM/ton	CFM/ton	Watts	Watts	Watts	Watts	115	171	227	280	330		
	1194/1316	1208/1220	1218/1115	1221/999	1215/868	400	450	500	400	CFM	CFM	CFM	CFM	1196	1209	1218	1219	1212		
	147/204	212/229	276/246	337/255	393/256	CFM/ton	CFM/ton	CFM/ton	CFM/ton	Watts	Watts	Watts	Watts	160	225	289	349	403		
	1343/1463	1361/1374	1371/1279	1368/1175	1352/1061	450	500	550	450	CFM	CFM	CFM	CFM	1347	1363	1371	1366	1342		
	200/272	275/300	348/320	413/331	469/334	CFM/ton	CFM/ton	CFM/ton	CFM/ton	Watts	Watts	Watts	Watts	220	295	367	430	480		
	1020/1149	1028/1041	1034/919	1037/779	1034/609	290	350	400	290	CFM	CFM	CFM	CFM	1020	1028	1033	1173	1031		
	99/142	152/164	206/178	259/183	308/182	CFM/ton	CFM/ton	CFM/ton	CFM/ton	Watts	Watts	Watts	Watts	107	160	214	327	315		
	1287/1408	1304/1317	1314/1218	1315/1110	1304/981	370	400	450	350	CFM	CFM	CFM	CFM	1220	1234	1243	1244	1236		
	179/245	250/272	320/291	384/301	441/303	CFM/ton	CFM/ton	CFM/ton	CFM/ton	Watts	Watts	Watts	Watts	169	236	301	362	417		
3.5 tons †	1395/1514	1413/1427	1421/1334	1415/1233	1369/1124	400	450	500	400	CFM	CFM	CFM	CFM	1440	1416	1421	1411	1355		
	221/299	300/328	374/348	440/361	480/364	CFM/ton	CFM/ton	CFM/ton	CFM/ton	Watts	Watts	Watts	Watts	244	322	395	458	475		
	1584/1687	1593/1605	1576/1518	1474/1425	1350/1326	450	500	550	450	CFM	CFM	CFM	CFM	1589	1592	1545	1434	1315		
	313/405	399/435	467/458	477/472	468/477	CFM/ton	CFM/ton	CFM/ton	CFM/ton	Watts	Watts	Watts	Watts	347	428	474	473	463		
	1156/1302	1169/1205	1178/1098	1181/981	1174/848	290	350	400	290	CFM	CFM	CFM	CFM	1157	1169	1177	1179	1174		
	135/197	197/222	259/239	319/248	383/249	CFM/ton	CFM/ton	CFM/ton	CFM/ton	Watts	Watts	Watts	Watts	147	209	271	330	383		
	1487/1618	1500/1534	1496/1445	1445/1350	1319/1248	370	400	450	350	CFM	CFM	CFM	CFM	1400	1416	1421	1411	1335		
	288/359	369/389	441/411	481/425	470/429	CFM/ton	CFM/ton	CFM/ton	CFM/ton	Watts	Watts	Watts	Watts	244	322	395	458	475		
	1616/1728	1614/1646	1543/1543	1423/1423	1301/1301	400	450	500	400	CFM	CFM	CFM	CFM	1615	1615	1545	1431	1313		
	363/433	443/464	475/475	472/472	463/463	CFM/ton	CFM/ton	CFM/ton	CFM/ton	Watts	Watts	Watts	Watts	363	444	474	471	462		
4 tons	1711/1711	1621/1621	1514/1514	1393/1393	1273/1273	450	500	550	450	CFM	CFM	CFM	CFM	1716	1629	1528	1411	1297		
	432/432	456/456	465/465	460/460	453/453	CFM/ton	CFM/ton	CFM/ton	CFM/ton	Watts	Watts	Watts	Watts	430	453	462	458	452		
	<ul style="list-style-type: none"> † Factory Setting Status LED will blink once per 100 CFM requested. In torque mode, actual airflow may be lower. Torque mode will reduce airflow when static is above approximately 0.35" water column. All heating modes default to Constant CFM. Cooling airflow values are with wet coil, no filter 																			
	TAM9A0C42 Minimum Heating Airflow Settings																			
	MODEL NO.	BAYEAC04BK1 BAYEAC04LG1 BAYEAC05BK1 BAYEAC05LG1	BAYEAC08BK1 BAYEAC08LG1	BAYEAC10BK1 BAYEAC10LG1	BAYEAC10LG3	BAYEABC15BK1	BAYEABC15LG3	BAYEABC20BK1												
	TAM9A0C42	978/1093	978/1380	1035/1380	920/1093	1035/1438	1150/1495	1380/1610												
	WITHOUT HEAT PUMP / WITH HP — SEE AIR HANDLER NAMEPLATE																			

TAM9 Air Flow Performance Tables

TAM9A0C48 AIRFLOW PERFORMANCE CONSTANT CFM MODE / CONSTANT TORQUE MODE												
OUTDOOR MULTIPLIER (TONS)	COOLING AIRFLOW SETTING	AIRFLOW POWER	EXTERNAL STATIC PRESSURE (Constant CFM / Constant Torque)			HEATING AIRFLOW SETTING	AIRFLOW POWER	EXTERNAL STATIC PRESSURE				
			0.1	0.3	0.5			0.7	0.9	0.1	0.3	0.5
3 tons	290 CFM/ton	CFM Watts	894 / 1018 69 / 91	900 / 897 114 / 114	896 / 767 157 / 130	886 / 622 195 / 137	871 / 445 229 / 136	290 CFM/ton	CFM Watts	893 / 900 72 / 118	883 / 853 197 / 230	864 / 834 240 / 260
	350 CFM/ton	CFM Watts	1067 / 1180 106 / 132	1073 / 1078 158 / 160	1072 / 972 208 / 180	1065 / 859 252 / 192	1053 / 738 292 / 194	350 CFM/ton	CFM Watts	1068 / 1073 112 / 164	1070 / 1062 257 / 295	1049 / 1019 295 / 330
	400 CFM/ton	CFM Watts	1205 / 1314 145 / 176	1212 / 1222 203 / 206	1213 / 1128 259 / 229	1208 / 1029 309 / 244	1199 / 926 354 / 249	400 CFM/ton	CFM Watts	1207 / 1212 154 / 212	1212 / 1206 266 / 315	1196 / 1166 359 / 408
	450 CFM/ton	CFM Watts	1343 / 1451 193 / 232	1352 / 1367 259 / 264	1353 / 1280 320 / 289	1353 / 1190 377 / 305	1346 / 1098 427 / 313	450 CFM/ton	CFM Watts	1344 / 1352 206 / 270	1354 / 1342 387 / 436	1344 / 1314 436 / 485
	290 CFM/ton	CFM Watts	1034 / 1149 98 / 123	1041 / 1044 149 / 150	1038 / 934 197 / 170	1031 / 817 240 / 181	1018 / 690 279 / 182	290 CFM/ton	CFM Watts	1034 / 1040 103 / 154	1037 / 1028 244 / 281	1014 / 984 281 / 320
	350 CFM/ton	CFM Watts	1228 / 1336 152 / 185	1235 / 1246 212 / 215	1236 / 1153 268 / 238	1232 / 1056 319 / 253	1224 / 955 365 / 259	350 CFM/ton	CFM Watts	1229 / 1235 162 / 221	1236 / 1230 276 / 326	1220 / 1190 326 / 371
	400 CFM/ton	CFM Watts	1389 / 1498 212 / 253	1399 / 1415 280 / 286	1403 / 1331 343 / 311	1401 / 1244 402 / 328	1395 / 1154 455 / 336	400 CFM/ton	CFM Watts	1392 / 1400 226 / 293	1403 / 1400 356 / 413	1394 / 1364 465 / 514
	450 CFM/ton	CFM Watts	1558 / 1669 290 / 343	1570 / 1592 367 / 377	1575 / 1514 439 / 404	1575 / 1434 505 / 422	1568 / 1351 563 / 432	450 CFM/ton	CFM Watts	1561 / 1572 310 / 386	1576 / 1574 457 / 521	1567 / 1537 521 / 577
	290 CFM/ton	CFM Watts	1168 / 1298 133 / 170	1175 / 1205 191 / 200	1175 / 1109 244 / 223	1170 / 1010 293 / 237	1160 / 905 336 / 242	290 CFM/ton	CFM Watts	1168 / 1176 141 / 198	1174 / 1168 251 / 299	1157 / 1127 341 / 390
	350 † CFM/ton	CFM Watts	1389 / 1517 212 / 262	1399 / 1436 280 / 295	1403 / 1352 343 / 321	1401 / 1266 402 / 338	1395 / 1177 455 / 346	350 CFM/ton	CFM Watts	1392 / 1400 226 / 293	1403 / 1400 356 / 413	1394 / 1364 465 / 514
400 CFM/ton	CFM Watts	1583 / 1714 303 / 370	1595 / 1639 382 / 546	1601 / 1562 455 / 431	1600 / 1483 521 / 450	1593 / 1401 580 / 459	400 † CFM/ton	CFM Watts	1586 / 1597 325 / 402	1601 / 1599 474 / 538	1591 / 1561 538 / 602	
450 CFM/ton	CFM Watts	1790 / 1918 429 / 511	1800 / 184 851.5 / 546	1808 / 1775 594 / 573	1793 / 1701 663 / 592	1698 / 1625 660 / 601	450 CFM/ton	CFM Watts	1794 / 1801 459 / 544	1800 / 1766 620 / 665	1667 / 1637 655 / 704	
290 CFM/ton	CFM Watts	1301 / 1429 177 / 222	1310 / 1344 241 / 253	1312 / 1256 300 / 278	1309 / 1165 355 / 294	1302 / 1071 404 / 302	290 CFM/ton	CFM Watts	1302 / 1310 189 / 252	1311 / 1309 310 / 355	1301 / 1271 355 / 403	
350 CFM/ton	CFM Watts	1558 / 1688 290 / 354	1570 / 1613 367 / 389	1575 / 1535 439 / 415	1575 / 1455 505 / 434	1568 / 1373 563 / 444	350 CFM/ton	CFM Watts	1557 / 1570 290 / 367	1575 / 1575 439 / 505	1569 / 1539 563 / 612	
400 CFM/ton	CFM Watts	1790 / 1918 429 / 511	1800 / 1848 515 / 546	1801 / 1775 594 / 573	1793 / 1701 663 / 592	1698 / 1625 660 / 601	400 CFM/ton	CFM Watts	1789 / 1799 428 / 515	1801 / 1794 594 / 663	1701 / 1671 659 / 708	
450 CFM/ton	CFM Watts	2018 / 2018 605 / 605	1973 / 1973 656 / 656	1857 / 1857 645 / 645	1749 / 1749 637 / 637	1651 / 1651 631 / 631	450 CFM/ton	CFM Watts	2018 / 1975 605 / 656	1863 / 1863 643 / 634	1660 / 1630 634 / 628	
<ul style="list-style-type: none"> † Factory Setting ** Not an actual OD size Status LED will blink once per 100 CFM requested. In torque mode, actual airflow may be lower. Torque mode will reduce airflow when static is above approximately 0.4" water column. If the air handler is applied in downflow or horizontal configurations, the airflow should not exceed 2000 CFM. Airflow above 2000 CFM could result in water blow-off. All heating modes default to Constant CFM. Cooling airflow values are with wet coil, no filter 												
TAM9A0C48 Minimum Heating Airflow Settings												
MODEL NO.	BAYEAC04BK1 BAYEAC04LG1 BAYEAC05BK1 BAYEAC05LG1	BAYEAC08BK1 BAYEAC08LG1	BAYEAC10BK1 BAYEAC10LG1	BAYEAC10LG3	BAYEABC15BK1	BAYEACB15LG3	BAYEABC25BK1					
TAM9A0C48	1063 / 1188	1063 / 1500	1125 / 1500	1000 / 1188	1125 / 1563	1250 / 1625	1500 / 1750	WITHOUT HEAT PUMP / WITH HP — SEE AIR HANDLER NAMEPLATE				

TAM9 Air Flow Performance Tables

OUTDOOR MULTIPLIER (TONS)	TAM9A0C60 AIRFLOW PERFORMANCE										CONSTANT CFM MODE / CONSTANT TORQUE MODE												
	EXTERNAL STATIC PRESSURE (Constant CFM / Constant Torque)					HEATING AIRFLOW SETTING	AIRFLOW POWER	EXTERNAL STATIC PRESSURE															
	0.1	0.3	0.5	0.7	0.9			0.1	0.3	0.5	0.7	0.9											
3.5 tons	COOLING AIRFLOW SETTING	290 CFM/ton	290 CFM/ton	290 CFM/ton	290 CFM/ton	290 CFM/ton	290 CFM/ton	290 CFM/ton	290 CFM/ton	290 CFM/ton	HEATING AIRFLOW SETTING	290 CFM/ton	350 CFM/ton	400 CFM/ton	450 CFM/ton	290 CFM/ton	350 CFM/ton	400 CFM/ton	450 CFM/ton	290 CFM/ton	350 CFM/ton	400 CFM/ton	450 CFM/ton
	AIRFLOW POWER	1040/1151 Watts	1068/1056 Watts	1075/941 Watts	1066/799 Watts	1046/607 Watts	1039 Watts	1065 Watts	1071 Watts	1063 Watts	AIRFLOW POWER	1039 Watts	1247 Watts	1407 Watts	1564 Watts	1039 Watts	1247 Watts	1407 Watts	1564 Watts	1039 Watts	1247 Watts	1407 Watts	1564 Watts
		94/119	151/148	203/168	247/175	283/165	95	151	203	247		95	151	203	247	95	151	203	247	95	151	203	247
		1312/1343	1332/1264	1336/1174	1329/1068	1314/945	1247	1266	1270	1263		1247	1314/945	1314/945	1314/945	1247	1266	1270	1263	1247	1266	1270	1263
		171/178	236/210	296/235	349/250	392/251	150	213	270	321		150	213	270	321	150	213	270	321	150	213	270	321
		1408/1496	1425/1426	1429/1346	1423/1256	1410/1154	1407	1423	1426	1421		1407	1423	1426	1421	1407	1423	1426	1421	1407	1423	1426	1421
		206/238	274/273	337/301	393/319	440/325	206	274	337	392		206	274	337	392	206	274	337	392	206	274	337	392
		1565/1650	1579/1585	1584/1512	1580/1432	1569/1343	1564	1578	1582	1578		1564	1578	1582	1578	1564	1578	1582	1578	1564	1578	1582	1578
		274/312	348/348	416/378	477/398	529/407	274	348	416	476		274	348	416	476	274	348	416	476	274	348	416	476
		1186/1304	1208/1223	1213/1128	1206/1018	1189/887	1185	1206	1210	1203		1185	1206	1210	1203	1185	1206	1210	1203	1185	1206	1210	1203
4 tons	COOLING AIRFLOW SETTING	370 CFM/ton	370 CFM/ton	370 CFM/ton	370 CFM/ton	370 CFM/ton	370 CFM/ton	370 CFM/ton	370 CFM/ton	370 CFM/ton	HEATING AIRFLOW SETTING	350 CFM/ton	400 CFM/ton	450 CFM/ton	350 CFM/ton	400 CFM/ton	450 CFM/ton	350 CFM/ton	400 CFM/ton	450 CFM/ton	350 CFM/ton	400 CFM/ton	450 CFM/ton
	AIRFLOW POWER	1480/1514	1495/1444	1499/1365	1495/1277	1482/1177	1407	1423	1426	1421		1407	1423	1426	1421	1407	1423	1426	1421	1407	1423	1426	1421
		235/245	306/280	372/308	430/327	479/334	206	274	337	392		206	274	337	392	206	274	337	392	206	274	337	392
		1587/1689	1602/1625	1606/1554	1602/1475	1592/1399	1587	1600	1604	1601		1587	1600	1604	1601	1587	1600	1604	1601	1587	1600	1604	1601
		285/332	360/369	429/399	490/420	543/430	285	360	428	490		285	360	428	490	285	360	428	490	285	360	428	490
		1770/1873	1784/1813	1789/1747	1788/1675	1782/1597	1770	1783	1788	1788		1770	1783	1788	1788	1770	1783	1788	1788	1770	1783	1788	1788
		386/443	468/481	543/512	612/534	671/546	385	467	543	611		385	467	543	611	385	467	543	611	385	467	543	611
		1322/1431	1340/1358	1345/1274	1338/1179	1323/1069	1321	1338	1342	1336		1321	1338	1342	1336	1321	1338	1342	1336	1321	1338	1342	1336
		174/211	240/245	300/271	353/288	397/292	174	240	300	352		174	240	300	352	174	240	300	352	174	240	300	352
		1646/1667	1660/1602	1665/1530	1662/1451	1653/1363	1564	1578	1582	1578		1564	1578	1582	1578	1564	1578	1582	1578	1564	1578	1582	1578
4.5 tons **†	COOLING AIRFLOW SETTING	400 CFM/ton	400 CFM/ton	400 CFM/ton	400 CFM/ton	400 CFM/ton	400 CFM/ton	400 CFM/ton	400 CFM/ton	400 CFM/ton	HEATING AIRFLOW SETTING	400 CFM/ton	450 CFM/ton	500 CFM/ton	400 CFM/ton	450 CFM/ton	500 CFM/ton	400 CFM/ton	450 CFM/ton	500 CFM/ton	400 CFM/ton	450 CFM/ton	500 CFM/ton
	AIRFLOW POWER	1770/1873	1784/1813	1789/1747	1788/1675	1782/1597	1770	1783	1788	1788		1770	1783	1788	1788	1770	1783	1788	1788	1770	1783	1788	1788
		386/443	468/481	543/512	612/534	671/546	385	467	543	611		385	467	543	611	385	467	543	611	385	467	543	611
		1989/2099	2004/2042	2012/1980	2013/1913	2009/1842	1989	2003	2011	2014		1989	2003	2011	2014	1989	2003	2011	2014	1989	2003	2011	2014
		535/612	627/650	712/681	788/703	855/716	534	626	711	788		534	626	711	788	534	626	711	788	534	626	711	788
		1452/1557	1469/1489	1473/1413	1468/1327	1455/1231	1452	1467	1471	1466		1452	1467	1471	1466	1452	1467	1471	1466	1452	1467	1471	1466
		224/265	294/301	358/329	415/348	463/356	224	294	358	415		224	294	358	415	224	294	358	415	224	294	358	415
		1817/1826	1831/1765	1837/1698	1837/1624	1831/1544	1723	1736	1741	1740		1723	1736	1741	1740	1723	1736	1741	1740	1723	1736	1741	1740
		415/451	499/451	576/481	647/503	708/515	357	437	511	578		357	437	511	578	357	437	511	578	357	437	511	578
		1964/2073	1978/2015	1986/1953	1987/1886	1983/1814	1964	1978	1985	1988		1964	1978	1985	1988	1964	1978	1985	1988	1964	1978	1985	1988
	516/590	607/629	690/660	766/682	832/695	515	606	690	766		515	606	690	766	515	606	690	766	515	606	690	766	
	2231/2347	2245/2292	2252/2233	2252/2171	2185/2104	2232	2245	2252	2252		2232	2245	2252	2252	2232	2245	2252	2252	2232	2245	2252	2252	
	741/842	842/879	934/908	1015/930	1024/941	741	842	934	1016		741	842	934	1016	741	842	934	1016	741	842	934	1016	

† Factory Setting
 ** Not an actual OD size
 Status LED will blink once per 100 CFM requested. In torque mode, actual airflow may be lower.
 Torque mode will reduce airflow when static is above approximately 0.4" water column.

TAM9A0C60 MINIMUM HEATING AIRFLOW CFM — HEATER MATRIX

MODEL NO.	BAYEAC08BK1	BAYEAC10BK1	BAYEAC15BK1	BAYEAC20BK1	BAYEAC25BK1
	BAYEAC04LG1	BAYEAC05BK1	BAYEAC10LG3	BAYEAC15LG3	BAYEAC20BK1
	BAYEAC05LG1	BAYEAC10LG1	BAYEAC15LG3	BAYEAC20BK1	BAYEAC25BK1
TAM9A0C60	1063 / 1188	1125 / 1500	1000 / 1188	1250 / 1625	1500 / 1750
WITHOUT HEAT PUMP / WITH HP — SEE AIR HANDLER NAMEPLATE					

HEATER ATTRIBUTE DATA

Note: Heater size must be set in Configuration Menu.

TAM9A0A24V21DB											
Heater Model No.	No. of Circuits	240 Volt					208 Volt				
		Capacity		Heater Amps per Circuit	Minimum Circuit Ampacity	Maximum Overload Protection	Capacity		Heater Amps per Circuit	Minimum Circuit Ampacity	Maximum Overload Protection
		kW	BTUH				kW	BTUH			
No Heater	0	-	-	4.1 **	5	15	-	-	4.1 **	5	15
BAYEAAC04++1	1	3.84	13100	16.0	25	25	2.88	9800	13.8	22	25
BAYEAAC05++1	1	4.80	16400	20.0	30	30	3.60	12300	17.3	27	30
BAYEAAC08++1	1	7.68	26200	32.0	45	45	5.76	19700	27.7	40	40
BAYEAAC10++1 (a)	1	9.60	32800	40.0	55	60	7.20	24600	34.6	48	50
BAYEAAC10LG3	1-3 PH	9.60	32800	23.1	34	35	7.20	24600	20.0	30	30

Note: ** Motor Amps

(a) Heater not qualified for 208V when installed in horizontal left position without Heat Pump

TAM9A0B30V31DB											
Heater Model No.	No. of Circuits	240 Volt					208 Volt				
		Capacity		Heater Amps per Circuit	Minimum Circuit Ampacity	Maximum Overload Protection	Capacity		Heater Amps per Circuit	Minimum Circuit Ampacity	Maximum Overload Protection
		kW	BTUH				kW	BTUH			
No Heater	0	-	-	4.1 **	5	15	-	-	4.1 **	5	15
BAYEAAC04++1	1	3.84	13100	16.0	25	25	2.88	9800	13.8	22	25
BAYEAAC05++1	1	4.80	16400	20.0	30	30	3.60	12300	17.3	27	30
BAYEAAC08++1	1	7.68	26200	32.0	45	45	5.76	19700	27.7	40	40
BAYEAAC10++1	1	9.60	32800	40.0	55	60	7.20	24600	34.6	48	50
BAYEAAC10LG3	1-3 PH	9.60	32800	23.1	34	35	7.20	24600	20.0	30	30
BAYEABC15LG3	1-3 PH	14.4-0	42000	34.6	48	50	10.80	36900	30.0	43	45
BAYEABC15BK1 - Circuit 1 (a)	2	9.60	32800	40.0	55	60	7.20	24600	34.6	48	50
BAYEABC15BK1 - Circuit 2		4.80	16400	20.0	25	25	3.60	12300	17.3	22	25

Note: ** Motor Amps

(a) MCA and MOP for circuit 1 contains the motor amps

HEATER ATTRIBUTE DATA

TAM9A0C36V31DB											
Heater Model No.	No. of Circuits	240 Volt					208 Volt				
		Capacity		Heater Amps per Circuit	Minimum Circuit Ampacity	Maximum Overload Protection	Capacity		Heater Amps per Circuit	Minimum Circuit Ampacity	Maximum Overload Protection
		kW	BTUH				kW	BTUH			
No Heater	0	-	-	4.1 **	5	15	-	-	4.1 **	5	15
BAYEAAC04++1	1	3.84	13100	16.0	25	25	2.88	9800	13.8	22	25
BAYEAAC05++1	1	4.80	16400	20.0	30	30	3.60	12300	17.3	27	30
BAYEAAC08++1	1	7.68	26200	32.0	45	45	5.76	19700	27.7	40	40
BAYEAAC10++1	1	9.60	32800	40.0	55	60	7.20	24600	34.6	48	50
BAYEAAC10LG3	1-3 PH	9.60	32800	23.1	34	35	7.20	24600	20.0	30	30
BAYEABC15LG3	1-3 PH	14.40	42000	34.6	48	50	10.80	36900	30.0	43	45
BAYEABC15BK1 - Circuit 1 (a) BAYEABC15BK1 - Circuit 2	2	9.60	32800	40.0	55	60	7.20	24600	34.6	48	50
		4.80	16400	20.0	25	25	3.60	12300	17.3	22	25
BAYEABC20BK1 - Circuit 1 (a) BAYEABC20BK1 - Circuit 2	2	9.60	32800	40.0	55	60	7.20	24600	34.6	48	50
		9.60	32800	40.0	50	50	7.20	24600	34.6	43	45

Note: ** Motor Amps

(a) MCA and MOP for circuit 1 contains the motor amps

TAM9A0C42V41DB											
Heater Model No.	No. of Circuits	240 Volt					208 Volt				
		Capacity		Heater Amps per Circuit	Minimum Circuit Ampacity	Maximum Overload Protection	Capacity		Heater Amps per Circuit	Minimum Circuit Ampacity	Maximum Overload Protection
		kW	BTUH				kW	BTUH			
No Heater	0	-	-	4.1 **	5	15	-	-	4.1 **	5	15
BAYEAAC04++1	1	3.84	13100	16.0	25	25	2.88	9800	13.8	22	25
BAYEAAC05++1	1	4.80	16400	20.0	30	30	3.60	12300	17.3	27	30
BAYEAAC08++1	1	7.68	26200	32.0	45	45	5.76	19700	27.7	40	40
BAYEAAC10++1	1	9.60	32800	40.0	55	60	7.20	24600	34.6	48	50
BAYEAAC10LG3	1-3 PH	9.60	32800	23.1	34	35	7.20	24600	20.0	30	30
BAYEABC15LG3	1-3 PH	14.40	42000	34.6	48	50	10.80	36900	30.0	43	45
BAYEABC15BK1 - Circuit 1 (a) BAYEABC15BK1 - Circuit 2	2	9.60	32800	40.0	55	60	7.20	24600	34.6	48	50
		4.80	16400	20.0	25	25	3.60	12300	17.3	22	25
BAYEABC20BK1 - Circuit 1 (a) BAYEABC20BK1 - Circuit 2	2	9.60	32800	40.0	55	60	7.20	24600	34.6	48	50
		9.60	32800	40.0	50	50	7.20	24600	34.6	43	45

Note: ** Motor Amps

(a) MCA and MOP for circuit 1 contains the motor amps

HEATER ATTRIBUTE DATA

TAM9A0C48V41DB											
Heater Model No.	No. of Circuits	240 Volt					208 Volt				
		Capacity		Heater Amps per Circuit	Minimum Circuit Ampacity	Maximum Overload Protection	Capacity		Heater Amps per Circuit	Minimum Circuit Ampacity	Maximum Overload Protection
		kW	BTUH				kW	BTUH			
No Heater	0	-	-	6.1 **	8	15	-	-	6.1 **	8	15
BAYEAAC04++1	1	3.84	13100	16.0	28	30	2.88	9800	13.8	25	25
BAYEAAC05++1	1	4.80	16400	20.0	33	35	3.60	12300	17.3	29	30
BAYEAAC08++1	1	7.68	26200	32.0	48	50	5.76	19700	27.7	42	45
BAYEAAC10++1	1	9.60	32800	40.0	58	60	7.20	24600	34.6	51	60
BAYEAAC10LG3	1-3 PH	9.60	32800	23.1	37	40	7.20	24600	20.0	33	35
BAYEABC15LG3	1-3 PH	14.40	42000	34.6	51	60	10.80	36900	30.0	45	45
BAYEABC15BK1 - Circuit 1 (a) BAYEABC15BK1 - Circuit 2	2	9.60	32800	40.0	58	60	7.20	24600	34.6	51	60
		4.80	16400	20.0	25	25	3.60	12300	17.3	22	25
BAYEABC20BK1 - Circuit 1 (a) BAYEABC20BK1 - Circuit 2	2	9.60	32800	40.0	58	60	7.20	24600	34.6	51	60
		9.60	32800	40.0	50	50	7.20	24600	34.6	43	45
BAYEACC25BK1 — Circuit 1 (a) BAYEACC25BK1 — Circuit 2 BAYEACC25BK1 — Circuit 3	3	9.60	32800	40.0	58	60	7.20	24600	34.6	51	60
		9.60	32800	40.0	50	50	7.20	24600	34.6	43	45
		4.80	16400	20.0	25	25	3.60	12300	17.3	22	25

Note: ** Motor Amps

(a) MCA and MOP for circuit 1 contains the motor amps

TAM9A0C60V51DB											
Heater Model No.	No. of Circuits	240 Volt					208 Volt				
		Capacity		Heater Amps per Circuit	Minimum Circuit Ampacity	Maximum Overload Protection	Capacity		Heater Amps per Circuit	Minimum Circuit Ampacity	Maximum Overload Protection
		kW	BTUH				kW	BTUH			
No Heater	0	-	-	7.5 **	9	15	-	-	7.5 **	9	15
BAYEAAC04++1	1	3.84	13100	16.0	29	30	2.88	9800	13.8	27	30
BAYEAAC05++1	1	4.80	16400	20.0	34	35	3.60	12300	17.3	31	35
BAYEAAC08++1	1	7.68	26200	32.0	49	50	5.76	19700	27.7	44	45
BAYEAAC10++1	1	9.60	32800	40.0	59	60	7.20	24600	34.6	53	60
BAYEAAC10LG3	1-3 PH	9.60	32800	23.1	38	40	7.20	24600	20.0	34	35
BAYEABC15LG3	1-3 PH	14.40	42000	34.6	53	60	10.80	36900	30.0	47	50
BAYEABC15BK1 - Circuit 1 (a) BAYEABC15BK1 - Circuit 2	2	9.60	32800	40.0	59	60	7.20	24600	34.6	53	60
		4.80	16400	20.0	25	25	3.60	12300	17.3	22	25
BAYEABC20BK1 - Circuit 1 (a) BAYEABC20BK1 - Circuit 2	2	9.60	32800	40.0	59	60	7.20	24600	34.6	53	60
		9.60	32800	40.0	50	50	7.20	24600	34.6	43	45
BAYEACC25BK1 (b) - Circuit 1 (a) BAYEACC25BK1 - Circuit 2 BAYEACC25BK1 - Circuit 3	3	9.60	32800	40.0	59	60	7.20	24600	34.6	53	60
		9.60	32800	40.0	50	50	7.20	24600	34.6	43	45
		4.80	16400	20.0	25	25	3.60	12300	17.3	22	25

Note: ** Motor Amps

(a) MCA and MOP for circuit 1 contains the motor amps

(b) Heater not qualified for 208V when installed in horizontal left position without Heat Pump

Note: See Product Data or Air Handler nameplate for approved combinations of Air Handlers and Heaters.

Note: Heater model numbers may have additional suffix digits.

TAM9 Air Handler and Heater Matrix Allowable Combinations

APPROVED AIR HANDLER — HEATER COMBINATIONS						
HEATER MODEL NUMBER BAYEA-	AIR HANDLER MODEL NUMBER					
	TAM9A0A24V21DB	TAM9A0B30V31DB	TAM9A0C36V31DB	TAM9A0C42V41DB	TAM9A0C48V41DB	TAM9A0C60V51DB
AC04BK1 3.84 Kw BK	Y	Y	Y	Y	Y	Y
AC04LG1 3.84 Kw BK	Y	Y	Y	Y	Y	Y
AC05BK1 4.80 Kw BK	Y	Y	Y	Y	Y	Y
AC05LG1 4.80 Kw LG	Y	Y	Y	Y	Y	Y
AC08BK1 7.68 Kw BK	Y	Y	Y	Y	Y	Y
AC08LG1 7.68 Kw LG	Y	Y	Y	Y	Y	Y
AC10BK1 9.60 Kw BK	Y ^(a)	Y	Y	Y	Y	Y
AC10LG1 9.60 Kw LG	Y ^(a)	Y	Y	Y	Y	Y
BC15BK1 14.40 Kw BK	—	Y	Y	Y	Y	Y
BC20BK1 19.20 Kw BK	—	—	Y	Y	Y	Y
CC25BK1 24.00 Kw BK	—	—	—	—	Y	y ^(a)
AC10LG3 9.60 Kw LG	Y	Y	Y	Y	Y	Y
BC15LG3 14.4 Kw LG	—	Y	Y	Y	Y	Y

^(a) Heater is not qualified for 208V when installed in horizontal left position without HP.

Field Wiring

Communicating Controls Wiring Diagram

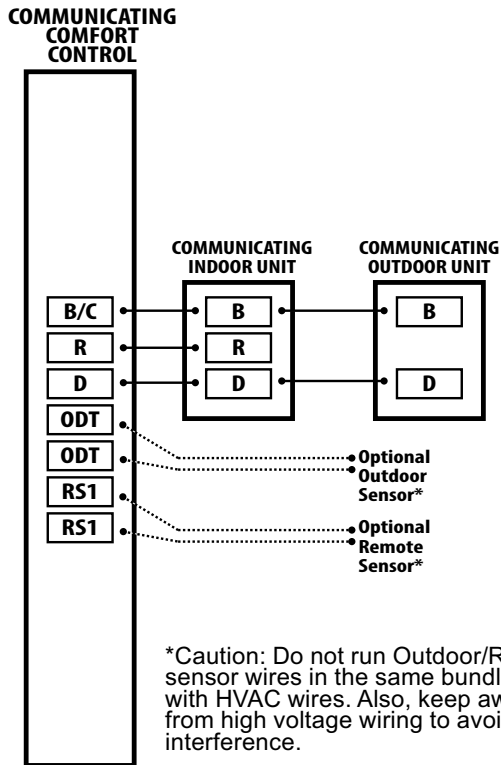

1 OR 2 STAGE COOLING WITH TAM9/TAMG VARIABLE SPEED AIR HANDLER

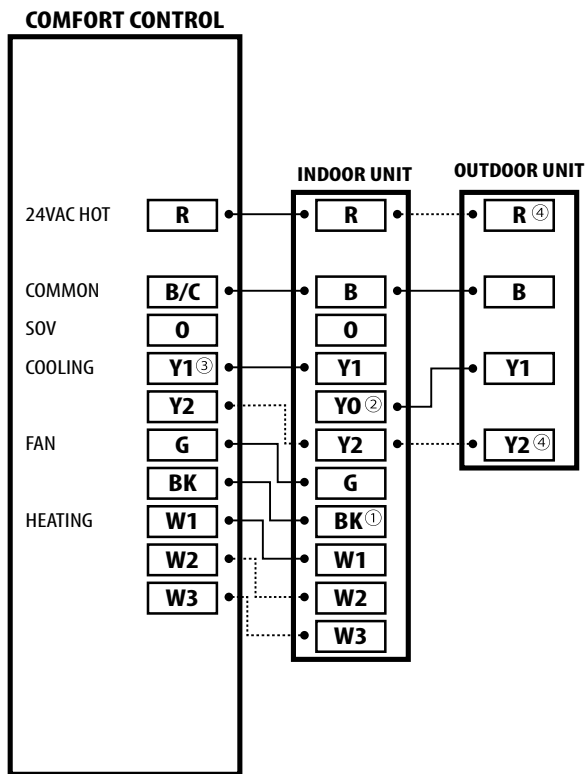

NOTES:

1. Cut the BK jumper on the AFC when using the BK functionality from the thermostat.
2. Y1 and Y0 connections must be made as shown for freeze protection and internally mounted condensate overflow circuits to function properly.
3. 3rd party condensate switches should break the Y1 circuit between the thermostat and AFC.
4. Y2 connections at outdoor unit are required only for two stage units.

Field Wiring

1 OR 2 STAGE HEAT PUMP WITH TAM9/TAMG VARIABLE SPEED AIR HANDLER

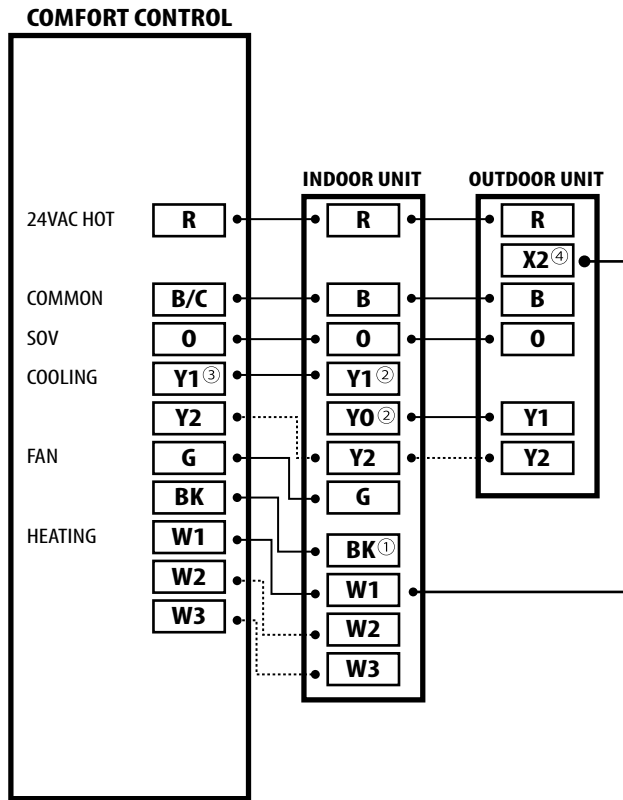

NOTES:

1. Cut the BK jumper on the AFC when using the BK functionality from the thermostat.
2. Y1 and YO connections must be made as shown for freeze protection and internally mounted condensate overflow circuits to function properly.
3. 3rd party condensate switches should break the Y1 circuit between the thermostat and AFC.
4. Connection to X2 is not required when using the 402, 624, 824, or relay panel controls.

Multi-position Air Handler

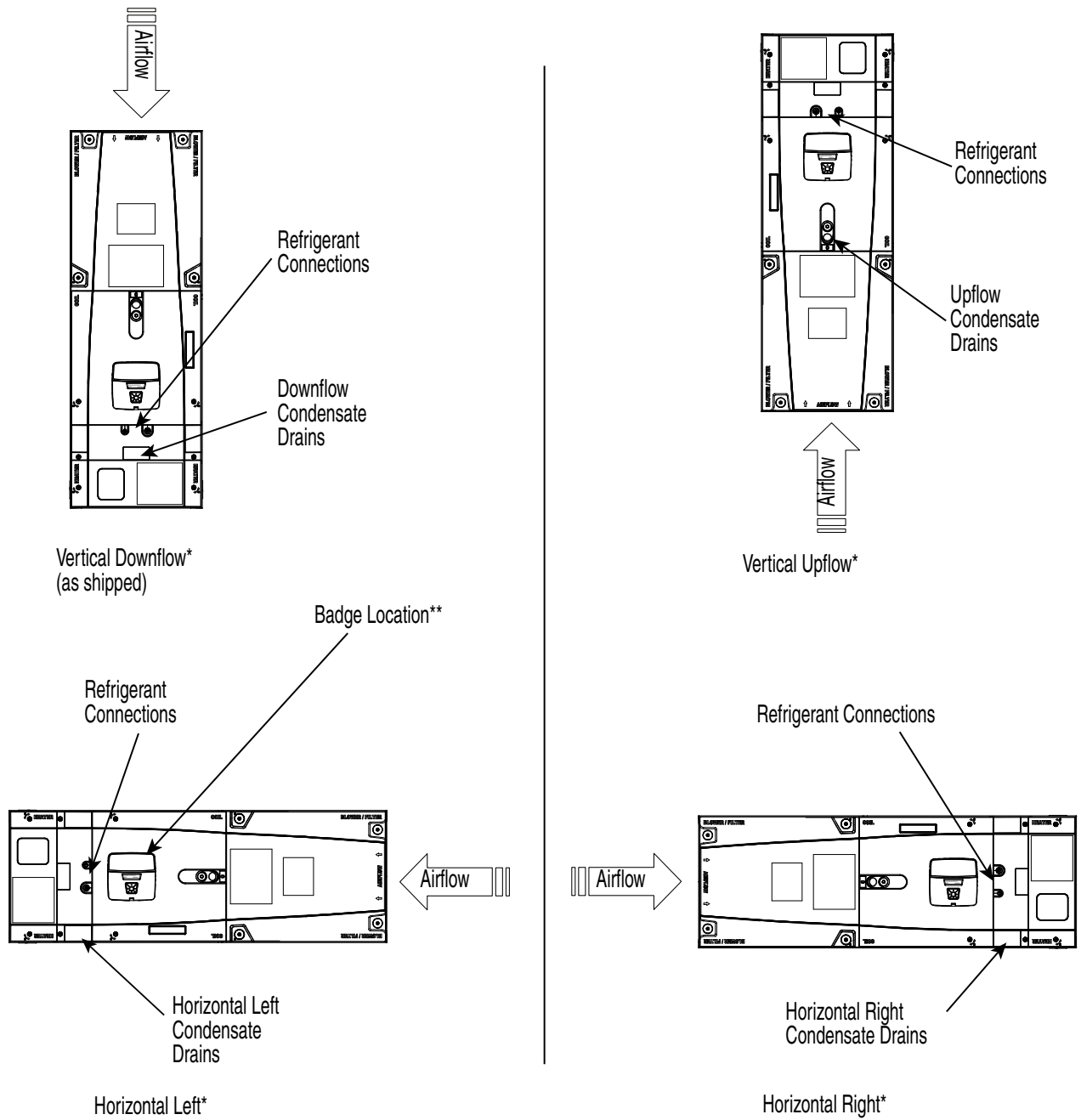

Note: * No internal modifications required for any position.
 ** CDA rotation will keep brand in correct position.

Unit Location Considerations

Table 1. Unit Dimensions and Weight

MODEL NUMBER	H x W x D (inches)	Coil and Heater Compartment Height * (inches)	Unit Net Weight (pounds)
TAM9A0A24V21DB	49.9 x 17.5 x 21.8	28.1	116
TAM9A0B30V31DB	55.7 x 21.3 x 21.8	33.9	138
TAM9A0C36V31DB	56.9 x 23.5 x 21.8	35.1	146
TAM9A0C42V41DB	56.9 x 23.5 x 21.8	35.1	150
TAM9A0C48V41DB	61.7 x 23.5 x 21.8	39.9	162
TAM9A0C60V51DB	61.7 x 23.5 x 21.8	39.9	163
* Blower compartment height is 21.8 inches.			

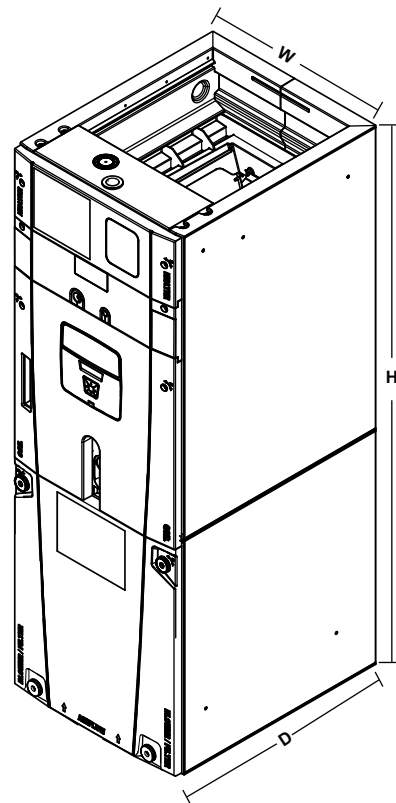

TAM9 OUTLINE DRAWING

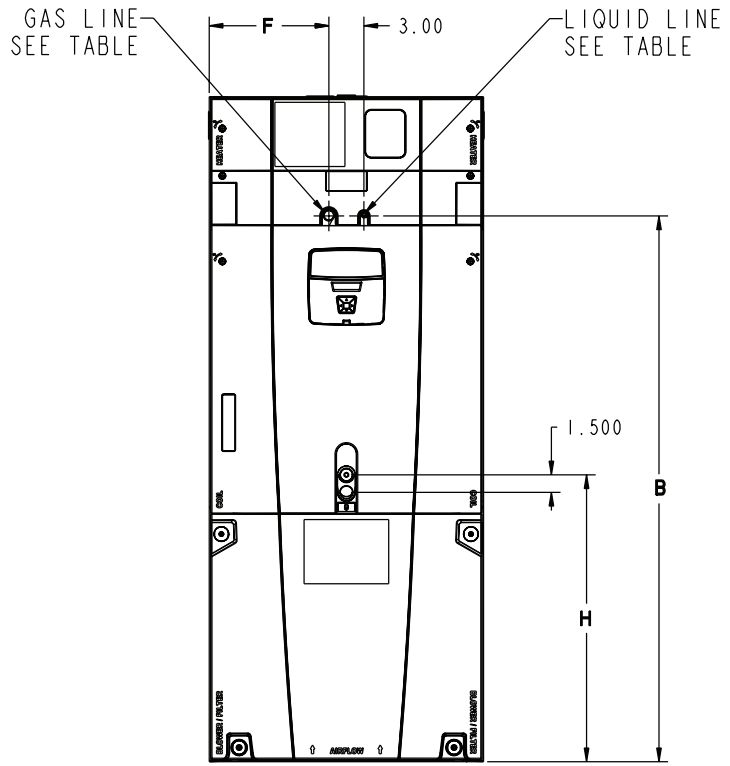
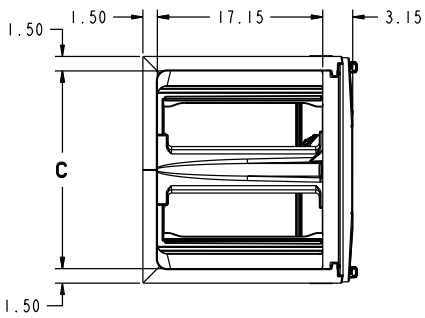
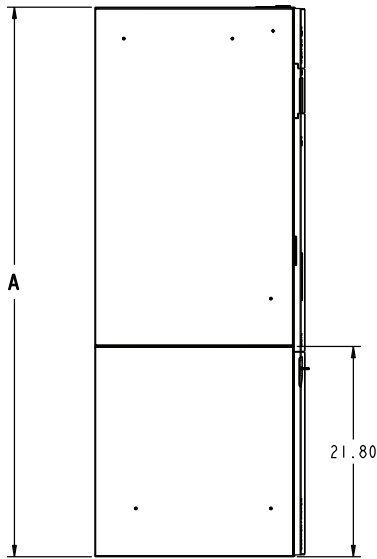
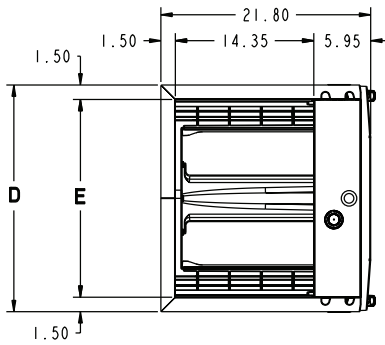

	SERVICE CLEARANCE (RECOMMENDED)
SIDES	2"
FRONT	21"
BACK	0"
INLET DUCT	
OUTLET DUCT	

NOTE: THIS UNIT IS APPROVED FOR INSTALLATION CLEARANCES TO COMBUSTIBLE MATERIAL AS STATED ON THE UNIT RATING NAMEPLATE

Model Number	A	B	C	D	E	F	H	FLOW CONTROL	GAS LINE BRAZE	LIQ LINE BRAZE
TAM9A0A24V21DB	49.9	39.6	14.5	17.5	14.5	7.3	24.4	EEV	3/4	3/8
TAM9A0B30V31DB	55.7	45.5	18.4	21.3	18.4	9.2	24.8	EEV	3/4	3/8
TAM9A0C36V31DB	56.9	46.7	20.5	23.5	20.5	10.3	24.2	EEV	7/8	3/8
TAM9A0C42V41DB	56.9	46.7	20.5	23.5	20.5	10.3	24.5	EEV	7/8	3/8
TAM9A0C48V41DB	61.7	51.5	20.5	23.5	20.5	10.3	24.9	EEV	7/8	3/8
TAM9A0C60V51DB	61.7	51.5	20.5	23.5	20.5	10.3	24.9	EEV	7/8	3/8

SUBCOOLING ADJUSTMENT

System Matched with:	Indoor Unit Model No.	Outdoor Unit Model No.	Subcooling
Single Compressor 2-Stage HP	TAM9A0B30V31DB	4A6H6024E/G, 4TWX6024E/G 4A6H7024, 4TWX8024	9 °
	TAM9A0C36V31DB	4A6H6036E/G, 4TWX6036E/G 4A6H7036, 4TWX8036	10 °
	TAM9A0C48V41DB	4A6H6048E/G, 4TWX6048E/G 4A6H7048, 4TWX8048	8 °
Single Compressor 2-Stage AC	TAM9A0B30V31DB	4A7A6024E/G, 4TTX6024E/G 4A7A7024, 4TTX8024	8 °
	TAM9A0C36V31DB	4A7A6036E/G, 4TTX6036E/G 4A7A7036, 4TTX8036	8 °
	TAM9A0C48V41DB	4A7A6048E/G, 4TTX6048E/G 4A7A7048, 4TTX8048	8 °
Two Compressor 2-Stage HP	TAM9A0B30V31DB	4A6Z0024A, 4TWZ0024A,	9 °
	TAM9A0C36V31DB	4A6Z0036A/B, 4TWZ0036A/B	10 °
	TAM9A0C48V41DB	4A6Z0048A/B 4TWZ0048A/B	12 °
	TAM9A0C60V51DB	4A6Z0060A, 4TWZ0060A	12 °
Two Compressor 2-Stage AC	TAM9A0B30V31DB	4A7Z0024A, 4TTZ0024A	9 °
	TAM9A0C36V31DB	4A7Z0036A/B, 4TTZ0036A/B	11 °
	TAM9A0C48V41DB	4A7Z0048A/B, 4TTZ0048A/B	12 °
Notes:			
1. Variable Speed Outdoor units must be charged per the outdoor unit instructions.			
2. All other matches must be charged per the nameplate charging instructions.			

American Standard[®]
HEATING & AIR CONDITIONING

About American Standard Heating and Air Conditioning

American Standard has been creating comfortable and affordable living environments for more than a century. For more information, please visit www.americanstandardair.com.



The manufacturer has a policy of continuous data improvement and it reserves the right to change design and specifications without notice. We are committed to using environmentally conscious print practices.

12-1394-1E-EN 04 Mar 2022
Supersedes 12-1394-1D-EN (April 2020)

©2022 American Standard Heating and Air Conditioning