

Product Data

Link Communicating or 24 Volt Gas-Fired 2 Stage Induced Draft Furnaces with Variable Speed Motor

Upflow, Downflow, Horizontal Right/Left
Two Stage

S8V2A040M3PC/D
S8V2B060M4PC/D
S8V2B080M4PC/D
S8V2C080M5PC/D
S8V2C100M5PC/D
S8V2D120M5PC/D

Note: Models that have a "D" in the 12th digit designating they meet California less than 40 ng/J (NOx) emissions requirements.

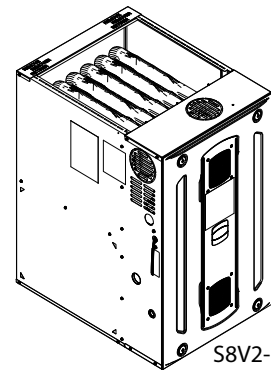

Note: Graphics in this document are for representation only. Actual model may differ in appearance.

Table of Contents

General Features	3
Features and Benefits.....	4
Accessories.....	5
Product Specification	6
Airflow Tables	8
Wiring Diagrams.....	17
Electrical Connections	18
24V Field Wiring	18
External Switches and Accessories.....	22
Outline Drawing	23

General Features

COMMUNICATING MODE

Furnace is shipped ready to be connected in communicating mode.

A/T LINK360A2VVUA Link Smart Thermostat and System Controller must be ordered separately.

COMFORT CONTROL

Link communicating technology seamlessly connects each of the system's components, allowing for advanced diagnostics, system performance updates, and optional remote monitoring that can help keep the system running at optimal performance levels throughout its lifetime.

ALTERNATE 24V MODE

Furnace is field configurable to 24V non-communicating mode.

NATURAL GAS MODELS

Central Heating furnace designs are certified by Intertek for both natural and L.P. gas. Limit setting and rating data were established and approved under standard rating conditions using American National Standards Institute standards.

SAFE OPERATION

The Integrated System Control is a solid state device which continuously monitors for presence of flame when the system is in the heating mode of operation. Dual solenoid combination gas valve and regulator provide additional safety.

QUICK HEATING

Durable, cycle tested, heavy gauge **tubular aluminized steel heat exchanger** quickly transfers heat to provide warm conditioned air to the structure. **Low energy power vent blower**, to increase efficiency and provide a discharge of gas fumes to the outside.

BURNERS

Multiport, Inshot burners will give years of quiet and efficient service. All models can be converted to **L.P. gas** with LP conversion kit.

INTEGRATED SYSTEM CONTROL

Exclusively designed operational program provides total control of furnace limit sensors, blowers, gas valve, flame control and includes self diagnostics for ease of service.

ENERGY EFFICIENT OPERATION

Air-Tite™ cabinet design is certified to <1% air leakage per ASHRAE 193 "Method of Test for Determining the Airtightness of HVAC Equipment."

AIR DELIVERY

The highly efficient, variable speed blower motor delivers consistent airflow and will switch from heating to cooling speeds on demand from the room thermostat.

STYLING

Heavy gauge steel and "wrap-around" cabinet construction is used in the cabinet with baked-on enamel finish for strength and beauty. Every orientation has at least two venting options. There are no knockouts on cabinet.

FEATURES AND GENERAL OPERATION

The S-Series furnace utilizes a Silicon Nitride Hot Surface Ignition system, which eliminates the waste of a constant burning pilot. The integrated system control lights the main burners upon a demand for heat from the room thermostat. Complete front service access.

- a. Low energy power venter
- b. Vent proving pressure switches.

Features and Benefits

LINK COMMUNICATION OR 24 VOLT CONTROL

Seamless connection between system components to monitor system performance and efficiency

Diagnostics and configuration capability through Mobile App

Field configurable to 24 volt non-communicating mode

80% AFUE on S8V2 FURNACE MODELS

Lowers utility bills

ELECTRICALLY EFFICIENT

Efficient airflow design reduces electrical energy use

34 INCH TALL

Lighter, easier to move and fit into tight spaces like short basements or tight closets

Works great with larger, high-efficiency coils

No knockouts

4-WAY MULTI-POISE

12 SKU's — Upflow / Downflow / Horizontal Left / Horizontal Right

Added application flexibility and reduction in specification errors

AIRFLOW

At least 400 CFM/ton at 0.5 in. H₂O external static pressure

REGULATORY

All models are air tight; 1% or less air leakage as per ASHRAE 193

Open vestibule design provides a full 34" high open vestibule for ease of installation and service

DIMENSIONS

Widths are industry standard: 14.5", 17.5", 21" and 24.5". Depth remains approximately 28"

Cabinet is compatible with industry standard coils, as well as, other accessories

INTEGRATED FURNACE CONTROL

Setup / Status / Diagnostics / Digital Display

No dip switches

Last six errors stored

Dry contact EAC and HUM connections

All Molex connections; no spade terminals

Low voltage labeled above and below

Rain shield over IFC keeps condensate off the control

TUBULAR ALUMINIZED STEEL HEAT EXCHANGER

VORTICA II BLOWER, DESIGNED EXCLUSIVELY FOR THE S-SERIES FURNACE

Improved airflow efficiency

Durable, easy to clean, housing

Single piece belly band/ motor arm assembly

Blower deck has full-length rails for easy removal and replacement, regardless of poise

FOUR-WAY MULTI-POISE (UPFLOW, DOWNFLOW, HORIZONTAL LEFT AND RIGHT)

Easier to specify

Shipped ready to install (no conversion kits required)

Every model has at least two venting options

Accessories

Table 1. Accessories

Model Number	Description	Use with
BAYHANG	Horizontal Hanging Kit	All Furnaces
BAYSENSC360	Supply Air Temperature Sensor	All Furnaces
BAYFURNPTKT	Return Air Static Pressure Sensor	All Furnaces
BAYLIFTB	Dual Return Kit (B size extension)	B Cabinet Furnaces
BAYLIFTC	Dual Return Kit (C size extension)	C Cabinet Furnaces
BAYLIFTD	Dual Return Kit (D size extension)	D Cabinet Furnaces
BAYBASE205	Downflow Subbase	All Furnaces in Downflow orientation
BAYSF1165AA ^(a)	1" SlimFit Box with MERV 4 Filter	All Furnaces
BAYSF1255BA	1" SlimFit Filter and Insulated Frame	All furnaces when used in side return application B Cabinet furnaces only when in bottom return application
FLRSF1255	1" Filter replacement (Qty 12)	BAYSF1255BA
BAYVENT600A	Internal venting kit	B, C, and D Furnaces in Downflow orientation
BAYVENT800B	Masonry Chimney Vent Kit	All furnaces
BAYSWT22AHALTAA	High Altitude Pressure Switch Kit	S8V2A040M3P*
BAYSWT16AHALTAB	High Altitude Pressure Switch Kit	S8V2C080M5P*
BAYSWT18AHALTAA	High Altitude Pressure Switch Kit	S8V2B080M4P*
BAYSWT19AHALTAA	High Altitude Pressure Switch Kit	S8V2C100M5P*
BAYSWT23AHALTAA	High Altitude Pressure Switch Kit	S8V2B060M4P*
BAYSWT24AHALTAA	High Altitude Pressure Switch Kit	S8V2D120M5P*
BAYLPSS400*	Propane Conversion Kit with Stainless Steel Burners	All Furnaces
PIP02095	U fitting for gas piping	All Furnaces for right hand gas entry
* Denotes latest revision.		

^(a) Airflow greater than 1600 CFM requires dual returns

Product Specification

Model	S8V2A040M3PC^(a) S8V2A040M3PD^(a)	S8V2B060M4PC^(a) S8V2B060M4PD^(a)	S8V2B080M4PC^(a) S8V2B080M4PD^(a)
Type	Upflow / Horizontal / Downflow	Upflow / Horizontal / Downflow	Upflow / Horizontal / Downflow
RATINGS^(b)			
1st Stage Input BTUH	26,000	39,000	52,000
1st Stage Capacity BTUH (ICS)	21,000	31,300	41,200
2nd Stage Input BTUH	40,000	60,000	80,000
2nd Stage Capacity BTUH (ICS) ^(c)	32,200	49,100	65,800
1st Stage Temp. Rise (Min. - Max.) °F	20 - 50	20 - 50	30 - 60
2nd Stage Temp. Rise (Min. - Max.) °F	30 - 60	30 - 60	30 - 60
AFUE - Rating ^(c)	80	80	80
Return Air Temp. (Min. - Max.) °F	55°F - 80°F	55°F - 80°F	55°F - 80°F
BLOWER DRIVE	DIRECT	DIRECT	DIRECT
Diameter - Width (in.)	11 X 8	11 X 8	11 X 8
No. Used	1	1	1
Speeds (No.) ^(d)	Variable	Variable	Variable
CFM vs. in. w.g.	See Fan Performance Table	See Fan Performance Table	See Fan Performance Table
Motor HP	1/2	3/4	3/4
R.P.M.	Variable	Variable	Variable
Volts / Ph / Hz	120 / 1 / 60	120 / 1 / 60	120 / 1 / 60
FLA	6.4	8	8
COMBUSTION FAN - Type	PSC	PSC	PSC
Drive - No. Speeds	Direct - 2	Direct - 2	Direct - 2
Motor HP - RPM	3200/2700	3200/2700	3200/2900
Volts/Ph/Hz	120 / 1 / 60	120 / 1 / 60	120 / 1 / 60
FLA	0.30	0.30	0.33
Inducer Orifice	1.20	1.40	1.75
FILTER - Furnished?	No	No	No
Type Recommended	High Velocity	High Velocity	High Velocity
Hi Vel. (No.-Size-Thk.)	1 - 14 X 25 - 1 in.	1 - 16 X 25 - 1 in.	1 - 16 X 25 - 1 in.
VENT PIPE DIAMETER - Min. (in.)^(e)	4 Round	4 Round	4 Round
HEAT EXCHANGER - Type	Aluminized Steel	Aluminized Steel	Aluminized Steel
Gauge (Fired)	20 - 19	20 - 19	20 - 19
ORIFICES - Main			
Nat. Gas Qty. - Drill Size	2 - 45	3 - 45	4 - 45
L.P. Gas Qty. - Drill Size	2 - 56	3 - 56	4 - 56
GAS VALVE	Redundant - Two Stage	Redundant - Two Stage	Redundant - Two Stage
PILOT SAFETY DEVICE - Type	120 V SiNi Igniter	120 V SiNi Igniter	120 V SiNi Igniter
BURNERS - QTY	2	3	4
POWER CONN. - V/Ph/HZ^(f)	120 / 1 / 60	120 / 1 / 60	120 / 1 / 60
Ampacity (Amps)	8.5	10.5	10.5
Max. Overcurrent Protection (Amps)	15	15	15
PIPE CONN. SIZE (IN.)	1/2	1/2	1/2
DIMENSIONS	H x W x D	H x W x D	H x W x D
Uncrated (in.)	34 x 14.5 x 28.75	34 x 17.5 x 28.75	34 x 17.5 x 28.75
Crated (in.)	35.5 x 16.5 x 30.87	35.5 x 19.5 x 30.87	35.5 x 19.5 x 30.87
WEIGHT			
Shipping (Lbs.)/Net (Lbs.)	102/94	132/124	137/129

(a) Central Furnace heating designs are certified to ANSI Z21.47 - latest edition.

(b) For U.S. applications, above input ratings (BTUH) are up to 2,000 feet, derate 4% per 1,000 feet for elevations above 2,000 feet above sea level.

(c) Based on U.S. government standard tests.

(d) Direct drive variable speed blower motor is an ECM constant airflow blower motor.

(e) Refer to the Installation, Operation, and Maintenance Manual.

(f) The above wiring specifications are in accordance with National Electric Code, however, installations must comply with local codes.

Product Specification

Model	S8V2C080M5PC^(a) S8V2C080M5PD^(a)	S8V2C100M5PC^(a) S8V2C100M5PD^(a)	S8V2D120M5PC^(a) S8V2D120M5PD^(a)
Type	Upflow / Horizontal / Downflow	Upflow / Horizontal / Downflow	Upflow / Horizontal / Downflow
RATINGS^(b)			
1st Stage Input BTUH	52,000	65,000	84,000
1st Stage Capacity BTUH (ICS)	41,800	52,300	67,900
2nd Stage Input BTUH	80,000	100,000	120,000
2nd Stage Capacity BTUH (ICS) ^(c)	64,800	81,200	98,000
1st Stage Temp. Rise (Min. - Max.) °F	30 - 60	25 - 55	30 - 60
2nd Stage Temp. Rise (Min. - Max.) °F	30 - 60	30 - 60	35 - 65
AFUE - Rating ^(c)	80	80	80
Return Air Temp. (Min. - Max.) °F	55°F - 80°F	55°F - 80°F	55°F - 80°F
BLOWER DRIVE	DIRECT	DIRECT	DIRECT
Diameter - Width (in.)	11 X 11	11 X 11	11 X 11
No. Used	1	1	1
Speeds (No.) ^(d)	Variable	Variable	Variable
CFM vs. in. w.g.	See Fan Performance Table	See Fan Performance Table	See Fan Performance Table
Motor HP	1	1	1
R.P.M.	Variable	Variable	Variable
Volts / Ph / Hz	120 / 1 / 60	120 / 1 / 60	120 / 1 / 60
FLA	10	10	10
COMBUSTION FAN - Type	PSC	PSC	PSC
Drive - No. Speeds	Direct - 2	Direct - 2	Direct - 2
Motor HP - RPM	3200/2700	3200/2900	3200/2900
Volts/Ph/Hz	120 / 1 / 60	120 / 1 / 60	120 / 1 / 60
FLA	0.30	0.33	0.33
Inducer Orifice	1.80	2.50	2.15
FILTER - Furnished?	No	No	No
Type Recommended	High Velocity	High Velocity	High Velocity
Hi Vel. (No.-Size-Thk.)	1 - 20 X 25 - 1 in.	1 - 20 X 25 - 1 in.	1 - 24 X 25 - 1 in.
VENT PIPE DIAMETER - Min. (in.)^(e)	4 Round	4 Round	4 Round
HEAT EXCHANGER - Type	Aluminized Steel	Aluminized Steel	Aluminized Steel
Gauge (Fired)	20 - 19	20 - 19	20 - 19
ORIFICES - Main			
Nat. Gas Qty. - Drill Size	4 - 45	5 - 45	6 - 45
L.P. Gas Qty. - Drill Size	4 - 56	5 - 56	6 - 56
GAS VALVE	Redundant - Two Stage	Redundant - Two Stage	Redundant - Two Stage
PILOT SAFETY DEVICE - Type	120 V SiNi Igniter	120 V SiNi Igniter	120 V SiNi Igniter
BURNERS - QTY	4	5	6
POWER CONN. - V/Ph/HZ^(f)	120 / 1 / 60	120 / 1 / 60	120 / 1 / 60
Ampacity (Amps)	13.0	13.0	13.0
Max. Overcurrent Protection (Amps)	15	15	15
PIPE CONN. SIZE (IN.)	1/2	1/2	1/2
DIMENSIONS	H x W x D	H x W x D	H x W x D
Uncrated (in.)	34 x 21 x 28.75	34 x 21 x 28.75	34 x 24.5 x 28.75
Crated (in.)	35.5 x 23 x 30.87	35.5 x 23 x 30.87	35.5 x 26.5 x 30.87
WEIGHT			
Shipping (Lbs.)/Net (Lbs.)	142/134	144/136	160/152

^(a) Central Furnace heating designs are certified to ANSI Z21.47 - latest edition.

^(b) For U.S. applications, above input ratings (BTUH) are up to 2,000 feet, derate 4% per 1,000 feet for elevations above 2,000 feet above sea level.

^(c) Based on U.S. government standard tests.

^(d) Direct drive variable speed blower motor is an ECM constant airflow blower motor.

^(e) Refer to the Installation, Operation, and Maintenance Manual.

^(f) The above wiring specifications are in accordance with National Electric Code, however, installations must comply with local codes.

Airflow Tables

Table 2. S8V2A040M3P Heating Airflow

S8V2A040M3P Furnace Heating Airflow (CFM), Temp. Rise (°F), and Power (Watts) vs. External Static Pressure with Filter (iwc)								
				1st Stage Capacity = 21,000 2nd Stage Capacity = 32,200				
Heating	Airflow Setting	Target Airflow		External Static Pressure				
				0.1	0.3	0.5	0.7	0.9
Heating 1st Stage	Low	427	CFM	458	459	460	461	462
			Temp. Rise	42	42	42	41	41
			Watts	23	55	87	119	151
	Medium Low ^(a)	506	CFM	521	522	524	525	527
			Temp. Rise	37	37	37	37	37
			Watts	30	64	98	132	166
	Medium	593	CFM	611	605	598	592	585
			Temp. Rise	32	33	33	33	34
			Watts	40	76	112	149	185
	High	672	CFM	694	680	667	653	639
			Temp. Rise	28	29	29	30	31
			Watts	50	88	126	164	202
Heating 2nd Stage	Low	540	CFM	605	601	596	591	586
			Temp. Rise	49	49	50	50	50
			Watts	32	71	109	148	187
	Medium Low ^(a)	640	CFM	660	661	662	663	664
			Temp. Rise	45	45	45	45	45
			Watts	44	84	125	165	206
	Medium	750	CFM	785	779	773	768	762
			Temp. Rise	39	39	39	39	40
			Watts	64	108	152	196	240
	High	850	CFM	898	887	875	863	851
			Temp. Rise	33	33	34	34	35
			Watts	82	130	177	224	272

Table 3. S8V2A040M3P Cooling Airflow

S8V2A040M3P Furnace Cooling Airflow (CFM) and Power (Watts) vs. External Static Pressure with Filter (iwc)							
Outdoor Tonnage - "Odt" (tons)	Airflow Setting - "CPC" (CFM/ton)		EXTERNAL STATIC PRESSURE (IN. W. C.)				
			0.1	0.3	0.5	0.7	0.9
1.5	450	CFM / WATTS	672 / 52	655 / 91	641 / 134	627 / 180	611 / 228
	420	CFM / WATTS	630 / 45	611 / 83	596 / 124	581 / 168	566 / 215
	400	CFM / WATTS	601 / 41	581 / 78	566 / 118	551 / 161	535 / 207
	370	CFM / WATTS	558 / 35	537 / 70	521 / 109	505 / 151	489 / 196
	350	CFM / WATTS	529 / 32	507 / 66	490 / 104	475 / 145	458 / 189
	330	CFM / WATTS	500 / 29	477 / 62	460 / 98	444 / 139	427 / 183
	310	CFM / WATTS	471 / 26	447 / 58	429 / 94	413 / 133	396 / 176
	290	CFM / WATTS	437 / 23	405 / 53	400 / 89	363 / 125	326 / 165
2.0	450	CFM / WATTS	869 / 93	863 / 142	852 / 193	823 / 240	800 / 291
	420	CFM / WATTS	827 / 82	814 / 128	803 / 177	790 / 228	776 / 281
	400	CFM / WATTS	790 / 74	776 / 118	764 / 166	751 / 215	736 / 267
	370	CFM / WATTS	734 / 63	718 / 105	705 / 150	692 / 198	677 / 248
	350	CFM / WATTS	690 / 55	680 / 96	646 / 136	632 / 181	628 / 233
	330	CFM / WATTS	658 / 49	640 / 88	626 / 131	612 / 176	596 / 224
	310	CFM / WATTS	620 / 44	601 / 81	586 / 122	571 / 166	555 / 213
	290	CFM / WATTS	582 / 38	562 / 74	546 / 114	531 / 157	515 / 202

Airflow Tables

Table 3. S8V2A040M3P Cooling Airflow (continued)

S8V2A040M3P Furnace Cooling Airflow (CFM) and Power (Watts) vs. External Static Pressure with Filter (iwc)							
Outdoor Tonnage - "Odt" (tons)	Airflow Setting - "CPC" (CFM/ton)		EXTERNAL STATIC PRESSURE (IN. W. C.)				
			0.1	0.3	0.5	0.7	0.9
2.5	450	CFM / WATTS	1087 / 163	1065 / 212	1074 / 278	1064 / 339	1052 / 402
	420	CFM / WATTS	1019 / 138	998 / 186	1004 / 248	993 / 306	981 / 366
	400	CFM / WATTS	974 / 123	953 / 171	945 / 225	922 / 277	902 / 331
	370	CFM / WATTS	898 / 101	886 / 149	876 / 200	848 / 248	825 / 300
	350	CFM / WATTS	859 / 90	848 / 137	837 / 187	824 / 240	810 / 294
	330	CFM / WATTS	813 / 79	800 / 124	788 / 173	775 / 223	761 / 276
	310	CFM / WATTS	766 / 69	752 / 112	739 / 159	726 / 208	711 / 259
3.0 ^(a)	290	CFM / WATTS	719 / 60	704 / 101	690 / 146	677 / 193	661 / 243
	450	CFM / WATTS	1288 / 255	1286 / 319	1282 / 386	1274 / 455	1264 / 525
	420	CFM / WATTS	1208 / 215	1205 / 276	1199 / 340	1191 / 405	1180 / 473
	400	CFM / WATTS	1155 / 190	1150 / 249	1144 / 311	1135 / 375	1124 / 440
	370	CFM / WATTS	1074 / 157	1068 / 213	1060 / 272	1050 / 332	1038 / 394
	350 ^(a)	CFM / WATTS	1019 / 138	1012 / 191	1004 / 248	993 / 306	981 / 366
	330	CFM / WATTS	965 / 120	956 / 171	947 / 226	936 / 282	923 / 340
	310	CFM / WATTS	910 / 104	900 / 153	889 / 205	878 / 259	864 / 315
	290	CFM / WATTS	854 / 89	843 / 136	832 / 186	820 / 238	805 / 292

Table 4. S8V2B060M4P Heating Airflow

S8V2B060M4P Furnace Heating Airflow (CFM), Temp. Rise (°F), and Power (Watts) vs. External Static Pressure with Filter (iwc)								
				1st Stage Capacity = 31,300 2nd Stage Capacity = 49,100				
Heating	Airflow Setting	Target Airflow		External Static Pressure				
				0.1	0.3	0.5	0.7	0.9
Heating 1st Stage	Low	711	CFM	690	687	684	681	678
			Temp. Rise	42	42	42	43	43
			Watts	44	83	122	161	200
	Medium Low ^(a)	830	CFM	808	812	816	820	824
			Temp. Rise	36	36	36	36	35
			Watts	63	107	151	194	238
	Medium	948	CFM	917	921	925	929	932
			Temp. Rise	32	32	32	32	32
			Watts	87	137	186	235	285
	High	1106	CFM	1063	1067	1070	1074	1077
			Temp. Rise	27	27	27	27	27
			Watts	119	176	233	289	347
Heating 2nd Stage	Low	900	CFM	880	880	879	878	877
			Temp. Rise	51	51	51	51	50
			Watts	71	121	172	223	273
	Medium Low ^(a)	1050	CFM	1037	1032	1027	1021	1016
			Temp. Rise	43	44	44	43	44
			Watts	108	162	216	269	323
	Medium	1200	CFM	1179	1175	1171	1168	1164
			Temp. Rise	39	39	39	39	39
			Watts	165	226	287	347	408
	High	1400	CFM	1367	1366	1364	1363	1361
			Temp. Rise	33	33	33	33	33
			Watts	240	311	381	451	522

Airflow Tables

Table 5. S8V2B060M4P Cooling Airflow

S8V2B060M4P Furnace Cooling Airflow (CFM) and Power (Watts) vs. External Static Pressure with Filter (iwc)							
Outdoor Tonnage - "Odt" (tons)	Airflow Setting - "CPC" (CFM/ton)		EXTERNAL STATIC PRESSURE (IN. W. C.)				
			0.1	0.3	0.5	0.7	0.9
1.5	450	CFM / WATTS	650 / 42	649 / 77	653 / 116	658 / 159	659 / 205
	420	CFM / WATTS	600 / 36	599 / 69	604 / 107	609 / 149	611 / 195
	400	CFM / WATTS	567 / 33	566 / 65	571 / 102	576 / 143	578 / 189
	370	CFM / WATTS	518 / 28	516 / 59	521 / 94	526 / 135	529 / 180
	350	CFM / WATTS	484 / 25	483 / 55	488 / 90	493 / 130	496 / 176
	330	CFM / WATTS	451 / 23	449 / 51	455 / 86	460 / 126	462 / 171
	310	CFM / WATTS	417 / 20	415 / 48	421 / 82	426 / 122	429 / 167
	290	CFM / WATTS	325 / 15	325 / 41	340 / 75	346 / 115	326 / 161
2.0	450	CFM / WATTS	892 / 81	892 / 124	895 / 171	898 / 220	899 / 272
	420	CFM / WATTS	828 / 69	828 / 110	832 / 154	835 / 202	836 / 252
	400	CFM / WATTS	785 / 61	785 / 101	789 / 144	792 / 190	793 / 240
	370	CFM / WATTS	720 / 51	720 / 89	724 / 130	728 / 174	729 / 222
	350	CFM / WATTS	677 / 45	676 / 81	681 / 121	685 / 164	686 / 212
	330	CFM / WATTS	633 / 40	632 / 74	637 / 113	641 / 155	643 / 202
	310	CFM / WATTS	589 / 35	588 / 68	593 / 105	598 / 147	600 / 193
	290	CFM / WATTS	545 / 31	544 / 62	549 / 98	554 / 139	556 / 185
2.5	450	CFM / WATTS	1127 / 142	1128 / 193	1131 / 248	1133 / 305	1132 / 365
	420	CFM / WATTS	1040 / 117	1042 / 165	1045 / 217	1047 / 271	1046 / 327
	400	CFM / WATTS	997 / 105	998 / 152	1001 / 202	1003 / 255	1003 / 310
	370	CFM / WATTS	918 / 87	919 / 131	922 / 178	925 / 228	925 / 281
	350	CFM / WATTS	865 / 76	865 / 118	869 / 164	872 / 212	873 / 264
	330	CFM / WATTS	812 / 66	812 / 106	816 / 150	819 / 197	820 / 247
	310	CFM / WATTS	758 / 57	758 / 95	762 / 138	766 / 183	767 / 232
	290	CFM / WATTS	704 / 49	703 / 86	708 / 126	712 / 170	713 / 218
3.0	450	CFM / WATTS	1355 / 228	1358 / 288	1360 / 352	1361 / 417	1358 / 485
	420	CFM / WATTS	1265 / 190	1267 / 247	1269 / 307	1270 / 369	1268 / 433
	400	CFM / WATTS	1204 / 167	1205 / 222	1208 / 279	1209 / 339	1208 / 402
	370	CFM / WATTS	1111 / 137	1113 / 188	1116 / 242	1117 / 299	1116 / 358
	350	CFM / WATTS	1049 / 119	1050 / 168	1053 / 220	1055 / 274	1055 / 331
	330	CFM / WATTS	987 / 103	987 / 149	991 / 199	993 / 251	993 / 306
	310	CFM / WATTS	923 / 88	924 / 132	927 / 180	930 / 230	930 / 283
	290	CFM / WATTS	860 / 75	860 / 117	864 / 162	867 / 211	867 / 262
3.5	450	CFM / WATTS	1576 / 345	1580 / 414	1582 / 486	1582 / 560	1578 / 636
	420	CFM / WATTS	1474 / 286	1477 / 351	1479 / 419	1479 / 489	1476 / 561
	400	CFM / WATTS	1405 / 251	1408 / 314	1410 / 379	1410 / 446	1408 / 516
	370	CFM / WATTS	1300 / 204	1302 / 262	1305 / 324	1305 / 387	1303 / 453
	350	CFM / WATTS	1229 / 177	1231 / 232	1234 / 291	1235 / 351	1233 / 414
	330	CFM / WATTS	1158 / 152	1159 / 204	1162 / 260	1163 / 319	1162 / 379
	310	CFM / WATTS	1085 / 129	1087 / 179	1090 / 232	1092 / 288	1091 / 346
	290	CFM / WATTS	1013 / 109	1014 / 157	1017 / 207	1019 / 261	1019 / 316
4.0 ^(a)	450	CFM / WATTS	1791 / 497	1795 / 575	1797 / 656	1796 / 739	1791 / 823
	420	CFM / WATTS	1677 / 411	1681 / 485	1683 / 561	1683 / 639	1678 / 719
	400	CFM / WATTS	1601 / 360	1604 / 430	1606 / 503	1606 / 578	1602 / 655
	370	CFM / WATTS	1484 / 291	1487 / 357	1489 / 425	1489 / 496	1486 / 568
	350 ^(a)	CFM / WATTS	1405 / 251	1408 / 314	1410 / 379	1410 / 446	1408 / 516
	330	CFM / WATTS	1325 / 215	1327 / 274	1330 / 336	1331 / 401	1328 / 467
	310	CFM / WATTS	1244 / 182	1246 / 238	1249 / 297	1250 / 359	1248 / 422
	290	CFM / WATTS	1163 / 153	1164 / 206	1167 / 262	1169 / 321	1167 / 381

Airflow Tables

Table 6. S8V2B080M4P Heating Airflow

S8V2B080M4P Furnace Heating Airflow (CFM), Temp. Rise (°F), and Power (Watts) vs. External Static Pressure with Filter (iwc)								
				1st Stage Capacity = 41,200 2nd Stage Capacity = 65,800				
Heating	Airflow Setting	Target Airflow		External Static Pressure				
				0.1	0.3	0.5	0.7	0.9
Heating 1st Stage	Low	689	CFM	692	684	678	670	664
			Temp. Rise	56	56	57	57	58
			Watts	50	93	136	179	222
	Medium Low ^(a)	865	CFM	854	858	861	864	867
			Temp. Rise	45	45	45	45	45
			Watts	78	125	173	221	268
	Medium	956	CFM	947	941	936	930	924
			Temp. Rise	41	41	42	42	42
			Watts	100	151	201	252	302
	High	1040	CFM	1033	1019	1005	991	978
			Temp. Rise	37	38	38	39	40
			Watts	121	174	227	280	334
Heating 2nd Stage	Low	1060	CFM	1071	1068	1065	1061	1058
			Temp. Rise	56	56	56	56	57
			Watts	107	180	254	327	401
	Medium Low ^(a)	1330	CFM	1320	1318	1315	1313	1311
			Temp. Rise	45	45	45	45	45
			Watts	211	287	364	441	517
	Medium	1470	CFM	1460	1453	1446	1439	1432
			Temp. Rise	41	41	42	42	42
			Watts	305	383	460	538	615
	High	1600	CFM	1591	1579	1568	1556	1545
			Temp. Rise	38	38	38	38	38
			Watts	393	471	550	628	707

Table 7. S8V2B080M4P Cooling Airflow

S8V2B080M4P Furnace Cooling Airflow (CFM) and Power (Watts) vs. External Static Pressure with Filter (iwc)							
Outdoor Tonnage - "Odt" (tons)	Airflow Setting - "CPC" (CFM/ton)		EXTERNAL STATIC PRESSURE (IN. W. C.)				
			0.1	0.3	0.5	0.7	0.9
1.5	450	CFM / WATTS	692 / 42	684 / 78	678 / 119	672 / 163	667 / 212
	420	CFM / WATTS	647 / 37	639 / 71	632 / 110	626 / 153	621 / 201
	400	CFM / WATTS	617 / 33	609 / 66	602 / 105	596 / 147	591 / 194
	370	CFM / WATTS	572 / 28	563 / 60	556 / 97	550 / 139	545 / 185
	350	CFM / WATTS	542 / 26	533 / 56	526 / 92	520 / 134	515 / 180
	330	CFM / WATTS	512 / 23	502 / 53	495 / 88	489 / 129	484 / 175
	310	CFM / WATTS	481 / 21	472 / 49	465 / 84	459 / 125	453 / 170
	290	CFM / WATTS	450 / 18	443 / 46	450 / 82	450 / 123	417 / 166
2.0	450	CFM / WATTS	915 / 82	909 / 126	903 / 175	897 / 226	893 / 281
	420	CFM / WATTS	856 / 69	849 / 112	843 / 158	838 / 207	833 / 260
	400	CFM / WATTS	817 / 62	809 / 103	803 / 147	798 / 195	793 / 247
	370	CFM / WATTS	757 / 52	749 / 90	743 / 133	737 / 179	732 / 229
	350	CFM / WATTS	717 / 46	709 / 83	703 / 124	697 / 169	692 / 218
	330	CFM / WATTS	677 / 40	669 / 76	662 / 116	657 / 160	652 / 208
	310	CFM / WATTS	637 / 35	629 / 69	622 / 108	616 / 151	611 / 199
	290	CFM / WATTS	597 / 31	589 / 63	582 / 101	576 / 143	571 / 190
2.5	450	CFM / WATTS	1135 / 143	1130 / 196	1124 / 253	1120 / 312	1115 / 375
	420	CFM / WATTS	1062 / 119	1056 / 170	1050 / 224	1045 / 281	1041 / 340
	400	CFM / WATTS	1013 / 106	1007 / 154	1002 / 206	997 / 261	992 / 319
	370	CFM / WATTS	940 / 87	933 / 133	927 / 182	922 / 235	917 / 290
	350	CFM / WATTS	891 / 76	884 / 120	878 / 167	872 / 218	868 / 272
	330	CFM / WATTS	841 / 66	834 / 108	828 / 154	823 / 203	818 / 255
	310	CFM / WATTS	792 / 57	784 / 97	778 / 141	772 / 188	768 / 239
	290	CFM / WATTS	742 / 49	734 / 87	728 / 129	722 / 175	717 / 225

Airflow Tables

Table 7. S8V2B080M4P Cooling Airflow (continued)

S8V2B080M4P Furnace Cooling Airflow (CFM) and Power (Watts) vs. External Static Pressure with Filter (iwc)							
Outdoor Tonnage - "Odt" (tons)	Airflow Setting - "CPC" (CFM/ton)		EXTERNAL STATIC PRESSURE (IN. W. C.)				
			0.1	0.3	0.5	0.7	0.9
3.0	450	CFM / WATTS	1353 / 230	1348 / 292	1343 / 358	1339 / 426	1335 / 496
	420	CFM / WATTS	1266 / 192	1261 / 250	1256 / 312	1252 / 377	1247 / 444
	400	CFM / WATTS	1208 / 169	1203 / 225	1198 / 285	1193 / 347	1189 / 412
	370	CFM / WATTS	1121 / 138	1115 / 191	1110 / 247	1105 / 306	1101 / 367
	350	CFM / WATTS	1062 / 120	1056 / 170	1051 / 224	1046 / 281	1041 / 340
	330	CFM / WATTS	1004 / 103	997 / 151	992 / 203	987 / 258	982 / 315
	310	CFM / WATTS	945 / 88	938 / 134	932 / 184	927 / 236	922 / 292
	290	CFM / WATTS	886 / 75	879 / 119	873 / 166	867 / 216	863 / 270
3.5	450	CFM / WATTS	1568 / 349	1564 / 420	1559 / 494	1556 / 571	1552 / 650
	420	CFM / WATTS	1468 / 289	1463 / 356	1459 / 427	1455 / 499	1451 / 574
	400	CFM / WATTS	1401 / 253	1396 / 318	1392 / 385	1387 / 455	1383 / 528
	370	CFM / WATTS	1300 / 206	1295 / 266	1290 / 330	1286 / 396	1282 / 464
	350	CFM / WATTS	1232 / 178	1227 / 235	1222 / 296	1218 / 359	1213 / 425
	330	CFM / WATTS	1165 / 153	1159 / 207	1154 / 265	1149 / 326	1145 / 389
	310	CFM / WATTS	1096 / 130	1091 / 182	1085 / 237	1080 / 295	1076 / 356
	290	CFM / WATTS	1028 / 110	1022 / 159	1016 / 212	1011 / 267	1007 / 325
4.0 ^(a)	450	CFM / WATTS	1780 / 503	1776 / 584	1773 / 667	1769 / 753	1766 / 841
	420	CFM / WATTS	1667 / 416	1663 / 492	1659 / 570	1656 / 651	1652 / 734
	400	CFM / WATTS	1592 / 364	1587 / 436	1583 / 512	1579 / 590	1576 / 670
	370	CFM / WATTS	1477 / 294	1473 / 362	1469 / 433	1464 / 506	1461 / 581
	350 ^(a)	CFM / WATTS	1401 / 253	1396 / 318	1392 / 385	1387 / 455	1383 / 528
	330	CFM / WATTS	1324 / 217	1319 / 278	1314 / 342	1310 / 409	1306 / 478
	310	CFM / WATTS	1247 / 184	1242 / 242	1237 / 303	1232 / 367	1228 / 433
	290	CFM / WATTS	1169 / 154	1164 / 209	1159 / 267	1154 / 328	1150 / 392

Table 8. S8V2C080M5P Heating Airflow

S8V2C080M5P Furnace Heating Airflow (CFM), Temp. Rise (°F), and Power (Watts) vs. External Static Pressure with Filter (iwc)								
				1st Stage Capacity = 41,800 2nd Stage Capacity = 64,800				
Heating	Airflow Setting	Target Airflow		EXTERNAL STATIC PRESSURE				
				0.1	0.3	0.5	0.7	0.9
Heating 1st Stage	Low	748	CFM	771	741	711	682	652
			Temp. Rise	50	52	54	56	58
			Watts	46	90	134	178	221
	Medium Low ^(a)	878	CFM	879	854	830	805	781
			Temp. Rise	44	45	46	47	48
			Watts	59	116	174	232	290
	Medium	943	CFM	958	948	938	929	919
			Temp. Rise	40	41	41	42	42
			Watts	70	132	194	256	318
	High	1073	CFM	1035	1026	1016	1007	997
			Temp. Rise	37	38	38	39	40
			Watts	90	150	210	271	331
Heating 2nd Stage	Low	1150	CFM	1175	1159	1142	1126	1109
			Temp. Rise	50	51	52	53	53
			Watts	105	174	243	312	381
	Medium Low ^(a)	1350	CFM	1387	1373	1359	1345	1331
			Temp. Rise	43	43	43	44	44
			Watts	154	243	333	422	512
	Medium	1450	CFM	1446	1444	1443	1441	1439
			Temp. Rise	41	41	41	41	41
			Watts	94	215	336	457	577
	High	1650	CFM	1642	1621	1601	1580	1560
			Temp. Rise	36	36	37	37	38
			Watts	279	373	467	561	655

Airflow Tables

Table 9. S8V2C080M5P Cooling Airflow

S8V2C080M5P Furnace Cooling Airflow (CFM) and Power (Watts) vs. External Static Pressure with Filter (iwc)							
Outdoor Tonnage - "Odt" (tons)	Airflow Setting - "CPC" (CFM/ton)		EXTERNAL STATIC PRESSURE (IN. W. C.)				
			0.1	0.3	0.5	0.7	0.9
2.5	450	CFM / WATTS	1057 / 107	1057 / 168	1055 / 231	1051 / 296	1047 / 363
	420	CFM / WATTS	982 / 91	980 / 149	976 / 209	972 / 270	968 / 334
	400	CFM / WATTS	932 / 82	928 / 137	924 / 194	919 / 254	914 / 316
	370	CFM / WATTS	856 / 69	850 / 121	844 / 174	838 / 231	832 / 290
	350	CFM / WATTS	806 / 62	797 / 111	790 / 162	783 / 217	777 / 274
	330	CFM / WATTS	755 / 55	744 / 101	735 / 151	728 / 204	721 / 260
	310	CFM / WATTS	704 / 48	691 / 92	681 / 140	672 / 191	665 / 246
3.0	290	CFM / WATTS	652 / 42	637 / 84	625 / 130	616 / 180	608 / 233
	450	CFM / WATTS	1279 / 164	1284 / 237	1285 / 311	1283 / 387	1280 / 463
	420	CFM / WATTS	1190 / 139	1194 / 207	1194 / 277	1192 / 348	1188 / 421
	400	CFM / WATTS	1131 / 124	1133 / 189	1132 / 256	1130 / 324	1126 / 394
	370	CFM / WATTS	1042 / 104	1041 / 164	1039 / 227	1036 / 291	1032 / 357
	350	CFM / WATTS	982 / 91	980 / 149	976 / 209	972 / 270	968 / 334
	330	CFM / WATTS	922 / 80	918 / 135	913 / 192	908 / 251	903 / 312
3.5	310	CFM / WATTS	861 / 70	855 / 122	849 / 176	843 / 232	838 / 292
	290	CFM / WATTS	800 / 61	792 / 110	784 / 161	778 / 215	771 / 273
	450	CFM / WATTS	1498 / 238	1505 / 324	1508 / 410	1507 / 497	1504 / 585
	420	CFM / WATTS	1396 / 201	1402 / 281	1404 / 362	1404 / 443	1401 / 525
	400	CFM / WATTS	1328 / 179	1333 / 255	1335 / 332	1334 / 410	1331 / 489
	370	CFM / WATTS	1225 / 148	1229 / 219	1229 / 290	1227 / 363	1224 / 437
	350	CFM / WATTS	1156 / 130	1158 / 197	1158 / 265	1156 / 334	1152 / 405
4.0	330	CFM / WATTS	1087 / 114	1087 / 176	1086 / 241	1083 / 307	1079 / 375
	310	CFM / WATTS	1017 / 98	1016 / 158	1013 / 219	1009 / 282	1005 / 347
	290	CFM / WATTS	947 / 85	944 / 141	939 / 198	935 / 259	930 / 321
	450	CFM / WATTS	1714 / 332	1721 / 431	1724 / 530	1724 / 629	1720 / 728
	420	CFM / WATTS	1599 / 279	1607 / 371	1609 / 463	1609 / 556	1606 / 649
	400	CFM / WATTS	1522 / 247	1529 / 335	1532 / 422	1532 / 511	1529 / 599
	370	CFM / WATTS	1406 / 204	1412 / 285	1414 / 366	1414 / 448	1411 / 531
4.5	350	CFM / WATTS	1328 / 179	1333 / 255	1335 / 332	1334 / 410	1331 / 489
	330	CFM / WATTS	1250 / 155	1254 / 227	1254 / 300	1253 / 374	1250 / 449
	310	CFM / WATTS	1171 / 134	1173 / 201	1173 / 270	1171 / 340	1168 / 412
	290	CFM / WATTS	1091 / 115	1092 / 178	1091 / 243	1088 / 309	1084 / 377
	450	CFM / WATTS	1926 / 449	1933 / 561	1935 / 672	1934 / 784	1929 / 895
	420	CFM / WATTS	1799 / 376	1807 / 480	1809 / 584	1808 / 688	1805 / 792
	400	CFM / WATTS	1714 / 332	1721 / 431	1724 / 530	1724 / 629	1720 / 728
5.0 ^(a)	370	CFM / WATTS	1585 / 273	1592 / 364	1595 / 455	1595 / 547	1592 / 639
	350	CFM / WATTS	1498 / 238	1505 / 324	1508 / 410	1507 / 497	1504 / 585
	330	CFM / WATTS	1411 / 206	1417 / 287	1419 / 368	1418 / 450	1416 / 534
	310	CFM / WATTS	1323 / 177	1328 / 253	1330 / 330	1329 / 407	1326 / 486
	290	CFM / WATTS	1235 / 151	1239 / 222	1239 / 294	1238 / 367	1234 / 442
	450	CFM / WATTS	2135 / 590	2140 / 715	2141 / 839	2137 / 964	2131 / 1088
	420	CFM / WATTS	1996 / 493	2003 / 609	2004 / 725	2002 / 841	1997 / 956
5.0 ^(a)	400	CFM / WATTS	1903 / 435	1910 / 545	1912 / 655	1911 / 765	1906 / 875
	370	CFM / WATTS	1761 / 356	1769 / 458	1772 / 559	1771 / 661	1767 / 763
	350 ^(a)	CFM / WATTS	1666 / 310	1674 / 405	1677 / 501	1676 / 501	1673 / 694
	330	CFM / WATTS	1570 / 267	1578 / 357	1580 / 448	1580 / 538	1577 / 630
	310	CFM / WATTS	1474 / 229	1481 / 313	1483 / 398	1483 / 484	1480 / 570
	290	CFM / WATTS	1377 / 194	1383 / 273	1385 / 353	1384 / 433	1381 / 515

Airflow Tables

Table 10. S8V2C100M5P Heating Airflow

S8V2C100M5P Furnace Heating Airflow (CFM), Temp. Rise (°F), and Power (Watts) vs. External Static Pressure with Filter (iwc)								
				1st Stage Capacity = 52,300 2nd Stage Capacity = 81,200				
Heating	Airflow Setting	Target Airflow		External Static Pressure				
				0.1	0.3	0.5	0.7	0.9
Heating 1st Stage	Low	979	CFM	1014	998	981	966	950
			Temp. Rise	48	49	50	51	51
			Watts	77	139	200	261	322
	Medium Low	1080	CFM	1103	1093	1083	1073	1062
			Temp. Rise	44	44	45	45	46
			Watts	98	163	228	294	359
	Medium ^(a)	1188	CFM	1202	1190	1177	1165	1153
			Temp. Rise	41	41	41	42	42
			Watts	119	188	257	327	397
	High	1296	CFM	1332	1314	1296	1278	1260
			Temp. Rise	37	37	38	38	39
			Watts	156	229	302	376	449
Heating 2nd Stage	Low	1360	CFM	1401	1393	1385	1377	1369
			Temp. Rise	54	54	54	54	54
			Watts	164	249	334	419	503
	Medium Low	1500	CFM	1537	1523	1509	1495	1482
			Temp. Rise	49	49	49	50	50
			Watts	223	313	404	494	585
	Medium ^(a)	1650	CFM	1673	1667	1661	1654	1649
			Temp. Rise	45	45	45	45	45
			Watts	285	381	478	575	671
	High	1800	CFM	1825	1819	1812	1806	1800
			Temp. Rise	42	41	41	42	42
			Watts	371	480	588	696	805

Table 11. S8V2C100M5P Cooling Airflow

S8V2C100M5P Furnace Cooling Airflow (CFM) and Power (Watts) vs. External Static Pressure with Filter (iwc)							
Outdoor Tonnage - "Odt" (tons)	Airflow Setting - "CPC" (CFM/ton)		EXTERNAL STATIC PRESSURE (IN. W. C.)				
			0.1	0.3	0.5	0.7	0.9
2.5	450	CFM / WATTS	1120 / 108	1119 / 167	1115 / 229	1109 / 294	1101 / 360
	420	CFM / WATTS	1043 / 92	1041 / 148	1036 / 207	1030 / 268	1021 / 332
	400	CFM / WATTS	992 / 83	989 / 136	984 / 193	976 / 252	968 / 315
	370	CFM / WATTS	915 / 70	910 / 120	904 / 173	895 / 230	886 / 290
	350	CFM / WATTS	863 / 62	857 / 110	850 / 161	841 / 216	831 / 275
	330	CFM / WATTS	811 / 55	804 / 100	795 / 150	786 / 204	776 / 261
	310	CFM / WATTS	759 / 48	750 / 92	741 / 140	730 / 192	719 / 248
	290	CFM / WATTS	706 / 42	696 / 84	686 / 130	674 / 181	663 / 236
3.0	450	CFM / WATTS	1346 / 166	1348 / 236	1346 / 309	1341 / 383	1335 / 458
	420	CFM / WATTS	1256 / 140	1257 / 207	1254 / 275	1249 / 345	1243 / 417
	400	CFM / WATTS	1196 / 125	1196 / 188	1193 / 254	1187 / 321	1180 / 391
	370	CFM / WATTS	1104 / 104	1103 / 163	1099 / 225	1093 / 288	1085 / 355
	350	CFM / WATTS	1043 / 92	1041 / 148	1036 / 207	1030 / 268	1021 / 332
	330	CFM / WATTS	982 / 81	979 / 134	973 / 190	965 / 249	957 / 311
	310	CFM / WATTS	920 / 70	916 / 121	909 / 174	901 / 231	892 / 292
	290	CFM / WATTS	858 / 61	852 / 109	844 / 160	835 / 215	825 / 274
3.5	450	CFM / WATTS	1568 / 242	1571 / 324	1570 / 407	1566 / 492	1560 / 577
	420	CFM / WATTS	1465 / 204	1467 / 281	1466 / 359	1462 / 438	1456 / 519
	400	CFM / WATTS	1396 / 181	1398 / 254	1396 / 329	1392 / 405	1386 / 483
	370	CFM / WATTS	1291 / 150	1292 / 218	1290 / 287	1285 / 359	1279 / 432
	350	CFM / WATTS	1221 / 131	1221 / 196	1218 / 262	1213 / 331	1206 / 401
	330	CFM / WATTS	1150 / 114	1150 / 175	1146 / 239	1140 / 304	1133 / 372
	310	CFM / WATTS	1079 / 99	1078 / 157	1073 / 217	1067 / 280	1059 / 345
	290	CFM / WATTS	1007 / 85	1005 / 140	999 / 197	992 / 257	984 / 320

Airflow Tables

Table 11. S8V2C100M5P Cooling Airflow (continued)

S8V2C100M5P Furnace Cooling Airflow (CFM) and Power (Watts) vs. External Static Pressure with Filter (iwc)							
Outdoor Tonnage - "Odt" (tons)	Airflow Setting - "CPC" (CFM/ton)		EXTERNAL STATIC PRESSURE (IN. W. C.)				
			0.1	0.3	0.5	0.7	0.9
4.0	450	CFM / WATTS	1785 / 339	1788 / 433	1787 / 527	1784 / 623	1778 / 719
	420	CFM / WATTS	1670 / 284	1673 / 372	1672 / 460	1669 / 550	1663 / 640
	400	CFM / WATTS	1592 / 252	1595 / 335	1594 / 419	1591 / 505	1585 / 592
	370	CFM / WATTS	1475 / 207	1477 / 284	1476 / 363	1472 / 443	1466 / 524
	350	CFM / WATTS	1396 / 181	1398 / 254	1396 / 329	1392 / 405	1386 / 483
	330	CFM / WATTS	1316 / 157	1318 / 226	1315 / 297	1311 / 370	1304 / 444
	310	CFM / WATTS	1236 / 135	1237 / 200	1234 / 267	1229 / 337	1222 / 408
4.5	290	CFM / WATTS	1155 / 116	1155 / 177	1151 / 240	1146 / 306	1138 / 374
	450	CFM / WATTS	1997 / 459	2000 / 564	1998 / 671	1994 / 777	1988 / 885
	420	CFM / WATTS	1870 / 384	1873 / 482	1872 / 582	1869 / 681	1863 / 782
	400	CFM / WATTS	1785 / 339	1788 / 433	1787 / 527	1784 / 623	1778 / 719
	370	CFM / WATTS	1655 / 278	1658 / 365	1658 / 452	1654 / 541	1648 / 631
	350	CFM / WATTS	1568 / 242	1571 / 324	1570 / 407	1566 / 492	1560 / 577
	330	CFM / WATTS	1479 / 209	1482 / 286	1481 / 365	1477 / 445	1471 / 527
5.0 ^(a)	310	CFM / WATTS	1391 / 179	1393 / 252	1391 / 327	1387 / 403	1381 / 480
	290	CFM / WATTS	1301 / 153	1302 / 221	1300 / 291	1296 / 363	1289 / 437
	450	CFM / WATTS	2204 / 604	2206 / 722	2203 / 840	2198 / 958	2191 / 1077
	420	CFM / WATTS	2067 / 504	2069 / 614	2067 / 724	2063 / 835	2056 / 946
	400	CFM / WATTS	1974 / 444	1976 / 549	1975 / 653	1971 / 759	1965 / 865
	370	CFM / WATTS	1832 / 363	1835 / 460	1835 / 557	1831 / 655	1825 / 754
	350 ^(a)	CFM / WATTS	1737 / 315	1740 / 406	1739 / 498	1736 / 591	1730 / 685
	330	CFM / WATTS	1641 / 272	1644 / 358	1643 / 445	1639 / 533	1634 / 622
	310	CFM / WATTS	1543 / 232	1546 / 313	1545 / 395	1542 / 478	1536 / 563
	290	CFM / WATTS	1445 / 197	1447 / 273	1446 / 350	1442 / 428	1436 / 509

Table 12. S8V2D120M5P Heating Airflow

S8V2D120M5P Furnace Heating Airflow (CFM), Temp. Rise (°F), and Power (Watts) vs. External Static Pressure with Filter (iwc)								
				1st Stage Capacity = 67,900 2nd Stage Capacity = 98,000				
Heating	Airflow Setting	Target Airflow		External Static Pressure				
				0.1	0.3	0.5	0.7	0.9
Heating 1st Stage	Low	1155	CFM	1223	1238	1254	1270	1286
			Temp. Rise	52	51	51	50	49
			Watts	103	173	243	313	384
	Medium Low ^(a)	1340	CFM	1398	1421	1443	1466	1488
			Temp. Rise	44	44	44	43	43
			Watts	149	229	310	390	471
	Medium	1450	CFM	1496	1510	1525	1540	1555
			Temp. Rise	42	41	41	41	41
			Watts	181	264	347	430	513
	High	1540	CFM	1629	1633	1638	1642	1647
			Temp. Rise	39	38	38	38	38
			Watts	225	312	398	484	571
Heating 2nd Stage	Low	1500	CFM	1597	1603	1608	1613	1619
			Temp. Rise	56	56	56	55	55
			Watts	200	294	388	482	575
	Medium Low ^(a)	1740	CFM	1822	1832	1843	1854	1865
			Temp. Rise	50	49	49	49	48
			Watts	296	405	514	624	733
	Medium	1850	CFM	1916	1930	1944	1958	1972
			Temp. Rise	47	46	46	46	45
			Watts	366	484	602	721	839
	High	2000	CFM	2045	2064	2082	2101	2120
			Temp. Rise	44	44	43	43	42
			Watts	463	593	723	854	983

Airflow Tables

Table 13. S8V2D120M5P Cooling Airflow

S8V2D120M5P Furnace Cooling Airflow (CFM) and Power (Watts) vs. External Static Pressure with Filter (iwc)							
Outdoor Tonnage - "Odt" (tons)	Airflow Setting - "CPC" (CFM/ton)		EXTERNAL STATIC PRESSURE (IN. W. C.)				
			0.1	0.3	0.5	0.7	0.9
3.0	450	CFM / WATTS	1376 / 149	1382 / 217	1382 / 287	1378 / 359	1371 / 434
	420	CFM / WATTS	1283 / 126	1288 / 189	1286 / 255	1281 / 323	1274 / 395
	400	CFM / WATTS	1221 / 112	1225 / 172	1222 / 235	1216 / 301	1208 / 370
	370	CFM / WATTS	1126 / 93	1129 / 149	1125 / 208	1118 / 271	1108 / 337
	350	CFM / WATTS	1063 / 82	1064 / 135	1059 / 192	1051 / 252	1040 / 316
	330	CFM / WATTS	998 / 71	999 / 122	993 / 176	984 / 234	972 / 297
	310	CFM / WATTS	934 / 62	933 / 110	926 / 162	916 / 218	904 / 279
	290	CFM / WATTS	869 / 54	867 / 99	859 / 149	848 / 203	834 / 263
3.5	450	CFM / WATTS	1602 / 219	1611 / 299	1614 / 380	1613 / 463	1609 / 547
	420	CFM / WATTS	1497 / 184	1505 / 258	1506 / 334	1504 / 412	1499 / 492
	400	CFM / WATTS	1427 / 163	1433 / 234	1434 / 306	1431 / 380	1425 / 457
	370	CFM / WATTS	1319 / 134	1325 / 200	1324 / 267	1319 / 337	1312 / 409
	350	CFM / WATTS	1247 / 117	1251 / 179	1249 / 243	1244 / 310	1235 / 380
	330	CFM / WATTS	1174 / 102	1177 / 160	1174 / 221	1167 / 286	1158 / 353
	310	CFM / WATTS	1100 / 88	1102 / 143	1098 / 201	1090 / 263	1080 / 328
	290	CFM / WATTS	1025 / 76	1026 / 127	1021 / 182	1012 / 241	1001 / 304
4.0	450	CFM / WATTS	1821 / 310	1832 / 402	1838 / 495	1839 / 588	1838 / 683
	420	CFM / WATTS	1705 / 259	1715 / 344	1719 / 431	1720 / 519	1717 / 608
	400	CFM / WATTS	1627 / 228	1636 / 310	1639 / 392	1638 / 476	1635 / 561
	370	CFM / WATTS	1507 / 187	1515 / 262	1517 / 338	1515 / 416	1510 / 497
	350	CFM / WATTS	1427 / 163	1433 / 234	1434 / 306	1431 / 380	1425 / 457
	330	CFM / WATTS	1345 / 141	1351 / 207	1350 / 276	1346 / 347	1339 / 420
	310	CFM / WATTS	1262 / 121	1267 / 184	1265 / 248	1260 / 316	1252 / 386
	290	CFM / WATTS	1179 / 103	1182 / 162	1179 / 223	1173 / 287	1164 / 355
4.5	450	CFM / WATTS	2032 / 423	2045 / 528	2053 / 632	2057 / 738	2059 / 844
	420	CFM / WATTS	1907 / 352	1918 / 449	1925 / 547	1927 / 645	1928 / 744
	400	CFM / WATTS	1821 / 310	1832 / 402	1838 / 495	1839 / 588	1838 / 683
	370	CFM / WATTS	1691 / 253	1700 / 338	1704 / 423	1705 / 510	1702 / 599
	350	CFM / WATTS	1602 / 219	1611 / 299	1614 / 380	1613 / 463	1609 / 547
	330	CFM / WATTS	1512 / 189	1520 / 264	1522 / 341	1520 / 419	1515 / 499
	310	CFM / WATTS	1421 / 161	1428 / 232	1429 / 304	1426 / 378	1420 / 455
	290	CFM / WATTS	1329 / 137	1335 / 203	1334 / 271	1330 / 341	1323 / 414
5.0 ^(a)	450	CFM / WATTS	2236 / 561	2250 / 678	2260 / 796	2266 / 913	2270 / 1031
	420	CFM / WATTS	2101 / 466	2114 / 575	2123 / 684	2128 / 793	2130 / 903
	400	CFM / WATTS	2009 / 409	2022 / 512	2029 / 616	2033 / 720	2035 / 825
	370	CFM / WATTS	1869 / 333	1880 / 428	1886 / 523	1888 / 619	1888 / 717
	350 ^(a)	CFM / WATTS	1773 / 288	1784 / 377	1789 / 467	1790 / 558	1788 / 651
	330	CFM / WATTS	1676 / 247	1685 / 331	1689 / 416	1689 / 502	1687 / 590
	310	CFM / WATTS	1577 / 210	1586 / 289	1588 / 369	1587 / 450	1583 / 533
	290	CFM / WATTS	1477 / 178	1485 / 251	1486 / 326	1483 / 403	1478 / 482

^(a) Factory Setting (applies to all Airflow Tables)

Wiring Diagrams

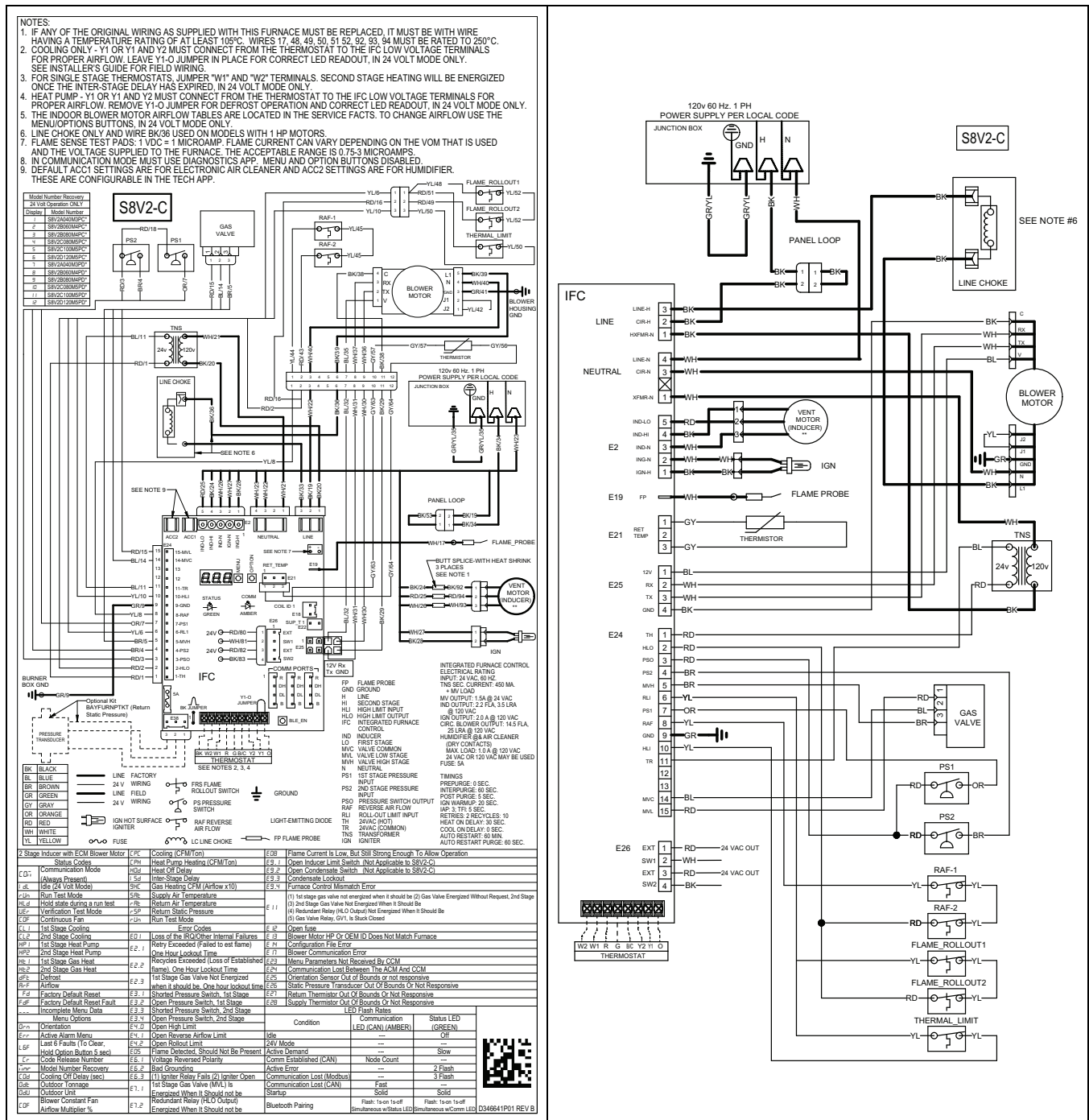

Electrical Connections

Make wiring connections to the unit as indicated on enclosed wiring diagram. As with all gas appliances using electrical power, this furnace shall be connected into a permanently live electric circuit. It is recommended that furnace be provided with a separate "circuit protection device" electric circuit. The furnace must be electrically grounded in accordance with local codes or in the absence of local codes with the National Electrical Code, ANSI/NFPA 70, if an external electrical source is utilized. **The integrated furnace control is polarity sensitive.** The hot leg of the 120V power supply must be connected to the black power lead as indicated on the wiring diagram. Refer to the Wiring Diagram section in this document and unit wiring diagram attached to furnace.

24V Field Wiring

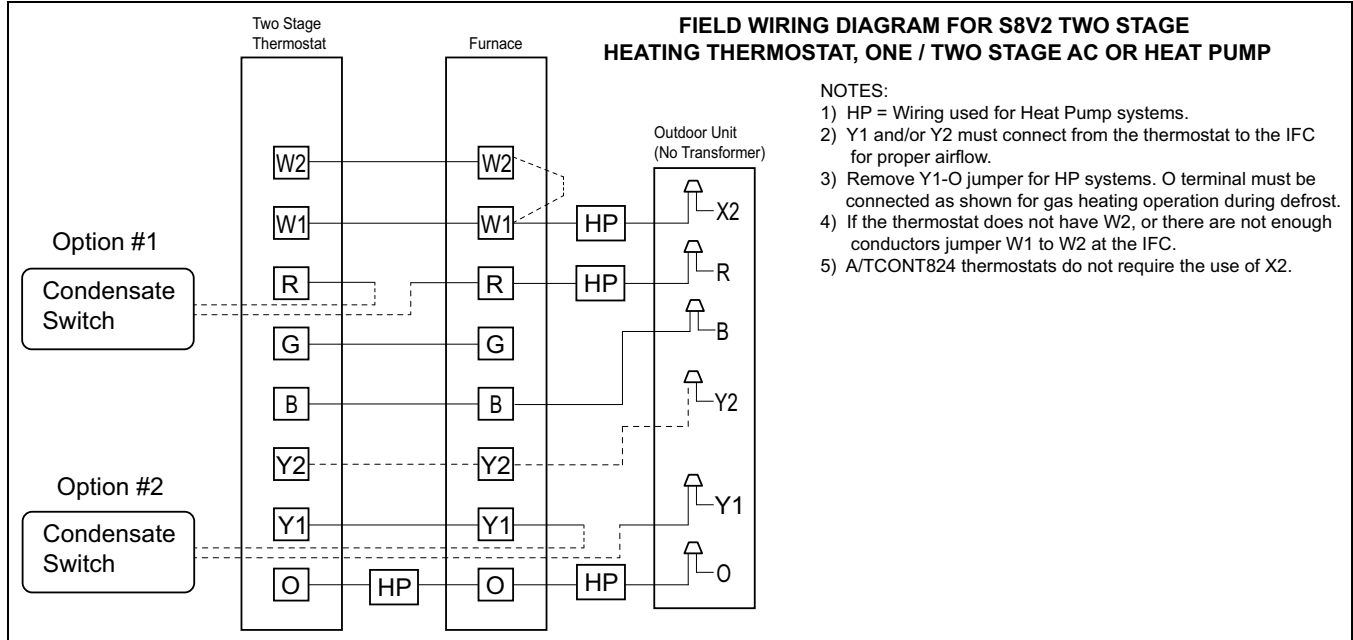

1. Secure the sheathed wiring to the IFC using the factory supplied wire ties.

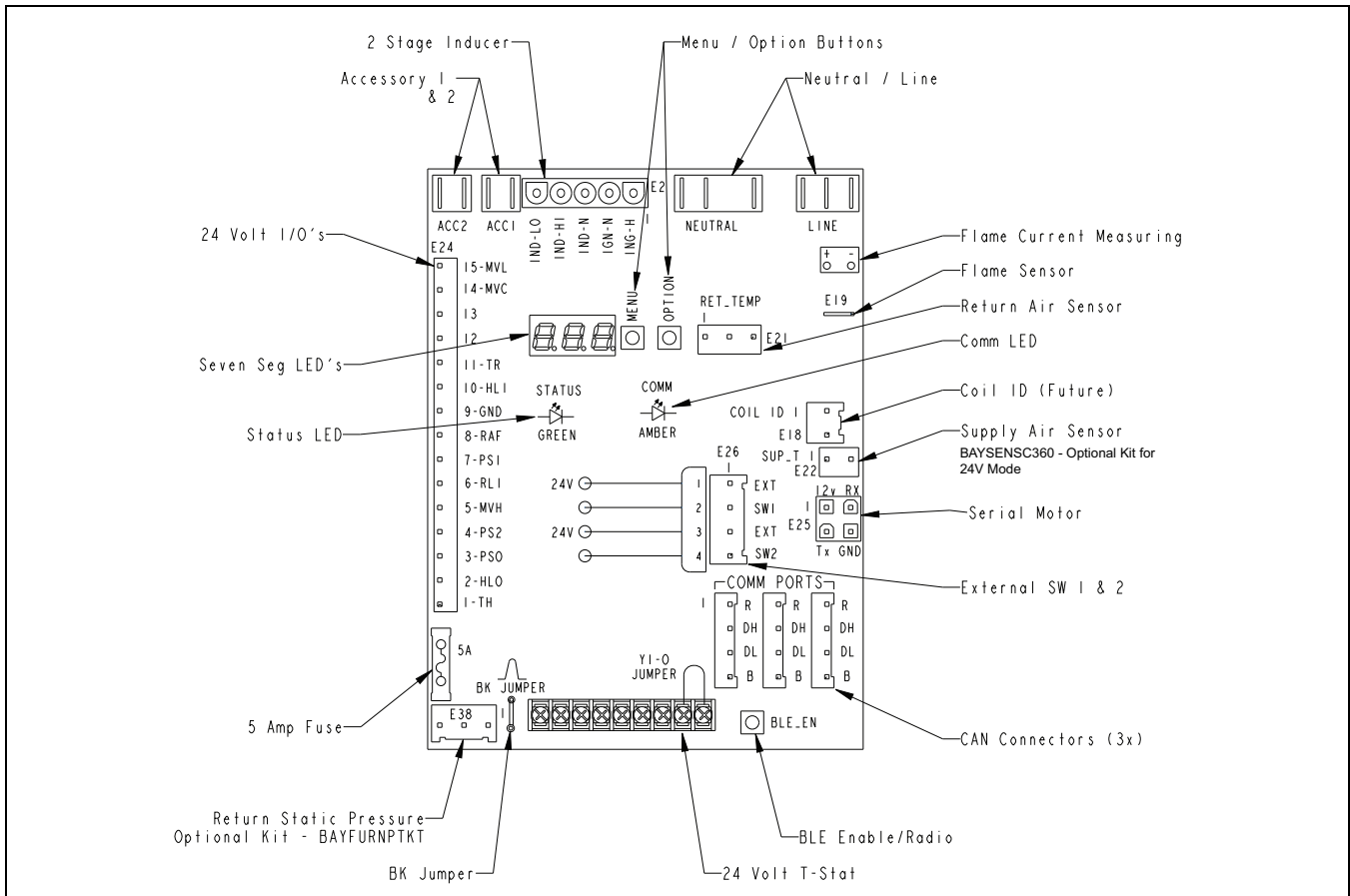

2. Mount Supply Air Temperature Sensor

The Supply Air Sensor (BAYSENSC360) must be mounted on the leaving side of the cooling coil, or the maximum distance allowed by the wire length on a furnace only application. Testing has shown the left side of the plenum delivers the best average temperature. If the left side cannot be used, take several readings to determine the best place to mount the sensor for your application.

The Supply Air Sensor plugs into connector E22 of the IFC (See IFC layout). In the Diagnostic App, this sensor is defaulted OFF and must be configured to ON.

Note: Supply Air Temp Sensor (SAT) is used in Link Communicating mode and is optional in 24 volt mode.

Note: Supply Air Temp Sensor (SAT) ships with SC360 System Controller.

Note: Supply Air Sensor kit is BAYSENSC360.

Note: The return air sensor is located within the blower wiring harness, behind the blower panel. In the Diagnostic App, this sensor is defaulted ON.

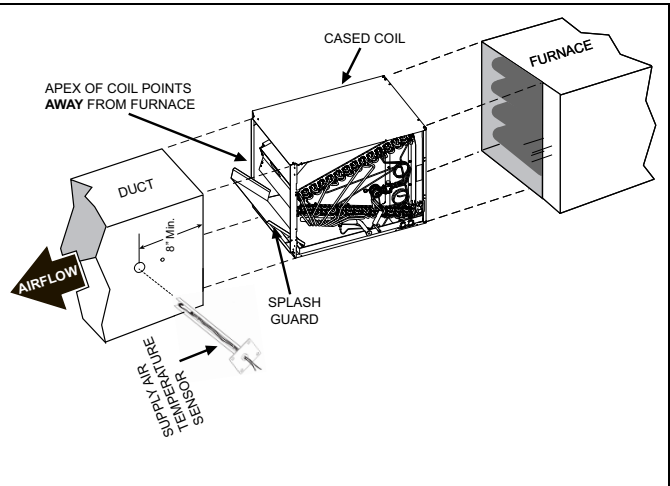

Electrical Connections

Table 14. Low Voltage Maximum Wire Length

<p>The Low Voltage Maximum Wire Length table defines the size and combined total maximum length of the low voltage wiring from the outdoor unit, to the indoor unit, and to the thermostat.</p> <p>Note: The use of color coded low voltage wire is recommended to simplify connections between the outdoor unit, the control, and the indoor unit.</p>	Control Wire – Communicating	
	WIRE SIZE	MAX. WIRE LENGTH
	18 AWG	500 FT. Combined
	Control Wire – 24 Volt	
	WIRE SIZE	MAX. WIRE LENGTH
18 AWG	100 FT. Combined	

Table 15. Link Communicating Low Voltage Wire Connectors

<p>Link mode uses simple connectors for low voltage connections. These connections are color coded which makes the installation easier and quicker.</p> <table border="1" style="margin: 10px auto;"> <thead> <tr> <th colspan="2">Wire Colors</th> </tr> </thead> <tbody> <tr> <td>R</td> <td>Red</td> </tr> <tr> <td>DH</td> <td>White</td> </tr> <tr> <td>DL</td> <td>Green</td> </tr> <tr> <td>B</td> <td>Blue</td> </tr> </tbody> </table> <p>Do the following to make the connections from the actual thermostat wire to the connector.</p> <p>Note: These connectors are necessary at the communicating outdoor unit, communicating indoor unit, distribution board(s), system controller and communicating accessories.</p> <ol style="list-style-type: none"> Strip the Red, White, Green and Blue thermostat wires back 1/4". Insert the wires into the connector in the correctly colored locations. When you feel it release, allow each wire to slide in further. Pull back on the wires individually and slightly and check if the wires are seated properly. If each wire does not pull out for all four wires, the connection is complete. Connectors are ONE TIME USE. If a 18 ga. Thermostat wire gets broken off inside of the connector, the connector will need replaced. Wire colors are for illustration purposes only. If using a different color, ensure it lands at the correct terminal throughout all of the communicating control wiring. <p>Connect the CAN connector into the male coupling on the low voltage harness at the Outdoor unit.</p> <p>This furnace has three dedicated CAN connectors on the Integrated Furnace Control (IFC). In Link communicating mode, all of them are in the communicating loop. It does not matter which connector is used for the Thermostat, System Controller (HUB), or Outdoor unit. Link accessories can be connected to the Distribution Board if needed.</p>	Wire Colors		R	Red	DH	White	DL	Green	B	Blue	<p style="text-align: center;">CAN Connector</p> <p style="text-align: center;">Strip the control wire back- 1/4"</p> <p>Note: For use with 18 ga. solid core thermostat wire.</p>
Wire Colors											
R	Red										
DH	White										
DL	Green										
B	Blue										

Table 16. Link Communicating Low Voltage Hook-Up Diagrams

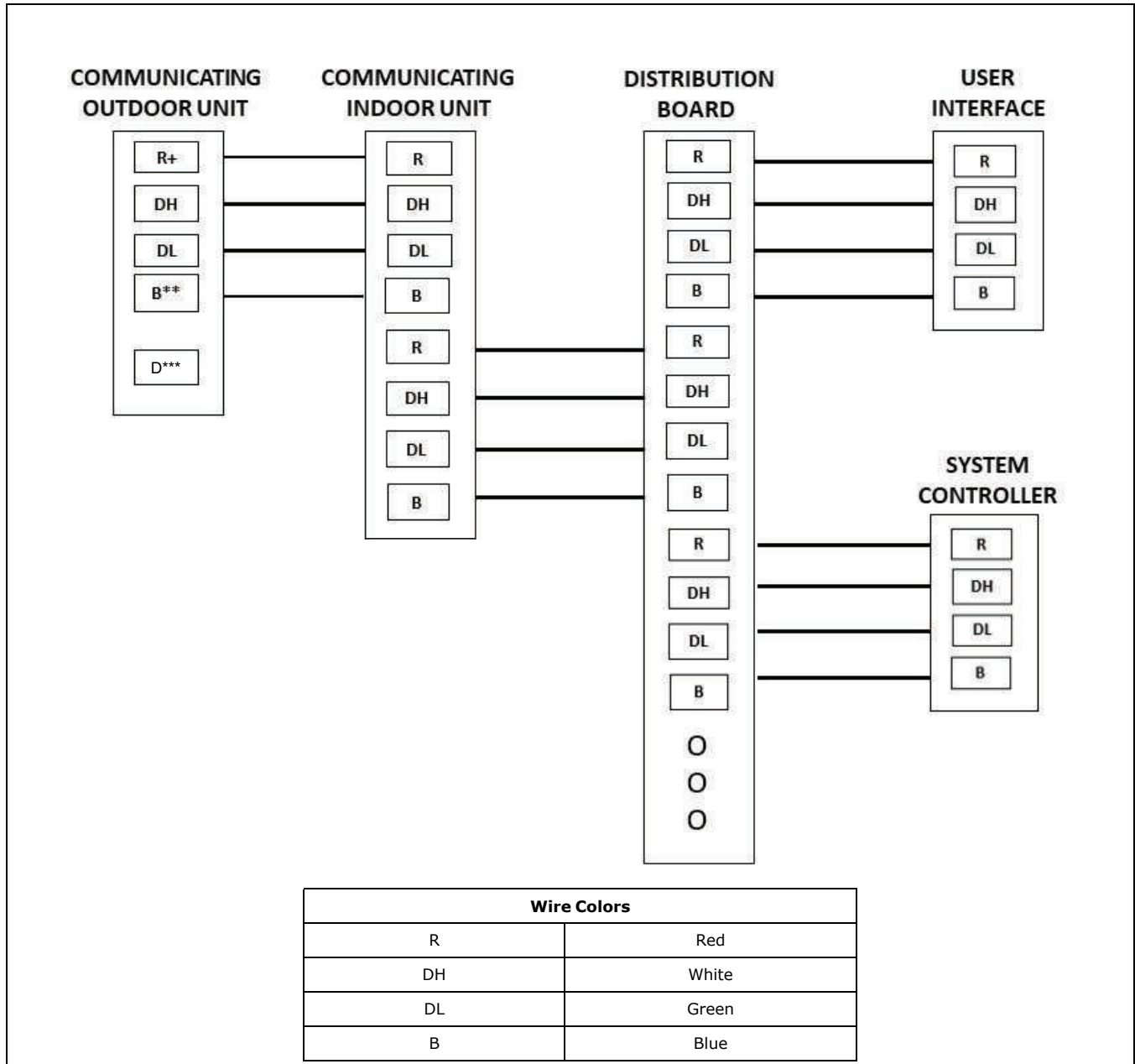

Note:

- + —R connection to the outdoor unit is required only in applications utilizing an outdoor loadshed device or when using SmartCharge.
- ** —B connection to the outdoor unit is optional for 2 wire outdoor applications, but is recommended in other applications.
- *** —DATA (Brown) wire only used in Clii mode.
- Wire colors are for illustration purposes only. If using a different color, ensure it lands at the correct terminal throughout all of the communicating control wiring.
- Drawing is for reference only - wiring can be done many different ways.

Electrical Connections

External Switches and Accessories

When connecting a humidifier or electronic air cleaner to the furnace, use ACC1 for the air cleaner and ACC2 for the humidifier.

- Accessory 1 and 2 are dry contacts need source voltage from the accessory.
- External switches 1 and 2 have 24VAC source voltage and are to be connected to Normally Closed (NC) contacts on the device, i.e smoke detector.

Note: In Link Communicating mode, Accessories and External Switches can be configured in the UX360 User Interface or Diagnostics Mobile app.

Note: In 24V mode, Accessories and External Switches can be configured in the UX360 User Interface or Diagnostics Mobile app.

Note: DO NOT USE the Condensate Cooling option in 24V mode of operation. See the 24V Field Wiring Diagram section.

Accessory
1 & 2

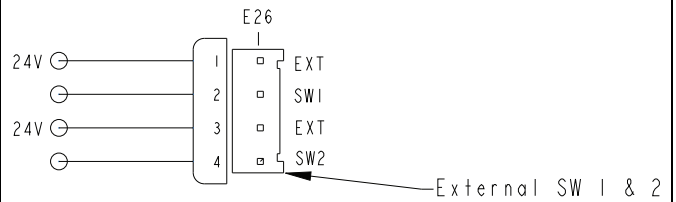
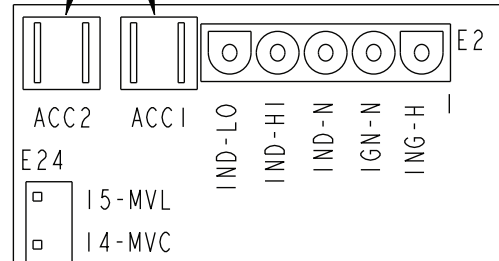

Outline Drawing

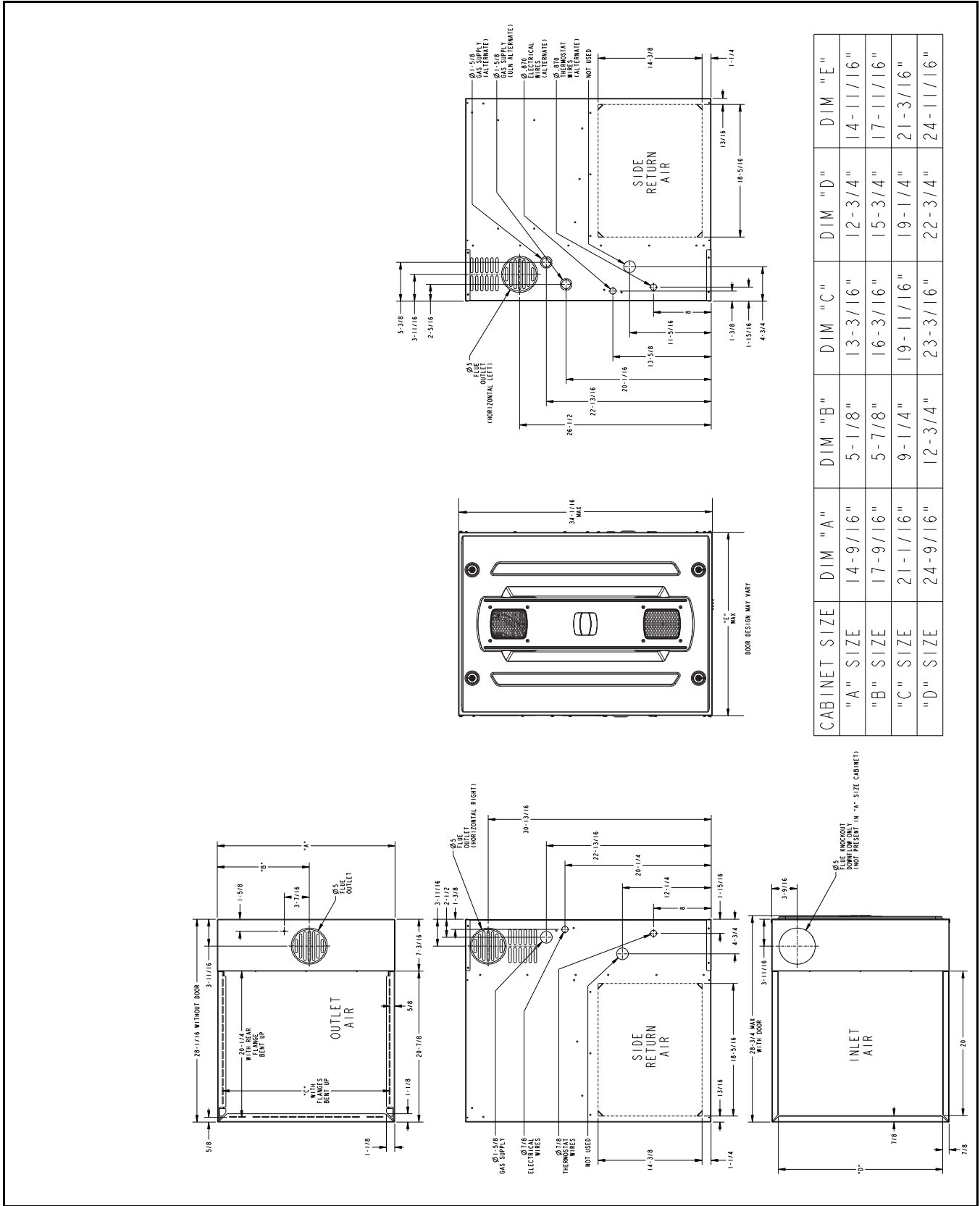

CABINET SIZE	DIM "A"	DIM "B"	DIM "C"	DIM "D"	DIM "E"
"A" SIZE	14-9/16"	5-1/8"	13-3/16"	12-3/4"	14-11/16"
"B" SIZE	17-9/16"	5-7/8"	16-3/16"	15-3/4"	17-11/16"
"C" SIZE	21-1/16"	9-1/4"	19-11/16"	19-1/4"	21-3/16"
"D" SIZE	24-9/16"	12-3/4"	23-3/16"	22-3/4"	24-11/16"

American Standard[®]
HEATING & AIR CONDITIONING

About American Standard Heating and Air Conditioning

American Standard has been creating comfortable and affordable living environments for more than a century. For more information, please visit www.americanstandardair.com.



The manufacturer has a policy of continuous data improvement and it reserves the right to change design and specifications without notice. We are committed to using environmentally conscious print practices.