

Installation Guide

Other Installation Guides may be necessary, based on system configuration.

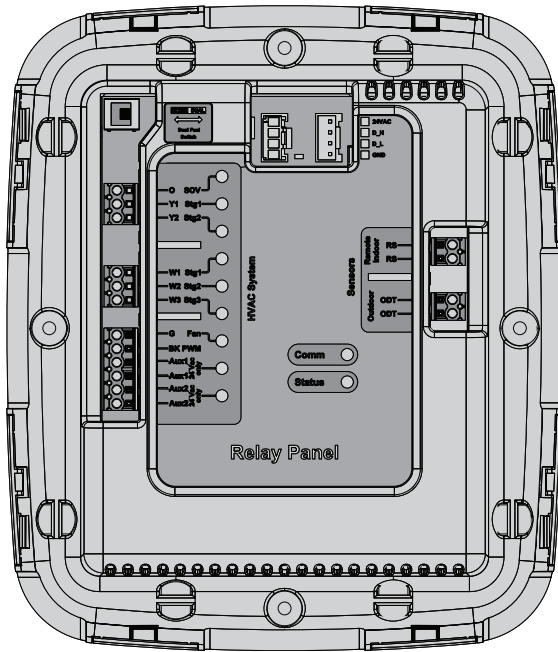

BAC24VRPA252UA

- | | |
|----------|--|
| 1 | Control (required) LINK360 |
| 2 | Relay Panel
For use with Link Communicating Control and 24V Indoor Systems |

ALL phases of this installation must comply with NATIONAL, STATE AND LOCAL CODES

IMPORTANT — This Document is customer property and is to remain with this unit.

These instructions do not cover all variations in systems or provide for every possible contingency to be met in connection with the installation. Should further information be desired or should particular problems arise which are not covered sufficiently for the purchaser's purposes, the matter should be referred to your installing dealer or local distributor.

Section 1. Safety

⚠ WARNING

This information is intended for use by individuals possessing adequate backgrounds of electrical and mechanical experience. Any attempt to repair a central air conditioning product may result in personal injury and/or property damage. The manufacturer or seller cannot be responsible for the interpretation of this information, nor can it assume any liability in connection with its use.

⚠ WARNING

LIVE ELECTRICAL COMPONENTS!
During installation, testing, servicing, and troubleshooting of this product, it may be necessary to work with live electrical components. Failure to follow all electrical safety precautions when exposed to live electrical components could result in death or serious injury.

Table of Contents

Section 1. Safety	1
Section 2. General Information	2
Section 3. Installation	3
Section 4. Terminal Locations and ID ..	6
Section 5. Field Wiring Diagrams	8
Section 6. LED Indicators	14
Section 7. Relay Panel Configuration ..	15
Section 8. Troubleshooting	17

Section 2. General Information

2.1 Overview

The Relay Panel is a wall mounted low voltage panel that enables Link communicating controls to operate with 24 VAC indoor HVAC equipment and up to two pieces of auxiliary equipment. Four wires are required from the control to the Relay Panel.

For specific wiring applications, see Field Wiring Diagrams.

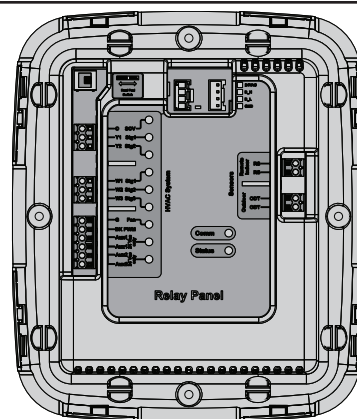

2.2 Contents in Box

The following parts are included in product model BAC24VRPA252UA:

- 1 - Relay Panel
- 4 - Mounting screws/anchors
- 4 - Wire ties
- 1 - Installation Guide
- 1 - CAN Wire Harness
- 2 - CAN Connector Pack

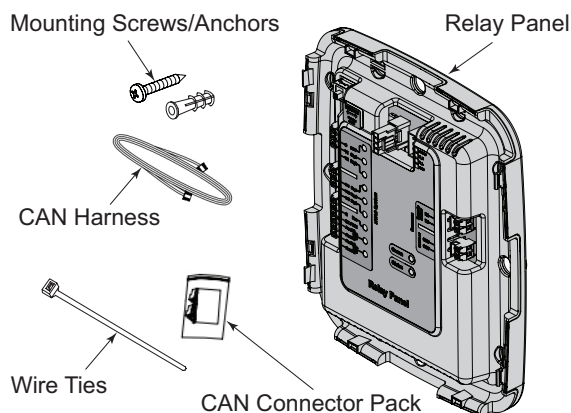

2.3 Optional Accessories

Sensor	Description
ZZSENSAL0400AA	Indoor Temperature Sensor

2.4 Specifications

Specification	Description
Product Model:	BAC24VRPA252UA
Product:	Relay Panel for use with 24V indoor systems
Size:	8.0" width x 9.3" height x 1.9" depth
Storage Temperature:	-40° to 175°F, 5% - 95% RH non-condensing
Operating Temperature:	-40° to 150°F, 5% - 95% RH non-condensing
Input Power:	24 VAC from HVAC System (Range: 18-32 VAC)
Power Consumption:	4VA* (See the following table for system transformer sizing guidelines.)
Wire usage:	Minimum 18 gauge NEC approved control wiring
HVAC System Type Compatible:	Standard (gas/electric), Heat Pump, Dual Fuel
Multistage System Compatible:	Standard HVAC Systems: 3-stage heating, 2-stage cooling (Future) Heat Pump Systems: 5-stage heating (2-compressor (Future), 3 aux heat), 2-stage cooling (Future)
LEDs:	10 green, 1 amber
Communications:	Controller Area Network (CAN) Bus
AUX Contacts:	Dry contacts, 18–30 VAC, 2A max

2.5 System Transformer Sizing Guidelines

Outdoor Unit Type	Indoor Unit Type			
	Comm Furnace	Comm Air Handler	24V Furnace	24V Air Handler
	Minimum Indoor 24V Control Power Transformer Size, (VA*)			
Communicating Heat Pump	40	40	40	40
Communicating Air Conditioner	35	40	35	40

***Note:** The VA rating of all 24V field install accessories must be added to the above for properly sizing the indoor unit control transformer, or the accessories must be powered separately.

Section 3. Installation

Unit Location Considerations

The unit's rugged design allows installation in closet, attic or other non-condensing locations free from obstructions or other hazards.

1 Mark Mounting Location

Mark four holes on the wall using the base as a template. A level may be used to ensure accuracy.

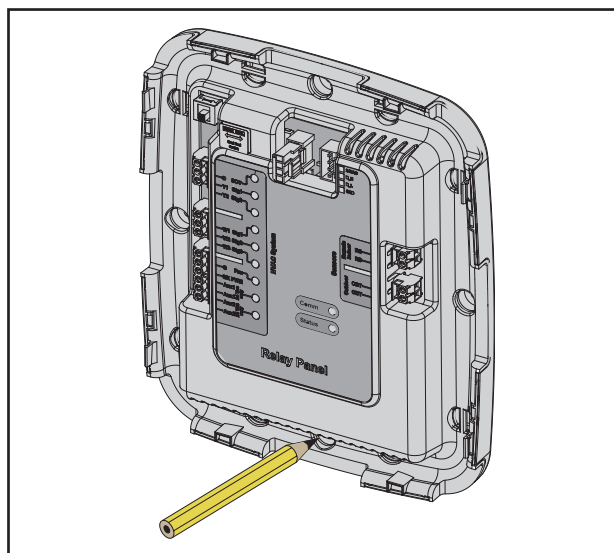

2 Mount Panel

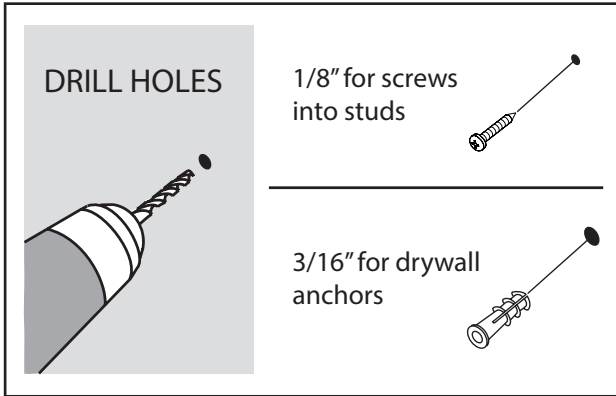

Mounting to studs: Drill 1/8" pilot holes in the four locations marked above.

Mounting to drywall:

If mounting to drywall with no studs behind it, enlarge pilot holes to 3/16" for anchors (included with the relay panel).

Gently tap anchors into the holes.

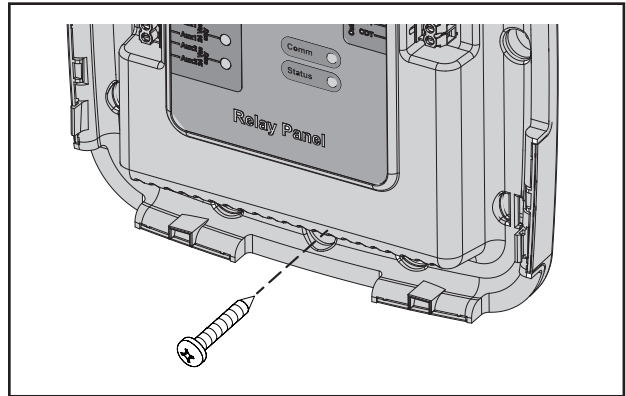

Attach base to wall using four screws provided. Do not overtighten.

3 General Wiring Information

⚠ WARNING

LIVE ELECTRICAL COMPONENTS!
During installation, testing, servicing, and troubleshooting of this product, it may be necessary to work with live electrical components. Failure to follow all electrical safety precautions when exposed to live electrical components could result in death or serious injury.

Necessary wire lengths should be considered when determining wire routing.

⚠ CAUTION

EQUIPMENT DAMAGE HAZARD!
Improper wiring can lead to equipment damage. Follow the terminal connection information carefully to ensure the control is wired properly. After wires are secure, bare wires **MUST NOT** touch each other. See the Field Wiring Diagrams for specific system applications.

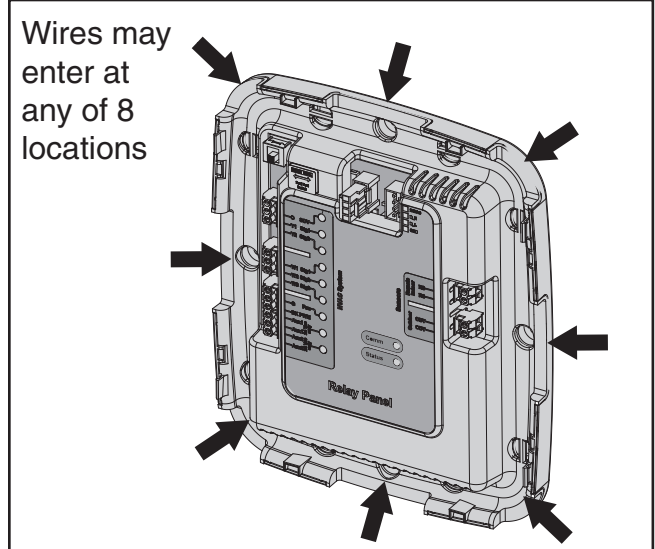

4 Routing Wires

Run wires within the recessed wire “raceway”. Be sure there is ample length to reach the connectors.

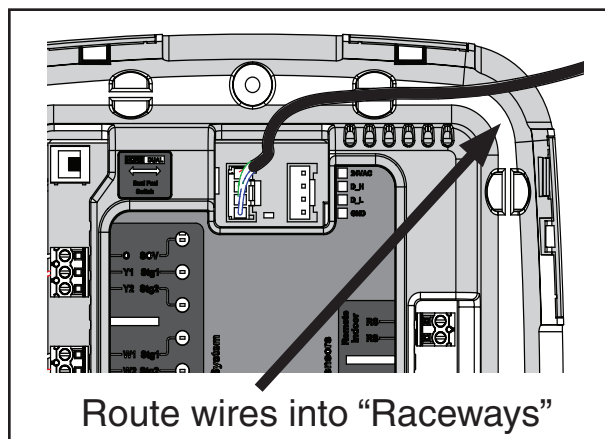

Route wires into “Raceways”

5 Attaching Wires

Using 1/8” blade screwdriver, attach all wires securely to the proper terminals on the Relay Panel.

Refer to the following section for detailed terminal information.

(See the Field Wiring Diagrams section for common system configurations.)

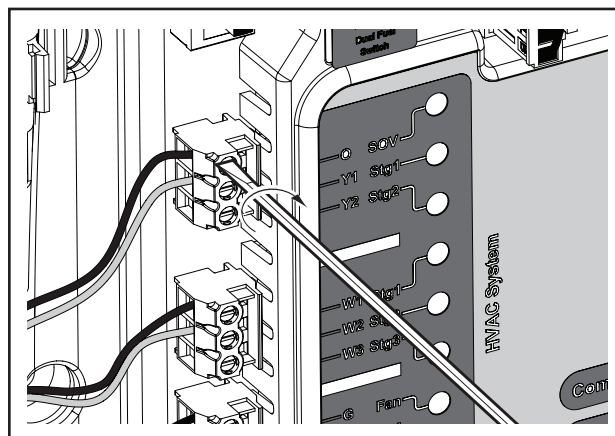

6 Securing Wires

Secure all wires with the supplied wire ties to ensure that wires are kept in place and not strained.

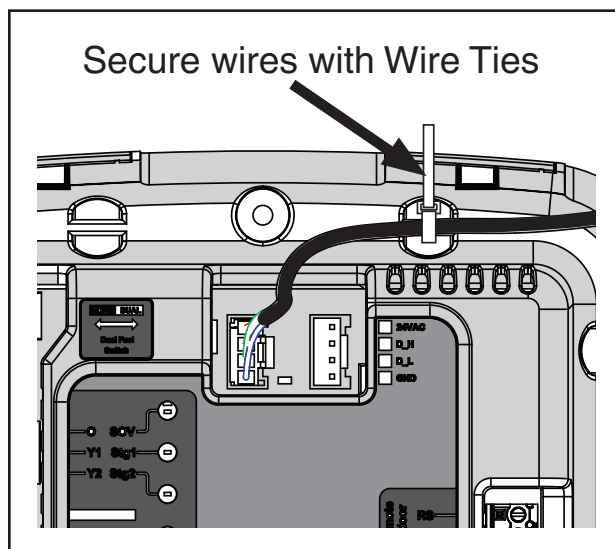

Secure wires with Wire Ties

Section 4. Terminal Locations and ID

Refer to the following diagrams for descriptions of each terminal.

KEY	Terminal Identification
(A)	Dual Fuel Switch
(B)	Link CAN Bus + 24VAC Input
(C)	Optional Sensors
(D)	HVAC System

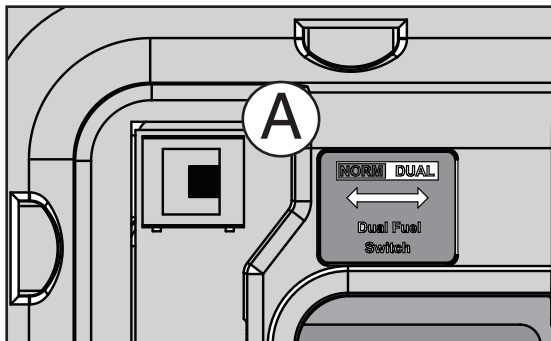
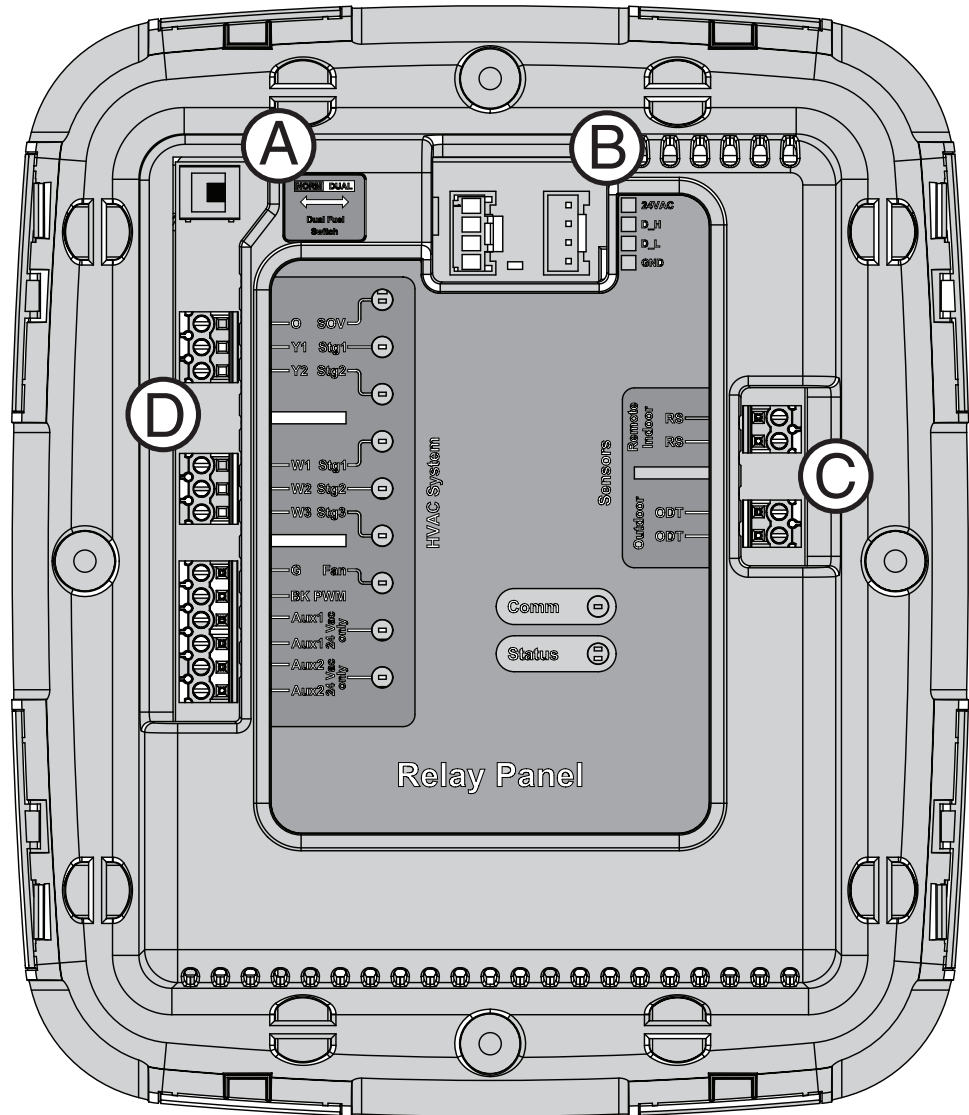

(A) Dual Fuel Switch	
Switch Position	Description
NORM	For HP or conventional Heat/Cool systems.
DUAL	For dual fuel systems.

This switch ships in the NORM position by default. Refer to the following section for complete Field Wiring Diagrams.

For convenience, you may record the color of each wire used in the blanks provided.

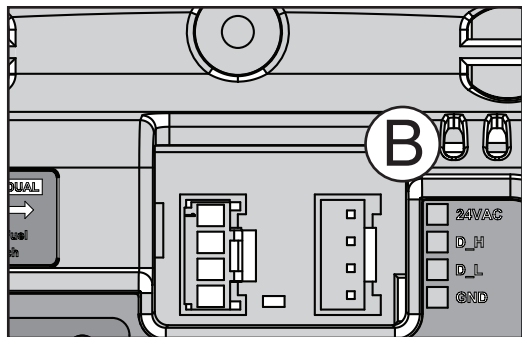

B Thermostat and Indoor Unit Connections

Terminal Name	Description	Color Used:
R - Hot	24 V hot	
DH - Data	Data High	
DL - Data	Data Low	
B - Com	24 V common	

Note: R & B must receive 24 volts from the indoor unit transformer.

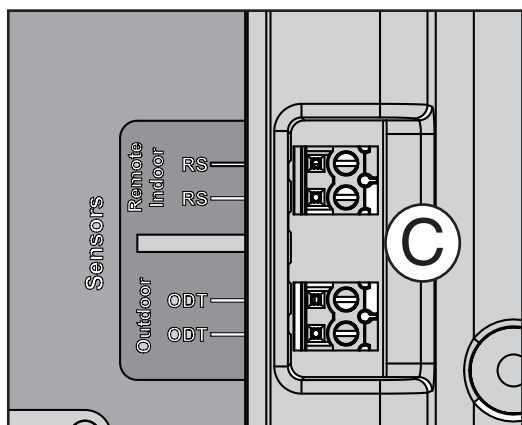

C Optional Remote Sensor Connections

Terminal Name	Description	Color Used:
Remote Indoor	RS	Remote Indoor temp sensor ZZSENSAL0400AA
	RS	
Outdoor	ODT	① Outdoor temp sensor BAYSEN01ATEMPA
	ODT	

Note: The Relay Panel uses 5 VDC to obtain temperature feedback from remote sensors. Do not run these sensors in a wiring bundle that contains 24 volts AC. See remote sensor literature for troubleshooting.

① The outdoor temperature sensor terminals are not used at this time.

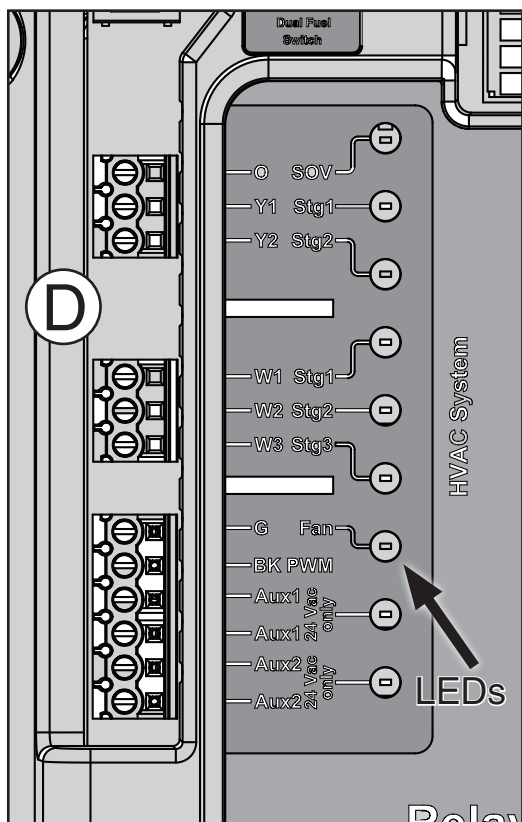

D HVAC System Connections

Terminal Name	Description	Color Used:
O - SOV ①	Switch Over Valve	
Y1 - Stg1 ①	First Stage Compressor	
Y2 - Stg2 ①	Second Stage Compressor	
W1 - Stg1	First Stage ID Heating	
W2 - Stg2	Second Stage ID Heating	
W3 - Stg3	Third Stage ID Heating	
G - Fan	Indoor Blower	
BK - PWM	PWM Signal for indoor blower modulation	
Aux 1*	Dehumidifier/Ventilation	---
Aux 1*	Dehumidifier/Ventilation	---
Aux 2*	Dehumidifier/Ventilation	---
Aux 2*	Dehumidifier/Ventilation	---

***Note:** Aux terminals are dry contacts only. Input voltage will need to be supplied. Refer to Auxiliary Equipment's installer's guide. If the output of these contacts is being used as an input to a non electro-mechanical device, a field-supplied 10K Ohm resistor should be placed between the top terminal of each pair of contacts and the Common (B) terminal of the Relay Panel.

① Terminals O, Y1 and Y2 are not used at this time.

Section 5. Field Wiring Diagrams

Diagram 1 - Link Communicating VS Heat Pump or AC w/ Non Communicating S9V2* Furnace

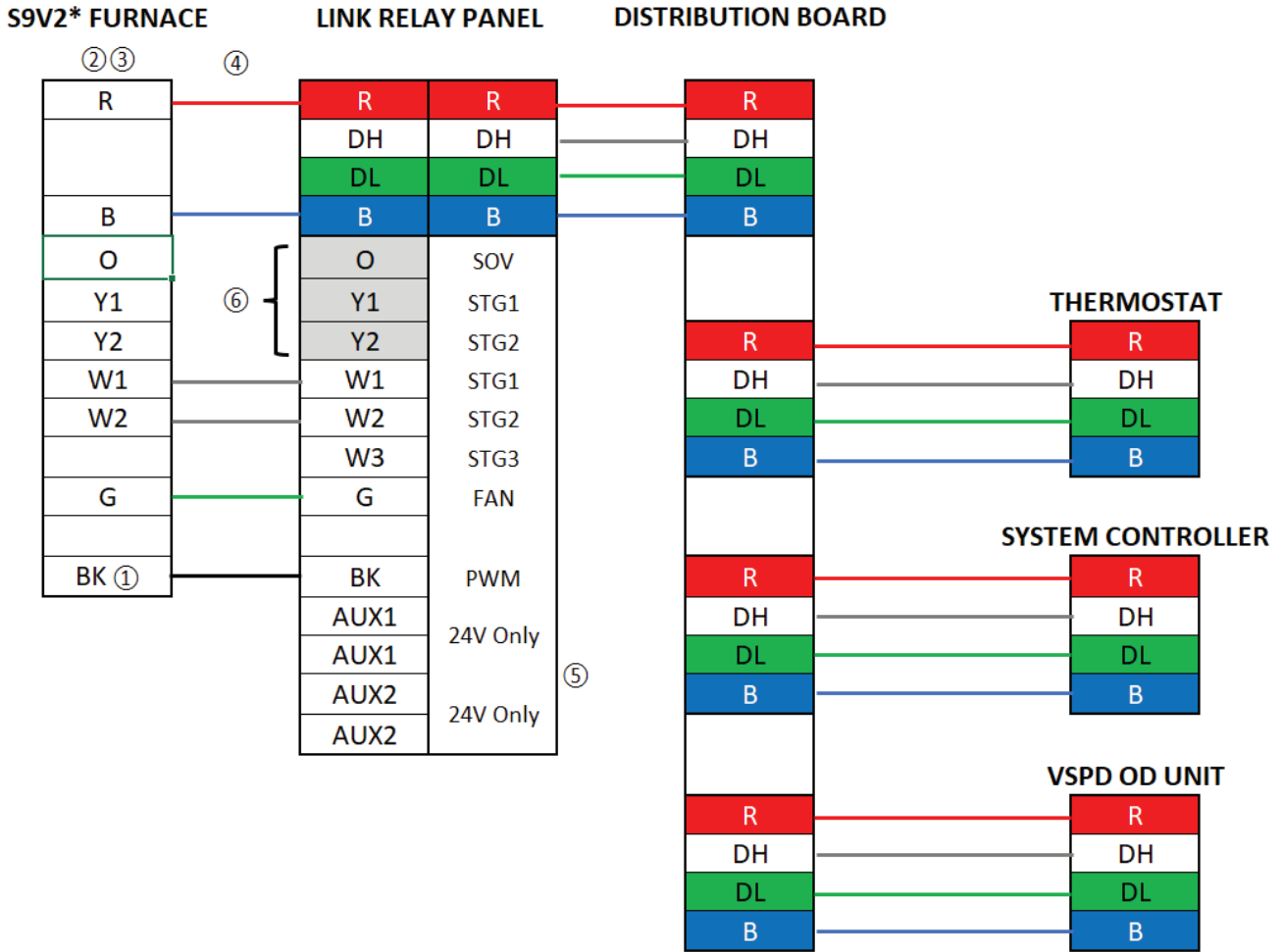

Notes:

1. Cut the BK jumper on the IFC and connect wiring per the diagram.
2. CFM/Ton must be set to 400.
3. Furnace LED's will display "CoF", continuous airflow during compressor operation.
4. Wire condensate switch in series with R to the Relay Panel.
5. See note on page 7 regarding Aux terminals.
6. Terminals O, Y1 and Y2 are not used.

Diagram 2 - Link Communicating VS Heat Pump or AC w/ Non Communicating L8V1 Furnace

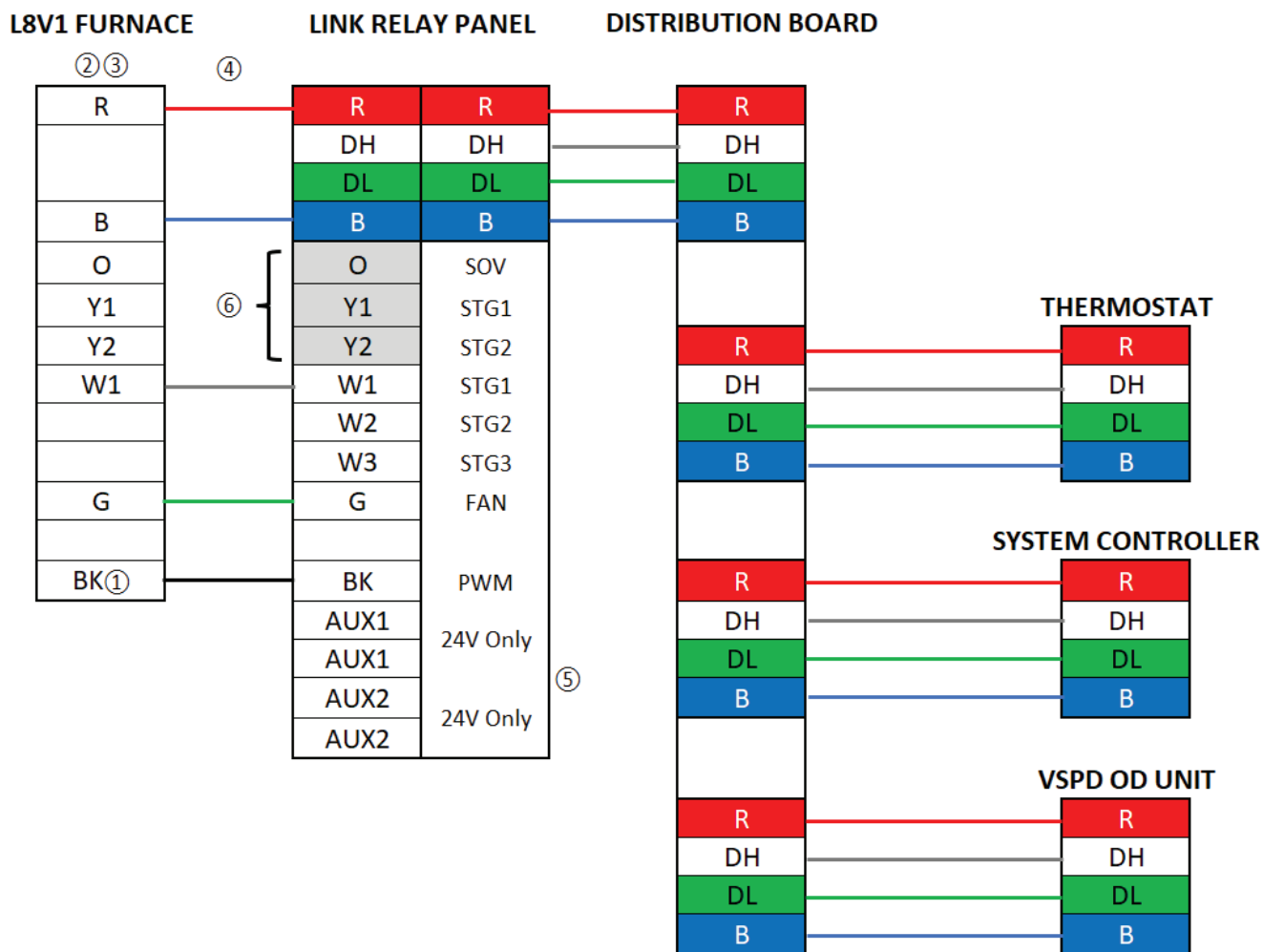

Notes:

1. Cut the BK jumper on the IFC and connect wiring per the diagram.
2. CFM/Ton must be set to 400 (CPC and CPH).
3. Furnace LED's will display "CoF", continuous airflow during compressor operation.
4. Wire condensate switch in series with R to the Relay Panel.
5. See note on page 7 regarding Aux terminals.
6. Terminals O, Y1 and Y2 are not used.

Diagram 3 - Link Communicating VS Heat Pump or AC w/*UD2* - *DD2*-ACV Furnace in 24V Mode

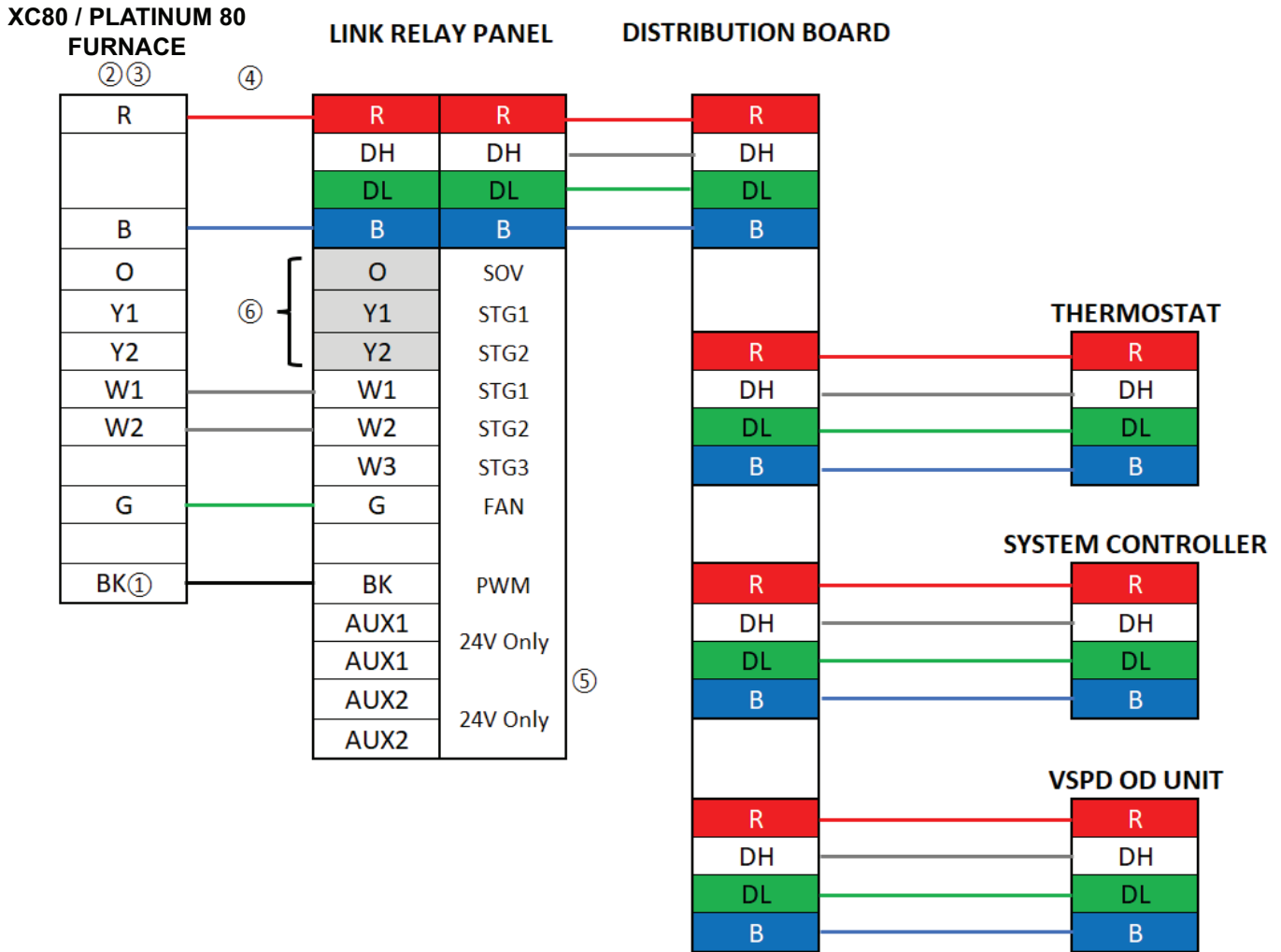

Notes:

1. Cut the BK jumper on the IFC and connect wiring per the diagram.
2. CFM/Ton must be set to 400.
3. Display will read continuous fan during compressor operation.
4. Wire condensate switch in series with R to the Relay Panel.
5. See note on page 7 regarding Aux terminals.
6. Terminals O, Y1 and Y2 are not used.

Diagram 4 - Link Communicating VS Heat Pump or AC w/*UD2* - *DD2* Furnace

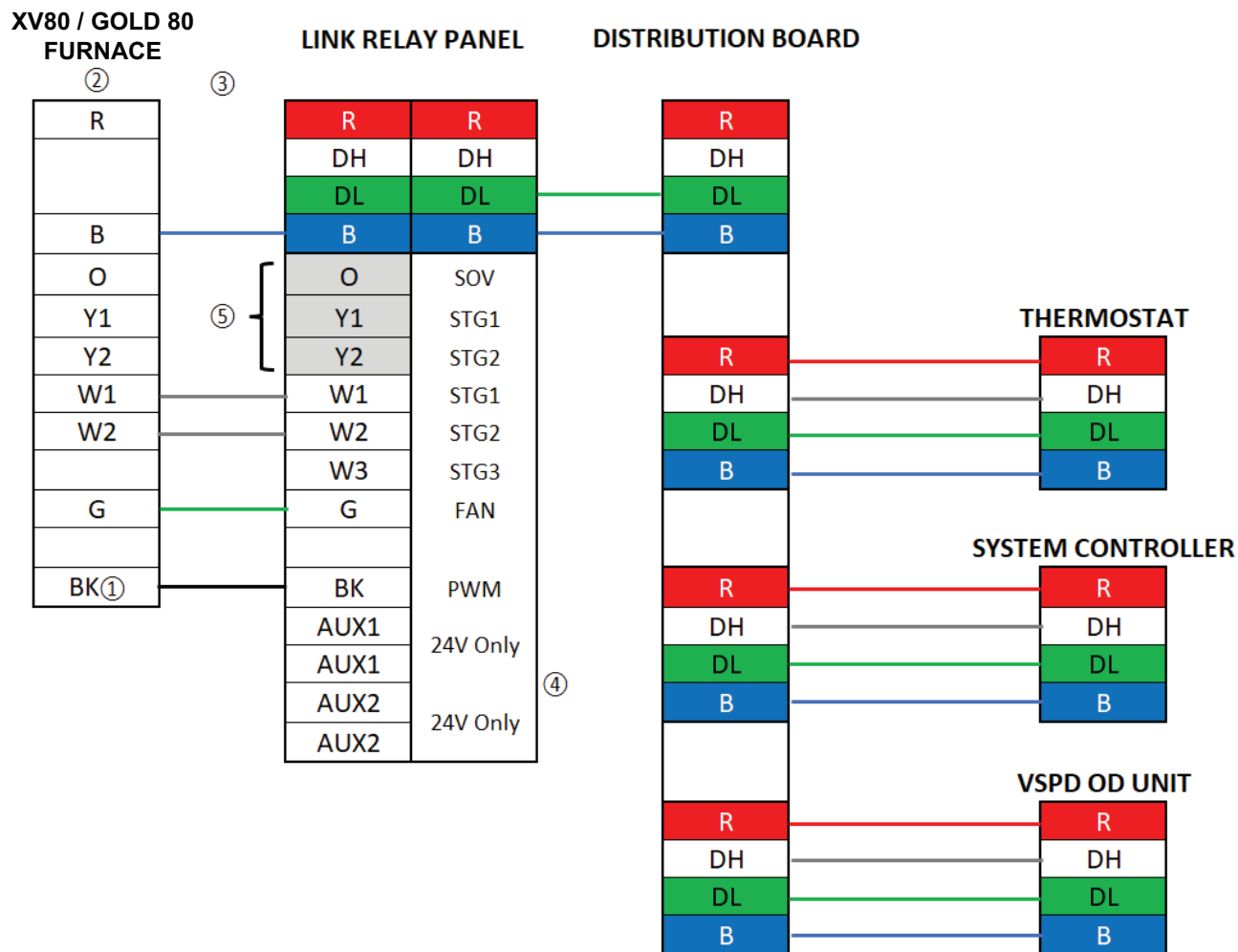

Notes:

1. Cut the BK jumper on the IFC and set Dip Switches S5-1 to ON and S5-2 to OFF, then connect the BK wiring per the diagram.
2. CFM/Ton must be set to 400 using Dip Switch S3-1 to 4 based on OD Unit Tonnage.
3. Wire condensate switch in series with R to the Relay Panel.
4. See note on page 7 regarding Aux terminals.
5. Terminals O, Y1 and Y2 are not used.

Diagram 5 - Link Communicating VS Heat Pump or AC w/ Non Communicating P0V0* Modular Blower

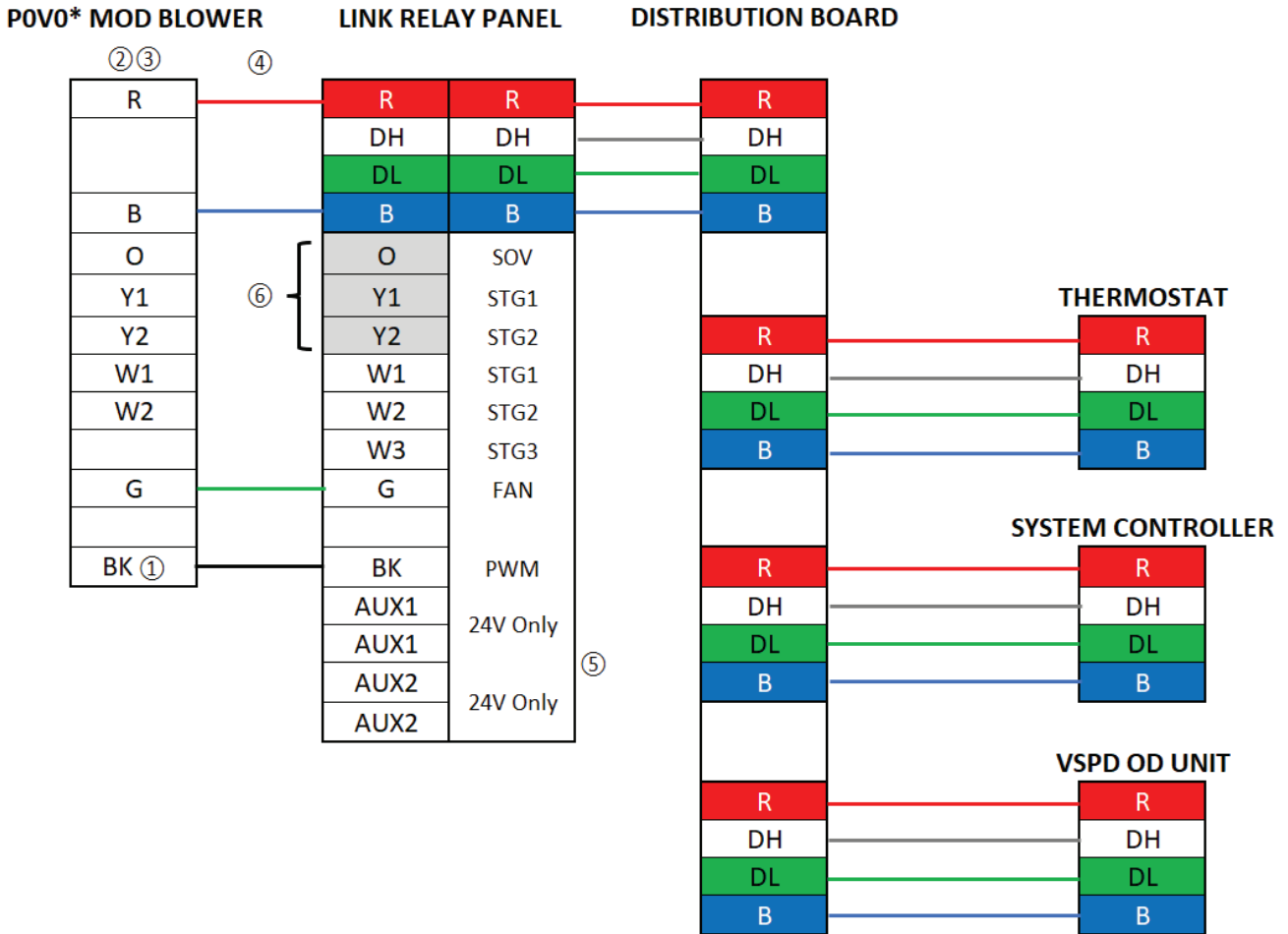

Notes:

1. Cut the BK jumper on the IFC and connect wiring per the diagram.
2. CFM/Ton must be set to 400.
3. Modular blower LED's will display "CoF", continuous airflow during compressor operation.
4. Wire condensate switch in series with R to the Relay Panel.
5. See note on page 7 regarding Aux terminals.
6. Terminals O, Y1 and Y2 are not used.

Diagram 6 - Link Communicating VS Heat Pump or AC w/ TEM6 or TEM8 in 24V Mode

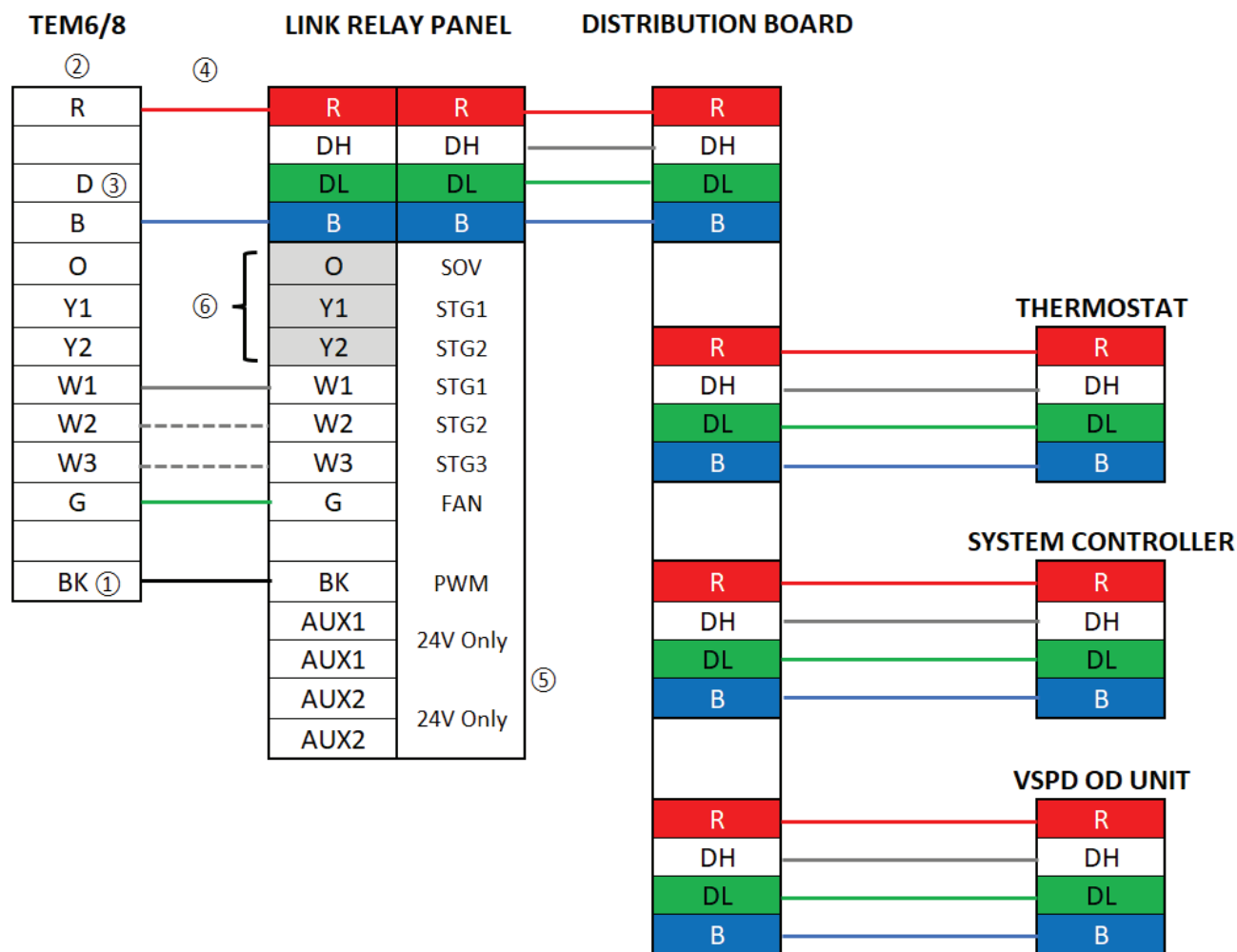

Notes:

1. Cut the BK jumper on the IFC and connect wiring per the diagram.
2. CFM/Ton must be set to 400 or the closest available setting.
3. D wiring is on TEM8 only(Do not use).
4. Wire condensate switch in series with R to the Relay Panel.
5. See note on page 7 regarding Aux terminals.
6. Terminals O, Y1 and Y2 are not used.

Section 6. LED Indicators

Comm

Communication LED – Amber

- LED on when first powering up
- LED flashes number of communicating components in the system.
- (ex. communicating control with relay panel will equal two flashes)

HVAC System

HVAC System LEDs – Green

- A Green LED will illuminate when the relay is energized.

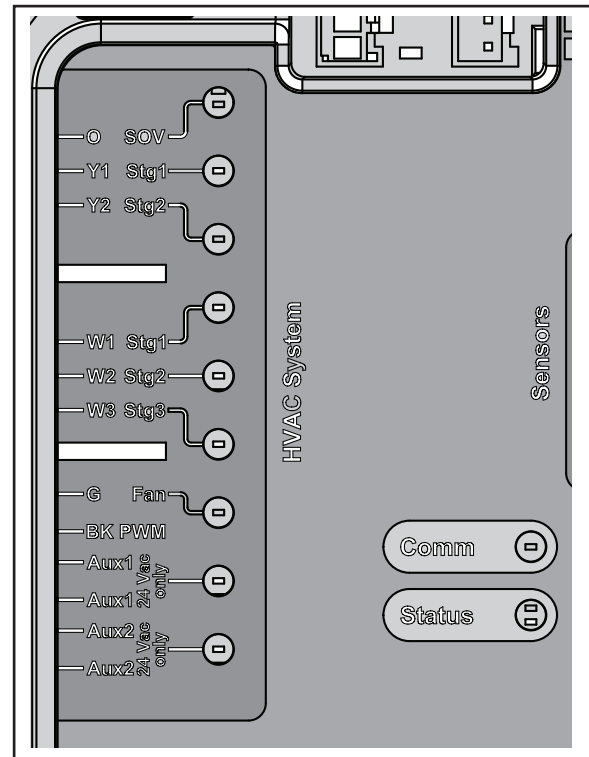

Section 7. Relay Panel Configuration

7.1 Relay Panel pre-configuration checklist

- All Link system components have CAN bus harness connectors. Ensure all parts of the system are connected and powered.
- Ensure the Relay Panel is properly wired and powered.
- Relay Panel configuration can be done from the Diagnostic Mobile App or from the Link system thermostat. ComfortSite or ASDealerNet credentials are required to configure via the App.
- The Diagnostic Mobile App can be downloaded and installed on your mobile device scanning the below QR codes:

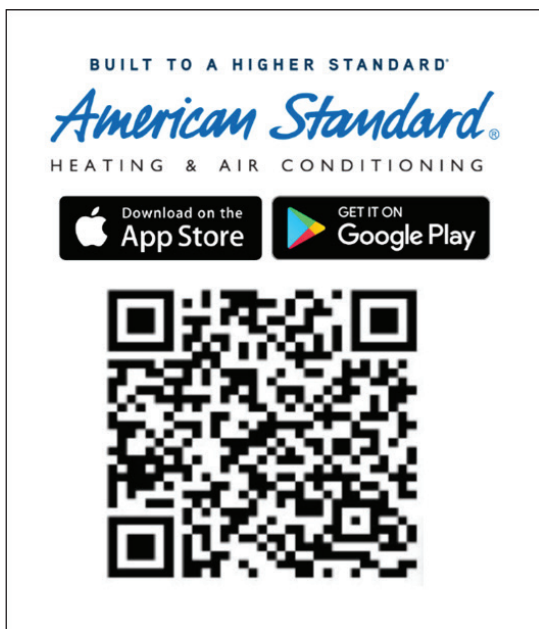

7.2 Connecting to the Link System with the Mobile Diagnostic App

- ComfortSite or ASDealerNet credential are required to connect to a Link system via the Diagnostic Mobile App.
- Connect to the Link system and verify the Relay Panel is displayed in the Equipment Summary.

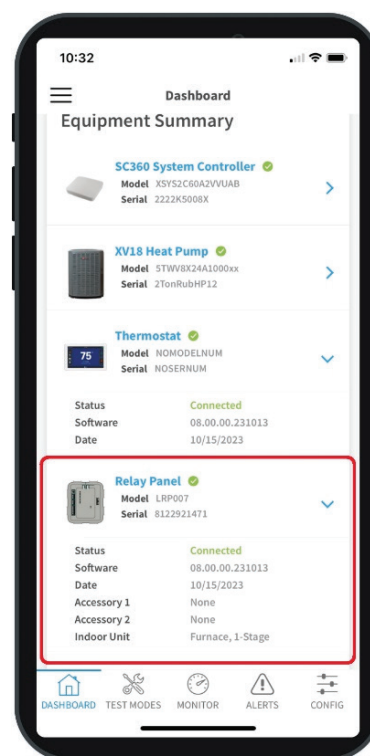

7.3 Relay Panel Configuration

- Relay Panel configuration can be accomplished using the Link UX360 Thermostat or via the Mobile Diagnostic App.
- From the Link UX360 Thermostat**, enter Configuration from the Technician Access menu and follow the onscreen guide to setup and configure all equipment associated with the Relay Panel.

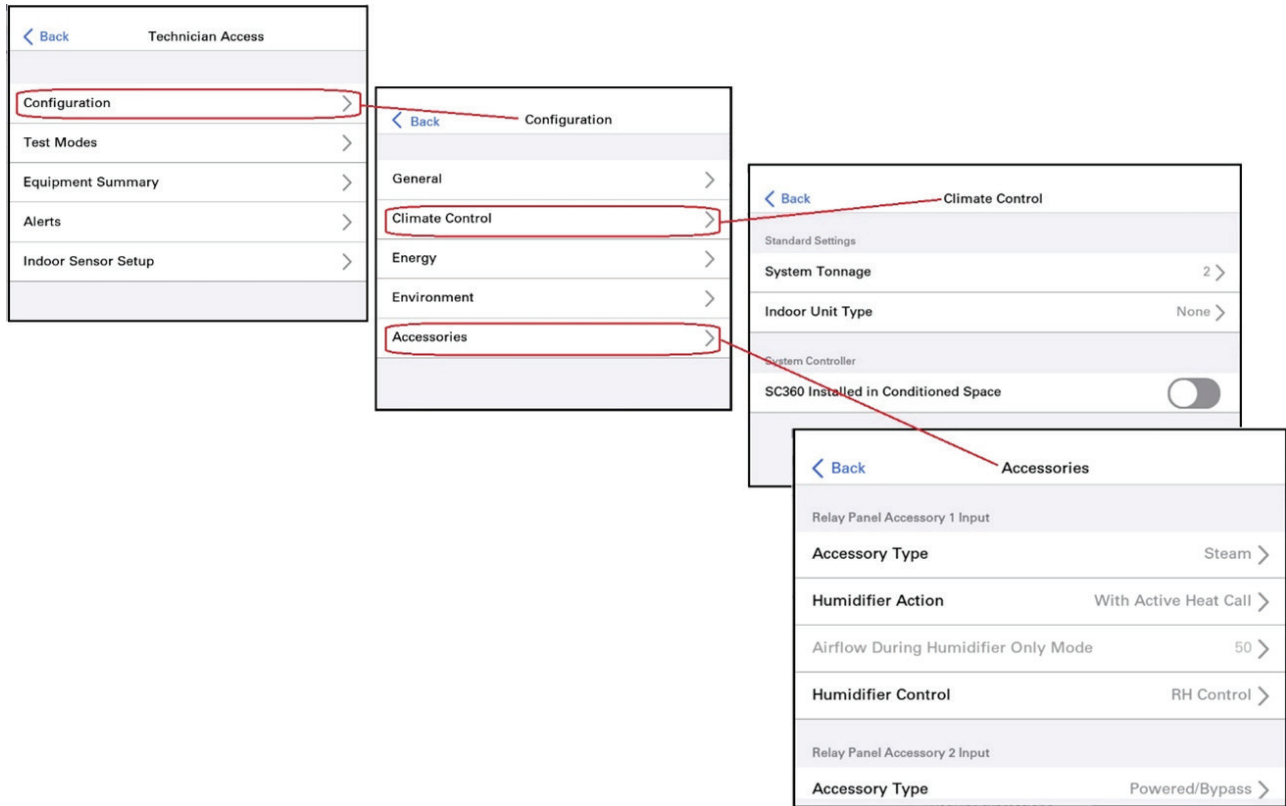

- Using the Diagnostic Mobile App**, enter the configuration section and using the “Setup Assistant”, follow the on-screen instructions to setup and configure all equipment associated with the Relay Panel.

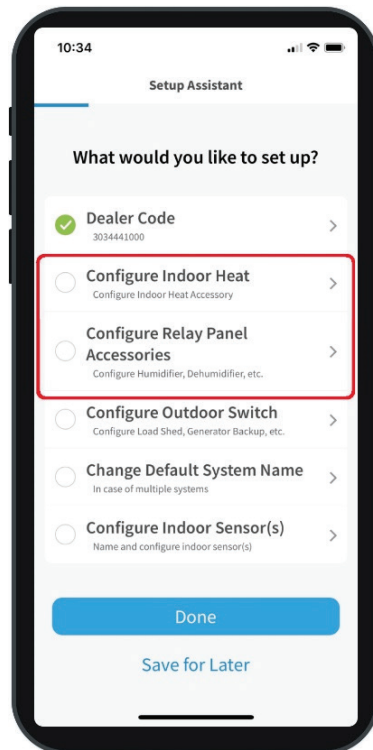

Section 8. Troubleshooting

8.1 Relay Panel LED Light Descriptions

The table below lists the meaning of the LED light indicators.

Condition	COM LED (AMBER)	Status LED's (GREEN)
Idle/Off	Off	Off
Startup	On (Solid)	On (Solid)
Active Demand	N/A	Slow Blink
Communication Established (CAN)	Node Count	N/A
Communication Lost (CAN)	Fast Blink	N/A

8.2 Additional Low Voltage Wiring Support

For additional information and support for troubleshooting the low voltage wiring for the Link Relay Panel, follow the link by scanning the QR code below with your mobile device.



NOTES:

NOTES:

About Trane and American Standard Heating and Air Conditioning

Trane and American Standard create comfortable, energy efficient indoor environments for residential applications. For more information, please visit www.trane.com or www.americanstandardair.com

The manufacturer has a policy of continuous data improvement and it reserves the right to change design and specifications without notice. We are committed to using environmentally conscious print practices.

18-HD101D1-1A-EN 11 Jan 2024

Supersedes (New)

© 2024