

# Submittal

## Single Packaged Gas Heating / Electric Cooling

4YCC4030E1070A

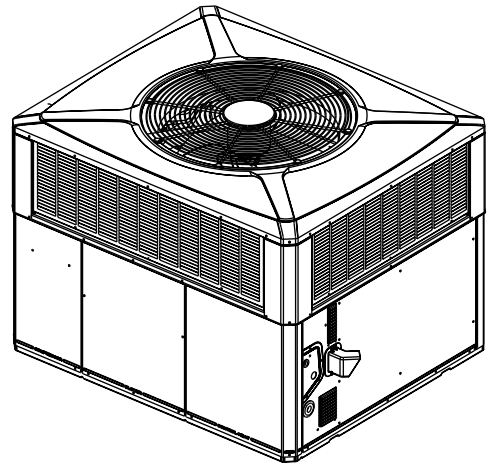

*Note: "Graphics in this document are for representation only. Actual model may differ in appearance."*

# Product Specifications

MODEL	4YCC4030E1070A
RATED Volts/PH/Hz	208-230/1/60
Performance Cooling BTUH <sup>(a)</sup>	28000
Indoor Airflow (CFM)	880
Power Input (KW)	2.21
EER2/SEER2 (BTU/Watt-Hr.)	11.00 / 13.40
Sound Power Rating [dB(A)] <sup>(b)</sup>	70.0
<b>PERFORMANCE HEATING<sup>(c)</sup></b>	
Input BTUH-1st Stage (Natural Gas) <sup>(d)</sup>	70000
AFUE	81
Temp. Rise — Min/Max (°F)	30 / 60
Orifice Qty/Drill Sz. (Natural Gas)	2 / #33
<b>POWER CONN. — V/Ph/Hz</b>	
Min. Brch. Cir. Ampacity <sup>(e)</sup>	20.8
Fuse Size — Max. (amps)	30
Fuse Size — Recmd. (amps)	30
<b>COMPRESSOR</b>	
	SCROLL
VOLTS/PH/HZ	208-230/1/60
R.L. Amps — L.R. Amps	12.8 / 67.8
<b>OUTDOOR COIL — TYPE</b>	
	SPINE-FIN
Rows/F.P.I	2 / 24
Face Area (sq. ft.)	13.32
Tube Size (in.)	3/8
<b>INDOOR COIL — TYPE</b>	
	MCHE
Rows/F.P.I	2 / 16
Face Area (sq. ft.)	2.7
Tube Size Width (in.)	0.81
Refrigeration Control	EXPANSION VALVE
Drain Conn. Size (in.)	3/4 FEMALE NPT
<b>OUTDOOR FAN — TYPE</b>	
	SWEPT
DIA. (IN.)	23.4
DRIVE/NO. SPEEDS	DIRECT / 1
CFM @ 0.0 in. w.g. <sup>(f)</sup>	2800
Motor — HP/R.P.M	1/6/ 825
Volts/Ph/Hz	208-230/1/60
F.L. Amps/L.R Amps	0.85 / 1.65

MODEL	4YCC4030E1070A
<b>INDOOR FAN — TYPE</b>	
	CONSTANT TORQUE ECM
Dia. x Width (in.)	10.62 X 10.62
Drive/No. Speeds	DIRECT / 4
CFM @ 0.0 in. w.g. <sup>(g)</sup>	SEE FAN PERF TABLE
Motor — HP/R.P.M.	1/2 / 1050
Volts/Ph/Hz	208-230/1/60
F.L. Amps	4.1
<b>COMBUSTION FAN — TYPE</b>	
	CENTRIFUGAL
Drive/No. Speeds	DIRECT / 1
Motor — HP/R.P.M.	1/34 / 3290
Volts/Ph/Hz	230/1/60
FLA	0.20
<b>FILTER / FURNISHED</b>	
Type Recommended	THROWAWAY
Recmd. Face Area (sq. ft) <sup>(h)</sup>	4.0
<b>REFRIGERANT</b>	
	R-410A
Charge (lbs.)	7.38
<b>CHARGING SPECIFICATIONS</b>	
Subcooling	8°
<b>GAS PIPE SIZE (in.)</b>	
	1/2
<b>DIMENSIONS</b>	
	H X D X W
Crated (in.)	48 X 45 X 52
<b>WEIGHT</b>	
Shipping (lbs.) / Net (lbs.)	451 / 377

<sup>(a)</sup> Rated in accordance with AHRI Standard 210/240. AHRI standard rating conditions are: 80 D.B.67 W.B. entering air to indoor coil. 95 D. B. entering air to outdoor coil.

<sup>(b)</sup> Sound Power values are not adjusted for AHRI 270-95 tonal corrections.

<sup>(c)</sup> Ratings shown are for elevations up to 2000 ft. For higher elevations reduce ratings at a rate of 4% per 1000 ft. elevation.

<sup>(d)</sup> Convertible to LPG.

<sup>(e)</sup> This value is approximate. For more precise value, see Unit Nameplate.

<sup>(f)</sup> Standard Air — Dry Coil — Outdoor.

<sup>(g)</sup> Based on U.S. Government Standard Tests.

<sup>(h)</sup> Filters must be installed in return air stream. Square footages listed are based on 300 f.p.m. face velocity. If permanent filters are used size per manufacturer's recommendation with a clean resistance of 0.05" W.C.

# Outline Drawings

Figure 1. 2 - 5 Ton Models

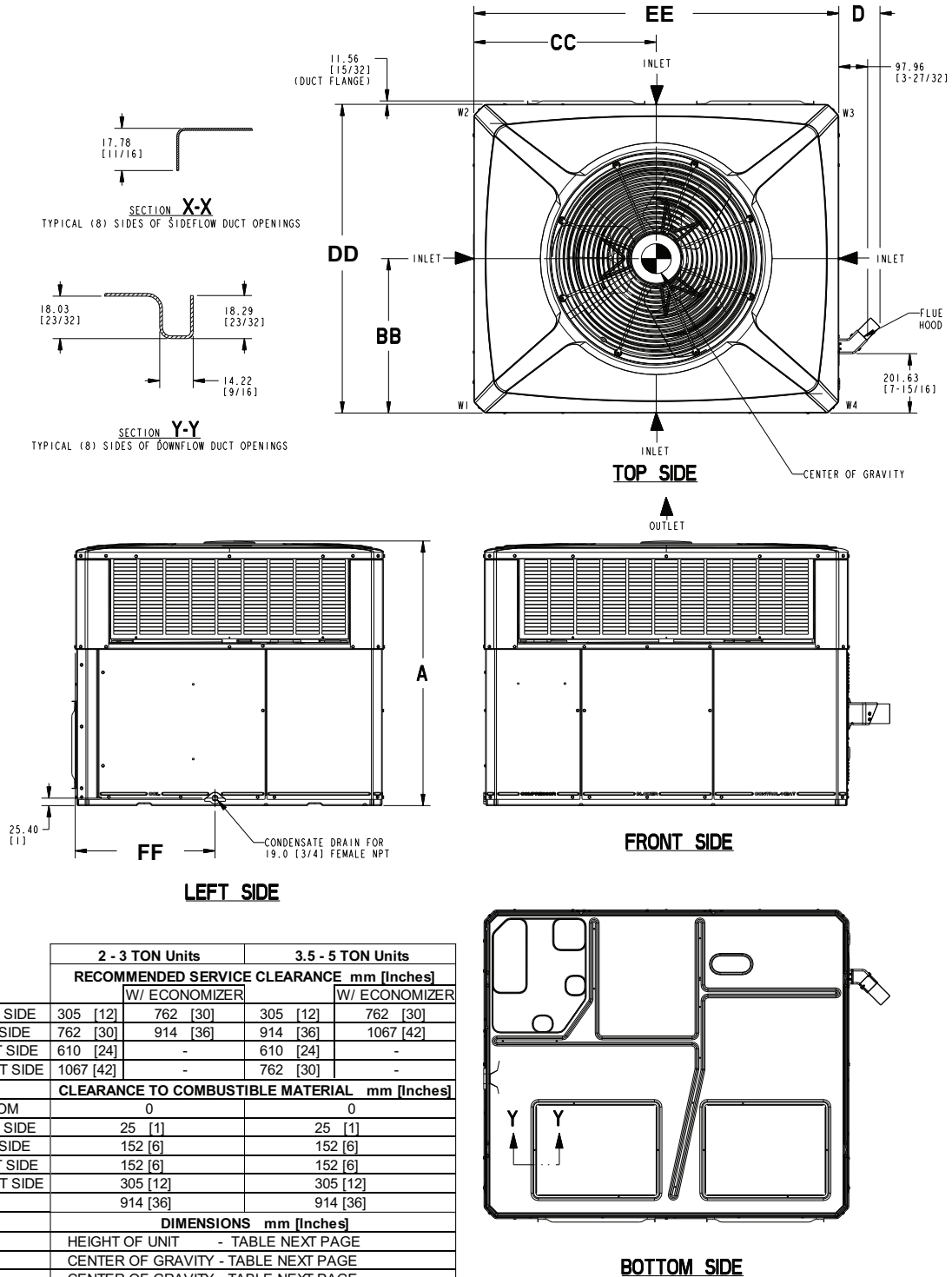

Note: The view labeled "Bottom side" represents the base as viewed looking up from underneath the unit.

Figure 2. 2 - 5 Ton Models

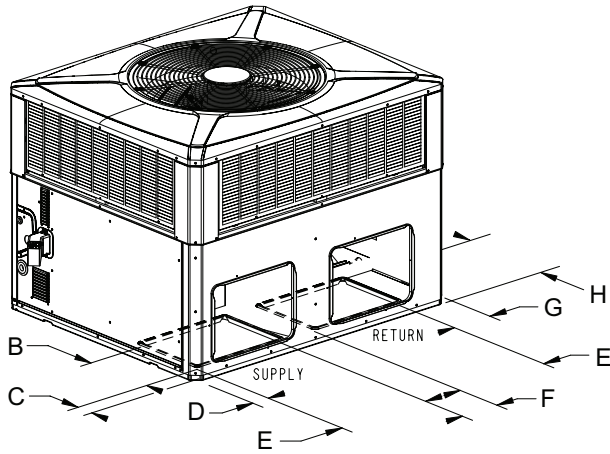

**BOTTOM DUCT OPENINGS**

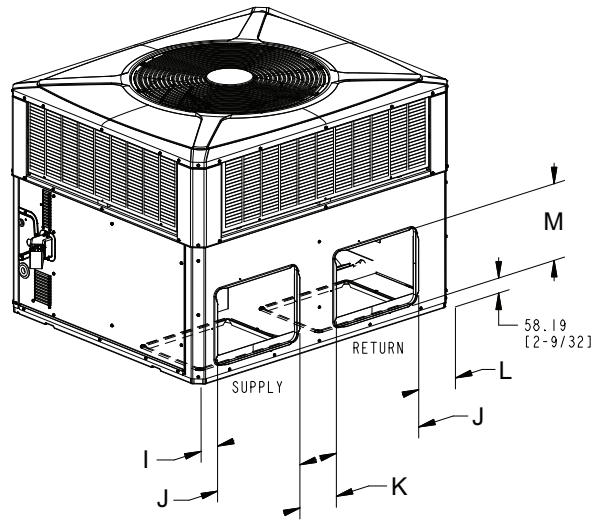

**BACK DUCT OPENINGS**

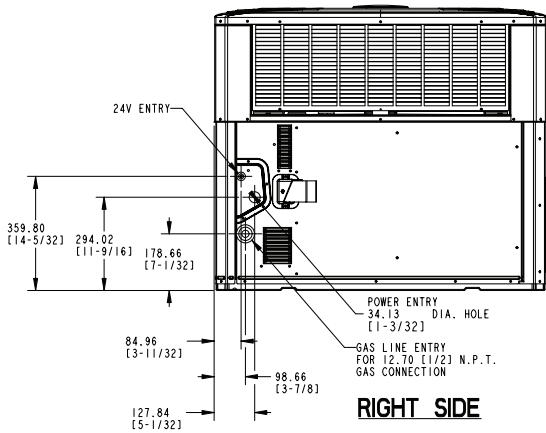

**RIGHT SIDE**

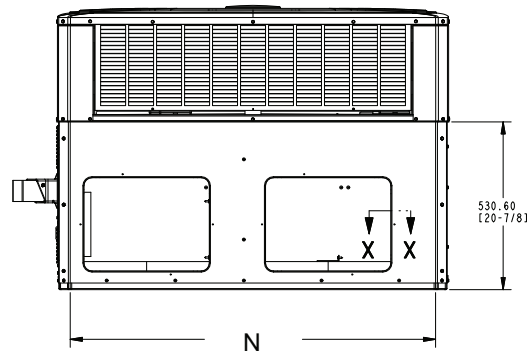

**BACK SIDE**

PHYSICAL DIMENSIONS mm[in]														
HEIGHT-A mm[inch]	B	C	D	E	F	G	H	I	J	K	L	M	N	
4YCC4024	898.53 [35-3/8]	304.80	75.41	75.41	406.40	167.89	173.46	304.80	79.50	398.22	176.07	177.55	296.62	1155.45
4YCC4030	949.33 [37-3/8]	[12]	[2.93]	[2.93]	[16]	[6.61]	[6-27/32]	[12]	[3.13]	[15.68]	[6.93]	[6.99]	[11.68]	[45.49]
4YCC4036														
4YCC4042	898.53 [35-3/8]	457.20	75.41	75.41	381.00	244.09	318.75	381.00	79.50	449.02	176.07	322.84	372.82	1402.34
4YCC4048		[18]	[2.97]	[2.97]	[15]	[9.61]	[12.55]	[15]	[3.13]	[17.68]	[6.93]	[12.71]	[14.68]	[55.21]
4YCC4060	1000.13 [35-3/8]													

	Corner Weights KG/LBS				SHIPPING WEIGHT KG/LBS	UNIT WEIGHT KG/LBS	Center Of Gravity mm[inch]	
	W1	W2	W3	W4			BB	CC
4YCC4024* (060)	58 [129]	37 [81]	26 [58]	41 [90]	196 [432]	162 [358]	480 [19]	528 [21]
4YCC4030* (070)	61 [135]	39 [85]	28 [61]	43 [95]	205 [451]	171 [377]	407 [16]	594 [23]
4YCC4036* (070)	61 [134]	39 [84]	28 [60]	43 [95]	205 [438]	171 [374]	407 [16]	594 [28]
4YCC4036* (090)	61 [136]	39 [86]	28 [61]	43 [96]	205 [453]	171 [379]	407 [16]	594 [28]
4YCC4042* (060)	71 [157]	47 [103]	35 [76]	53 [117]	252 [555]	202 [202]	470 [19]	731 [29]
4YCC4042* (090)	72 [158]	47 [104]	35 [78]	54 [118]	255 [561]	207 [202]	470 [19]	731 [29]
4YCC4048* (070)	71 [157]	45 [98]	33 [73]	54 [119]	250 [552]	202 [448]	433 [17]	743 [29]
4YCC4048* (090)	72 [159]	45 [99]	34 [75]	55 [120]	253 [557]	205 [453]	433 [17]	743 [29]
4YCC4060* (090)	77 [170]	46 [101]	35 [76]	58 [128]	263 [580]	216 [476]	433 [17]	743 [29]
4YCC4060* (115)	78 [172]	46 [102]	35 [77]	59 [130]	266 [586]	219 [482]	414 [16]	635 [25]

# Indoor Fan Performance

**Table 1. Airflow Tables – 2.5 Tons**

4YCC4030E1070		EXTERNAL STATIC PRESSURE (IN.WG) Horizontal Airflow [Down Airflow]										
Motor Speed		0.0	0.1	0.2	0.3	0.4	0.5	0.6	0.7	0.8	0.9	1
Constant Circulation	CFM	APPROXIMATELY 40-50% COOLING OR HEATING AIRFLOW										
	WATTS											
Cooling - Low	CFM	1051 (1041)	994 (984)	939 (930)	889 (880)	840 (831)	-	-	-	-	-	-
	WATTS	126 (126)	134 (135)	142 (143)	150 (150)	158 (158)	-	-	-	-	-	-
Cooling - Med	CFM	-	-	1108 (1097)	1070 (1059)	1027 (1017)	975 (965)	920 (911)	875 (866)	-	-	-
	WATTS	-	-	239 (240)	247 (248)	256 (258)	267 (269)	274 (276)	282 (284)	-	-	-
Cooling - High	CFM	-	-	-	-	1099 (1088)	1059 (1048)	1017 (1007)	968 (959)	-	-	-
	WATTS	-	-	-	-	259 (260)	268 (270)	278 (279)	289 (290)	-	-	-
Heating - Low	CFM	1148 (1136)	1103 (1091)	1061 (1050)	1022 (1012)	982 (972)	932 (922)	-	-	-	-	-
	WATTS	199 (197)	208 (205)	216 (214)	224 (222)	233 (230)	243 (241)	-	-	-	-	-
Heating - High	CFM	-	-	-	1158 (1147)	1122 (1111)	1084 (1073)	1039 (1028)	988 (978)	-	-	-
	WATTS	-	-	-	301 (298)	310 (307)	320 (317)	331 (328)	343 (339)	-	-	-

**Note:** Cooling airflow must not exceed 1125 CFM due to condensate blowoff.

To set indoor motor for the desired speed options, connect the motor leads in the taps as shown below:

**Table 2. Motor Wiring: 4YCC4024 - 42, 4YCC4060**

MOTOR WIRING	MOTOR TAP				
MODE/SPEED	1	2	3	4	5
CONSTANT CIRCULATION	G (GR)				
COOLING-LOW & HEATING-LOW	G (GR)	Y (YL)		W (PR)	
COOLING-LOW & HEATING-HIGH	G (GR)	Y (YL)			W (PR)
COOLING-MED & HEATING-LOW	G (GR)		Y (YL)	W (PR)	
COOLING-MED & HEATING-HIGH	G (GR)		Y (YL)		W (PR)
COOLING-HIGH & HEATING-LOW	G (GR)			W (PR)	Y (YL)
COOLING-HIGH & HEATING-HIGH	G (GR)			Y (YL)	W (PR)

G signal (GR - green wire), Y signal (YL - yellow wire), W signal (PR - purple wire)

# Full Perimeter Roof Mounting Curb

Figure 3. 2.0 – 3.0 Ton Models

## BAYCURB050A Full Perimeter Roof Mounting Curb

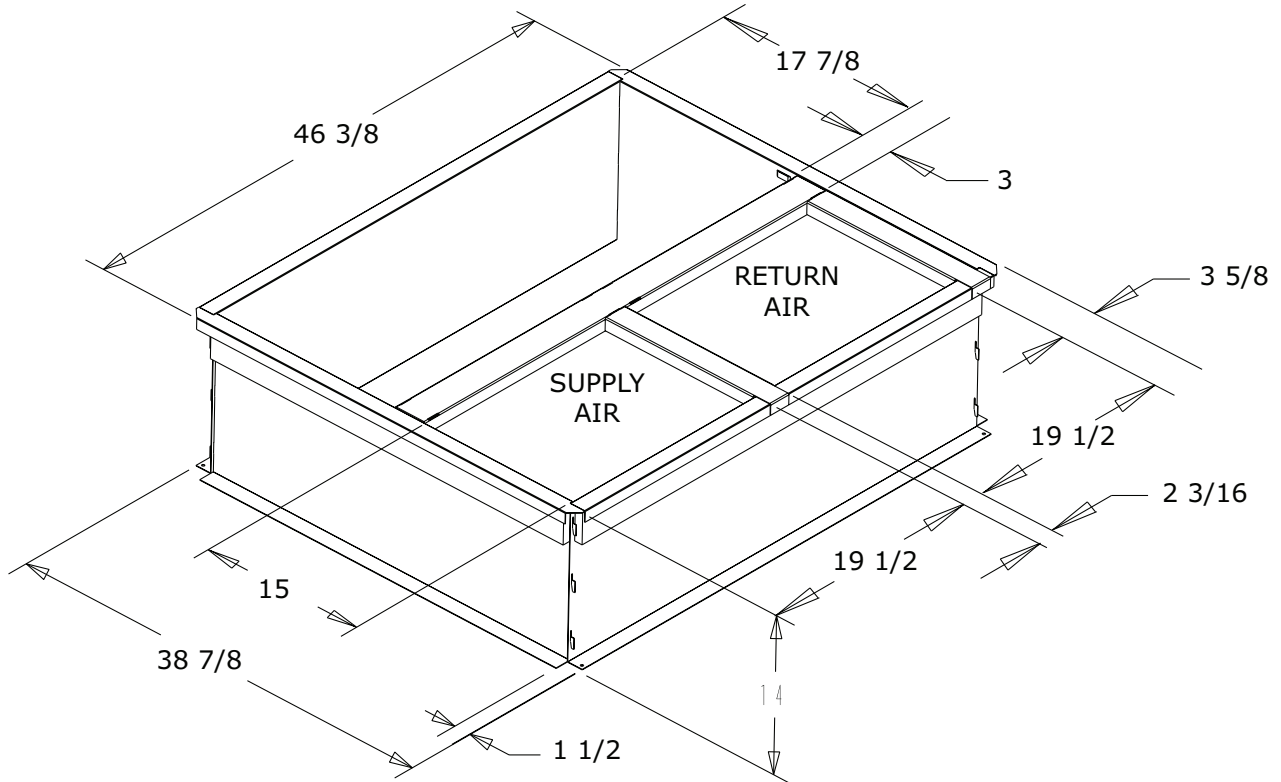

The drawings on this page are prepared by the manufacturer in order to provide detail regarding job layout only. These drawings are not intended to be used as a basis to construct, build or modify the items depicted in the drawings. The manufacturer is not responsible for the unauthorized use of these drawings and expressly disclaims any liability for damages resulting from such unauthorized use.

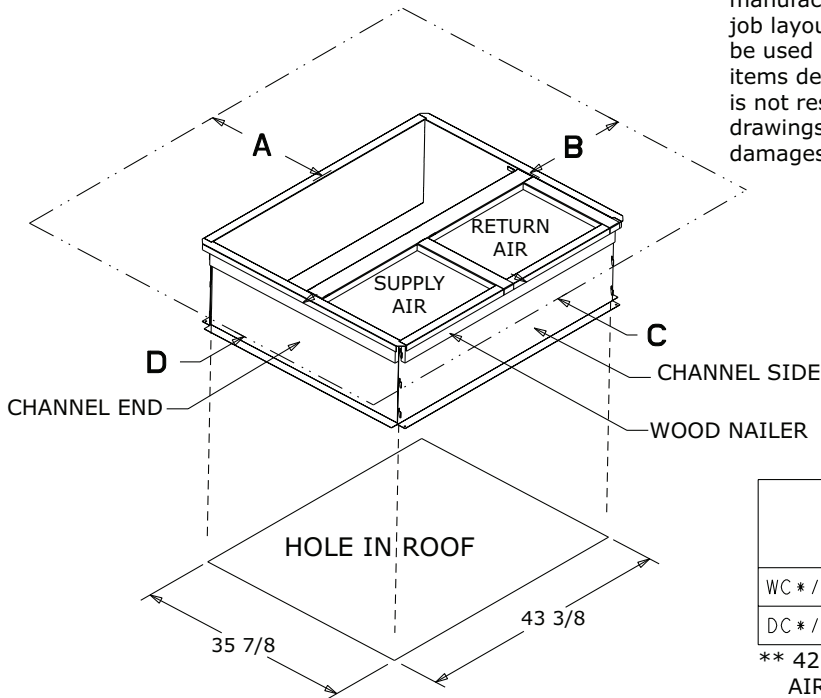

	SERVICE CLEARANCE DIMENSIONS			
	A	B	C	D
WC*/TC*	42.00	36.00	12.00**	24.00
DC*/YC*	42.00	36.00	12.00**	36.00

\*\* 42.00 WITH ECONOMIZER WITH 25% FRESH AIR ACCESSORY

# Optional Equipment – Filter Rack

**Figure 4. BAYFLTR101 Filter Rack (2.0 – 3.0 Ton Models)  
BAYFLTR201 (3.5 – 5.0 Ton Models)  
(Mounts in Filter/Coil Section)**

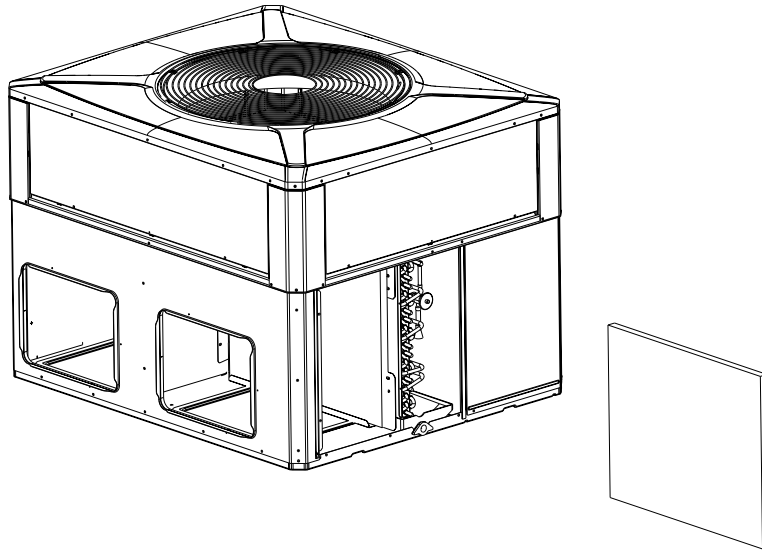

**Figure 5. BAYACCDOR1A Hinged Filter Access Door (2.0 – 3.0 Ton Models)  
BAYACCDOR2A (3.5 – 5.0 Ton Models)  
Replaces Filter/Coil Access Panel**

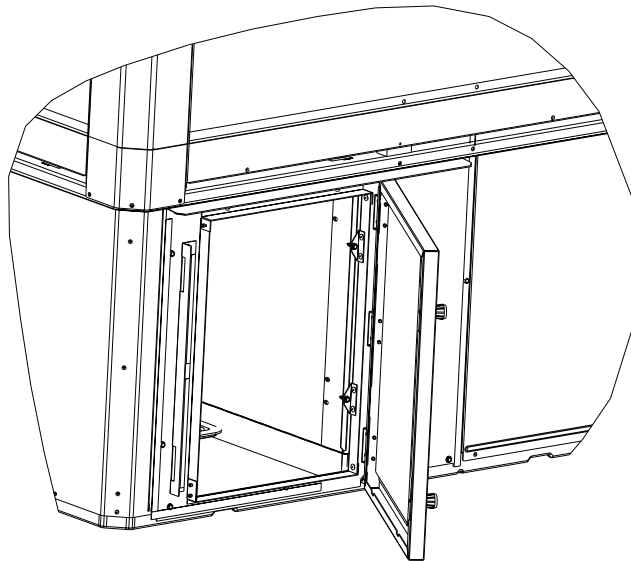

**Note:** The drawings on this page are prepared by the manufacturer in order to provide detail regarding job layout only. These drawings are not intended to be used as a basis to construct, build or modify the items depicted in the drawings. The manufacturer is not responsible for the unauthorized use of these drawings and expressly disclaims any liability for damages resulting from such unauthorized use.

# Optional Equipment – Economizer

**Table 3. BAYECON101,102A Down Discharge Economizer and Rain Hood (Mounts Over Horizontal Return Air Opening)**

	<b>Economizer</b>	<b>Unit Application Models</b>
	BAYECON101A	2.0 – 3.0 Ton Models
	BAYECON102A	3.5 – 5.0 Ton Models

**Table 4. BAYCON200, 201A Horizontal Economizer and Rain Hood**

<b>Economizer</b>	<b>Models</b>	<b>A</b>	<b>B</b>	<b>C</b>	<b>D</b>	<b>E</b>	<b>F</b>
BAYECON200A	2.0 – 3.0 Ton	22"	20"	16-7/8"	15-11/16"	11-11/16"	15"
BAYECON201A	3.5 – 5.0 Ton	26"	22-21/32"	19"	17-11/16"	14-11/16"	21-3/8"

**Note:** The drawings on this page are prepared by the manufacturer in order to provide detail regarding job layout only. These drawings are not intended to be used as a basis to construct, build or modify the items depicted in the drawings. The manufacturer is not responsible for the unauthorized use of these drawings and expressly disclaims any liability for damages resulting from such unauthorized use.



# Optional Equipment – Outside Air Damper

**Table 5. BAYOSAH001 and 002A Outside Air Damper  
(Replaces Filter/Coil Access Panel)**

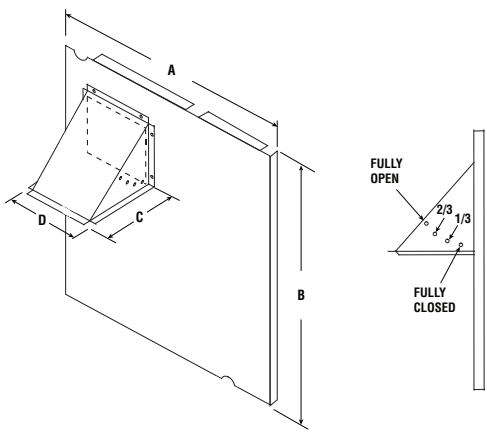
	Manual Fresh Air Model	Unit Application Models	A	B	C	D
	BAYOSAH001A	2.0 – 3.0 Ton	22-7/16"	20-11/16"	12-3/8"	9-3/16"
BAYOSAH002A	3.5 – 5.0 Ton	25-3/16"	20-11/16"	12-3/8"	9-3/16"	

**Table 6. BAYDMPR101 and 102A, 25% Motorized Outside Air Damper  
(Mounts Over Horizontal Return Air Opening)**

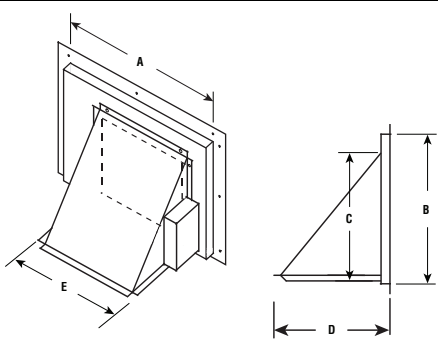
	Manual Fresh Air Model	Unit Application Models	A	B	C	D	E
	BAYDMPR101A	2.0 – 3.0 Ton	15-13/16"	11-13/16"	10-1/4"	11-1/2"	12-1/4"
BAYDMPR102A	3.5 – 5.0 Ton	18-3/16"	15-1/8"	10-1/4"	11-1/2"	12-1/4"	

**Note:** The drawings on this page are prepared by the manufacturer in order to provide detail regarding job layout only. These drawings are not intended to be used as a basis to construct, build or modify the items depicted in the drawings. The manufacturer is not responsible for the unauthorized use of these drawings and expressly disclaims any liability for damages resulting from such unauthorized use.

# Mechanical Specifications

## General

The units shall be horizontal airflow as shipped and convertible to downflow.

All units shall be factory assembled, piped, internally wired and fully charged with refrigerant. Units shall be certified to UL Standard 1995. Units shall be designed to operate at ambient temperatures as high as 115°F. Cooling performance shall be rated in accordance with AHRI standards. The YC heating/cooling unit design is certified to ANSI 221.47/CSA 2.3, specifically for outdoor applications using natural gas or propane. All units shall be designed for outdoor rooftop or ground level installation.

## Unit Casing

All components shall be mounted in a weather-resistant steel cabinet with an enamel finish. Access panels shall be provided for unit controls and indoor coil and fans. Indoor air section compartment shall be completely insulated with fireproof, permanent, odorless fiber material. Knockouts shall be provided for utility and control connections. Drain connections shall be provided to accommodate indoor water runoff.

## Compressor

The compressor shall be hermetically sealed, high efficiency scroll compressors. Internal overcurrent and over temperature protection, internal pressure relief shall be standard. Other features include centrifugal oil pump, low vibration and noise.

## Refrigeration System

All units shall have refrigerant control. Service pressure tap ports and a refrigerant line filter shall be standard.

**Evaporator Coil (2—4 Ton Models)** All aluminum micro channel, extruded tubes, mechanically bonded to aluminum fins, and factory pressure and leak tested at 480 — 650 psig. All units have TXV to control refrigerant flow.

## Condenser Coil

The Spine Fin™ condenser coil shall be continuously wrapped, corrosion resistant all aluminum with minimum brazed joints. This coil is 3/8" OD seamless aluminum tubing glued to a continuous aluminum fin. Coils are lab tested to withstand 2,000 pounds of pressure per square inch. The outdoor coil provides low airflow resistance and efficient heat transfer. The coil is protected on all four sides by louvered panels.

## Indoor Air Fan

Constant Torque, forward-curved, centrifugal wheel in a Composite Vortica® Blower housing. Motor shall have thermal overload protection and permanently lubricated motor bearings. Motor/blower assembly isolated from unit with rubber mounts.

## Outdoor Fan

One direct-drive, statically and dynamically balanced propeller fan shall be used in a draw-through vertical discharge configuration. Permanently lubricated weather proof motor shall have built-in thermal overload protection.

## System Controls

System controls include condenser fan, evaporator fan and compressor contactors.

## Accessories Roof Curb

The roof curb shall be designed to mate with the unit and provide support and complete weathertight installation when properly installed. Adhesive back polyurethane sealing strips shall be provided to ensure an airtight seal between supply and return openings of the curb and unit. The roof curb design allows field fabricated ductwork to be connected directly to the curb. Curb ships knocked down for field assembly, and includes factory installed wood nailer strips.

## Heating System

### Gas-Fired Heating Section

Models shall provide completely assembled, wired and piped gas fired heating systems within unit. Design certified by UL, specifically for outdoor application. Threaded gas connection on the unit.

### Electric Ignition System

Main burner is lit each time thermostat calls for heat. Flame sensor proves flame and keeps the main burner on. Should a loss of flame occur, the main valve closes and the spark recurs within 0.8 seconds. When thermostat is satisfied, main burner is extinguished.

### Forced Combustion Blower

Insures flame stability under varying wind conditions. Gives higher combustion efficiency and location flexibility.

### Heat Exchanger

Stainless steel tubes. Free floating design.

### Burners

Stainless steel. Multi-port inshot.

### **Single Source Power Entry**

This accessory when used with electric heat accessory shall allow single source power connection to unit and heater combination. Single source power entry kits shall have specific matching heater(s). Kit shall include high voltage terminal blocks, fuse blocks and fuses, cut-to-length interconnecting wiring, and junction box (if required) to provide power sources with fuse protection as required for both the unit and accessory heater. Kit components shall install within the heater cabinet in the heater access section. Single source branch power circuit shall be protected and wired in accordance with local codes.

### **Fully Modulating Economizer**

This accessory shall be field installed and be composed of the following items: 0–100 % fresh air damper, damper drive motor, fixed dry bulb enthalpy control, and low voltage pigtails for electrical connections. Solid state enthalpy or differential enthalpy control is optional. Economizer operations shall be controlled by the preset position of the enthalpy control. A barometric relief damper shall be standard with the economizer and provide a pressure operated damper

that shall be gravity closing and prohibit entrance of outside air on equipment "off" cycle. Economizer requires BAYRLAY004A relay kit to interface the economizer to the heat pump.

### **Manual Outside Air Dampers**

Rain hood and screen shall be field installed. Suitable for up to 25% outside air.

### **Start Kit**

Extra compressor starting capacity for single phase equipment.

### **Control Options**

#### **Standard Indoor Thermostats**

Two stage heating/cooling or one stage heating/cooling thermostats shall be available in either manual or automatic changeover.

#### **Programmable Electronic Night Setting Thermostat**

Programmable electronic thermostat shall provide heating setback and cooling setup with 7–day programming capability. 1H/1C or 2H/2C models available.

## About Trane and American Standard Heating and Air Conditioning

Trane and American Standard create comfortable, energy efficient indoor environments for residential applications. For more information, please visit [www.trane.com](http://www.trane.com) or [www.americanstandardair.com](http://www.americanstandardair.com).



The AHRI Certified mark indicates company participation in the AHRI Certification program. For verification of individual certified products, go to [ahridirectory.org](http://ahridirectory.org).

The manufacturer has a policy of continuous data improvement and it reserves the right to change design and specifications without notice. We are committed to using environmentally conscious print practices.