

Installation Instructions

0-50% Manual Outside Air Damper

Model Number:	Used With:
BAYDMPR053*	T/Y/WSC060EDK, T/Y/WSC060ED, T/YHC036E1,3,4, T/YHC037E3,4, T/Y/WSC060ED, T/YSC036-060G3,4,W, D/WHC036H, WSC036-048H
BAYDMPR056*	T/Y/WS072-120EDK, T/Y/WSJ072-120ED, T/YSC072-120H3,4,W, T/YSC120FK, WSC072-120E3,4,W, T/YHC047-067E3,4, T/YHC072-102F3,4, T/YHC120E3,4, T/YHC120F, WSC060-120H, D/WHC048-120H
FIADMPR002*	T/YS*072-150

SAFETY WARNING
 Only qualified personnel should install and service the equipment. The installation, starting up, and servicing of heating, ventilating, and air-conditioning equipment can be hazardous and requires specific knowledge and training. Improperly installed, adjusted or altered equipment by an unqualified person could result in death or serious injury. When working on the equipment, observe all precautions in the literature and on the tags, stickers, and labels that are attached to the equipment.

August 2022

ACC-SVN01Q-EN

©2022

1 Warnings, Cautions, and Notices

Read this manual thoroughly before operating or servicing this unit. Safety advisories appear throughout this manual as required. Your personal safety and the proper operation of this machine depend upon the strict observance of these precautions.

The three types of advisories are defined as follows:

- WARNING** Indicates a potentially hazardous situation which, if not avoided, could result in death or serious injury.
- CAUTION** Indicates a potentially hazardous situation which, if not avoided, could result in minor or moderate injury. It could also be used to alert against unsafe practices.
- NOTICE** Indicates a situation that could result in equipment or property-damage only accidents.

Important Environmental Concerns

Scientific research has shown that certain man-made chemicals can affect the earth's naturally occurring stratospheric ozone layer when released to the atmosphere. In particular, several of the identified chemicals that may affect the ozone layer are refrigerants that contain Chlorine, Fluorine and Carbon (CFCs) and those containing Hydrogen, Chlorine, Fluorine and Carbon (HCFCs). Not all refrigerants containing these compounds have the same potential impact to the environment. Trane advocates the responsible handling of all refrigerants-including industry replacements for CFCs such as HCFCs and HFCs.

Important Responsible Refrigerant Practices

Trane believes that responsible refrigerant practices are important to the environment, our customers, and the air conditioning industry. All technicians who handle refrigerants must be certified according to local rules. For the USA, the Federal Clean Air Act (Section 608) sets forth the requirements for handling, reclaiming, recovering and recycling of certain refrigerants and the equipment that is used in these service procedures. In addition, some states or municipalities may have additional requirements that must also be adhered to for responsible management of refrigerants. Know the applicable laws and follow them.

2 WARNING

Proper Field Wiring and Grounding Required!
 Failure to follow code could result in death or serious injury. All field wiring MUST be performed by qualified personnel. Improperly installed and grounded field wiring poses FIRE and ELECTROCUTION hazards. To avoid these hazards, you MUST follow requirements for field wiring installation and grounding as described in NEC and your local/state/national electrical codes.

WARNING

Personal Protective Equipment (PPE) Required!
 Failure to wear proper PPE for the job being undertaken could result in death or serious injury. Technicians, in order to protect themselves from potential electrical, mechanical, and chemical hazards, MUST follow precautions in this manual and on the tags, stickers, and labels, as well as the instructions below:

- Before installing/servicing this unit, technicians MUST put on all PPE required for the work being undertaken (Examples; cut resistant gloves/sleeves, butyl gloves, safety glasses, hard hat/bump cap, fall protection, electrical PPE and arc flash clothing). ALWAYS refer to appropriate Safety Data Sheets (SDS) and OSHA guidelines for proper PPE.
- When working with or around hazardous chemicals, ALWAYS refer to the appropriate SDS and OSHA/GHS (Global Harmonized System of Classification and Labeling of Chemicals) guidelines for information on allowable personal exposure levels, proper respiratory protection and handling instructions.
- If there is a risk of energized electrical contact, arc, or flash, technicians MUST put on all PPE in accordance with OSHA, NFPA 70E, or other country-specific requirements for arc flash protection, PRIOR to servicing the unit. NEVER PERFORM ANY SWITCHING, DISCONNECTING, OR VOLTAGE TESTING WITHOUT PROPER ELECTRICAL PPE AND ARC FLASH CLOTHING. ENSURE ELECTRICAL METERS AND EQUIPMENT ARE PROPERLY RATED FOR INTENDED VOLTAGE.

3 WARNING

Follow EHS Policies!
 Failure to follow instructions below could result in death or serious injury.

- All Trane personnel must follow the company's Environmental, Health and Safety (EHS) policies when performing work such as hot work, electrical, fall protection, lockout/tagout, refrigerant handling, etc. Where local regulations are more stringent than these policies, those regulations supersede these policies.
- Non-Trane personnel should always follow local regulations.

Copyright

This document and the information in it are the property of Trane, and may not be used or reproduced in whole or in part without written permission. Trane reserves the right to revise this publication at any time, and to make changes to its content without obligation to notify any person of such revision or change.

Trademark

All trademarks referenced in this document are the trademarks of their respective owners.

General Information

Manual outside air damper supplied in return air section of unit. To access, remove unit end panel, remove and discard shipping bracket, reinstall screw into unit base, and follow installation instructions.

4

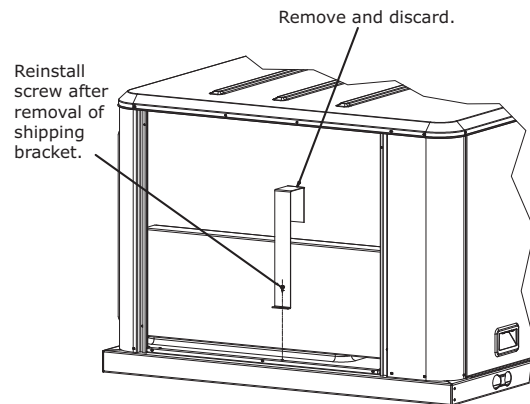

This instruction covers field installation of BAYDMPR056* (Precedent™ C/D/E cabinet, digit 30 = C, D or E), and FIADMPR002* (Precedent™ B/C cabinet, digit 39 = B or C).

Remove the damper from crating and locate all parts shown as indicated.

Parts List

- One (1) RH Side Panel
- One (1) LH Side Panel
- One (1) Rear Panel
- One (1) Sliding Baffle
- One (1) Sealing Bracket
- One (1) Mist Eliminator
- Nine (9) Screws
- One (1) Gasket

5 Installation Procedure

WARNING
Hazardous Voltage!
 Failure to disconnect power before servicing could result in death or serious injury. Disconnect all electric power, including remote disconnects before servicing. Follow proper lockout/tagout procedures to ensure the power can not be inadvertently energized. Verify that no power is present with a voltmeter.

1. Remove end panel from unit as shown in Figure 1. To avoid scratching the end panel, flatten the damper shipping box, place the packing material on top, and lay the end panel paint side down.

Figure 1. End panel removal

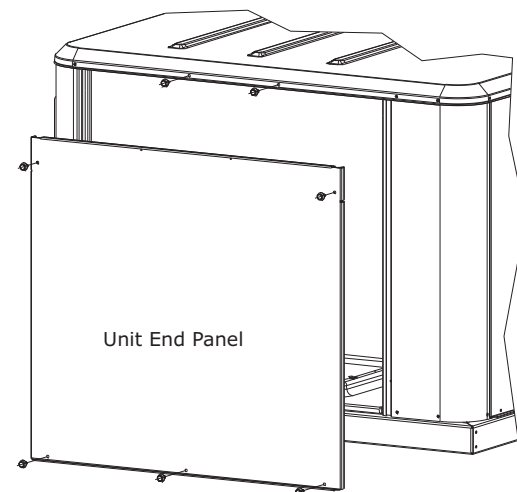

6

2. Select the damper position based on unit tonnage and desired airflow from Table 1. Position the sliding baffle on the rear panel by aligning the screw hole with the selected damper positioning dimple in the sliding baffle and secure as shown in Figure 2.

Example: The building return static pressure measures negative 0.1-inch for a YSC036 unit, and 400 CFM of fresh air is needed. Reference Table 1 to select position D and position the sliding baffle so the screws line up with the fourth dimple in the sliding baffle.

Figure 2. Sliding baffle/rear panel

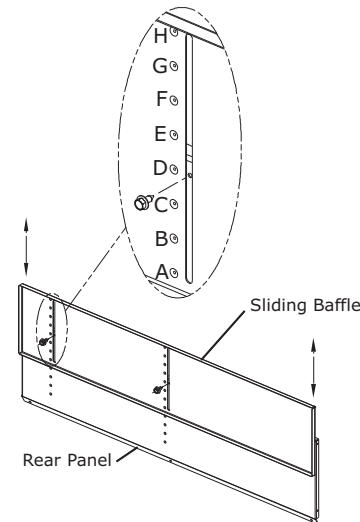

3. Position the RH side panel by aligning the three tabs with the slots on the unit end panel. See Figure 3.

Figure 3. RH side panel

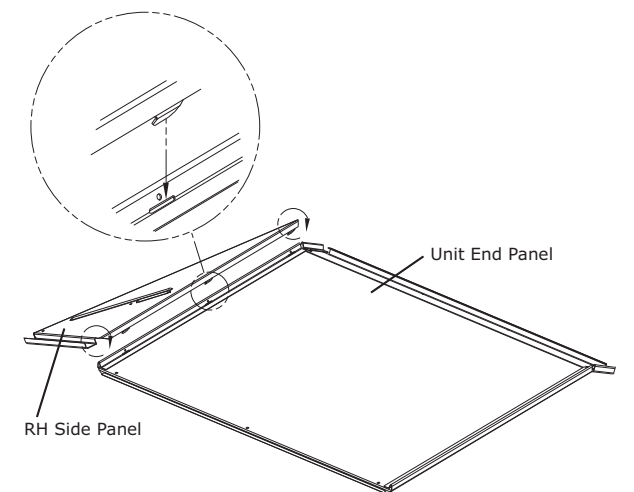

8

4. Position the rear panel/sliding baffle assembly and rotate the RH panel in place. Insert two screws. See [Figure 4](#).

Figure 4. Rear panel/sliding baffle

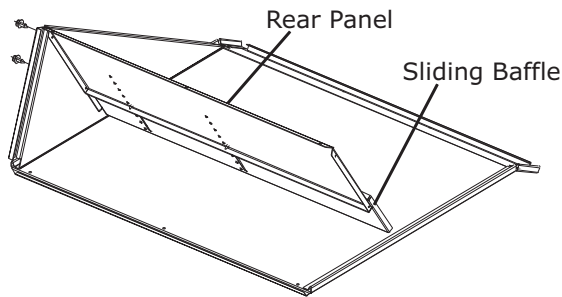

5. Position the LH panel by aligning the three tabs with the slots on the unit end panel in [Step 2](#). Rotate in place and insert two screws to connect the LH side panel to the rear panel. Attach the sealing bracket to the unit end panel using three screws. See [Figure 5](#).

Figure 5. LH side panel

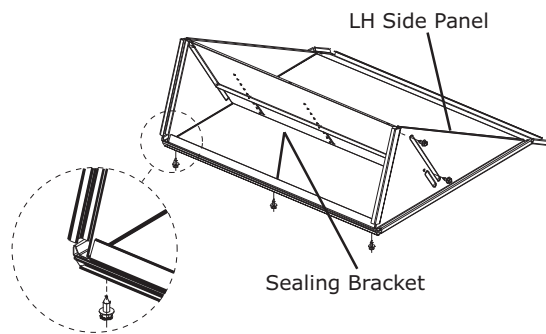

9

6. Apply gasket to flanges of side panels. Align the edge of the gasket with the outside edge of the side panel flanges. See [Figure 6](#).

Figure 6. Gasket

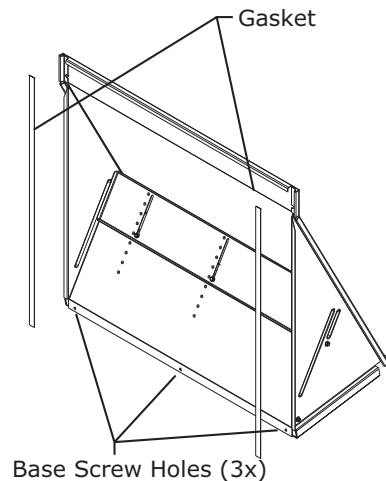

10

7. Install damper assembly onto the unit.
Insert top center screws first, bottom screws into the unit base next, and remaining screws around the perimeter last.
8. Insert mist eliminator by sliding it in the filter channel located on the side panels.

Important: Arrows on the mist eliminator should point in the direction of airflow. See [Figure 7](#).

Figure 7. Mist eliminator

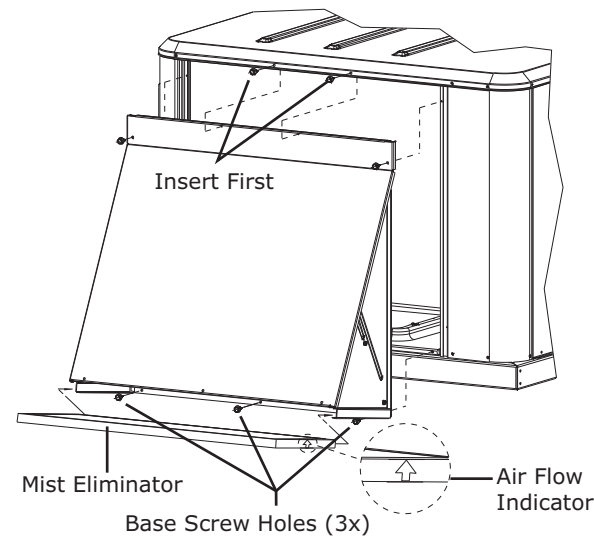

11

WARNING

Live Electrical Components!
Failure to follow all electrical safety precautions when exposed to live electrical components could result in death or serious injury.
When it is necessary to work with live electrical components, have a qualified licensed electrician or other individual who has been properly trained in handling live electrical components perform these tasks.

Important: Measure the full load amps of the supply fan motor. If the amperage exceeds the motor nameplate value, system CFM may be too high.

9. In order to lower the motor amperage to the nameplate value, adjust the fresh air damper or fan RPM.

Table 1. T/Y/WSC036, W/DHC036H

Damper Position	Return Static - Inch W.G.						
	-0.1	-0.2	-0.3	-0.4	-0.5	-0.6	-0.7
A	80	100	120	140	170	200	240
B	200	240	300	360	420	490	570
C	310	410	510	610	***	***	***
D	410	540	***	***	***	***	***
E	520	***	***	***	***	***	***

12

Table 2. T/Y/WSC048

Damper Position	Return Static - Inch W.G.						
	-0.10	-0.20	-0.30	-0.40	-0.50	-0.60	-0.70
A	80	100	120	140	170	200	240
B	200	240	300	360	420	490	570
C	310	410	510	610	710	800	890
D	410	540	700	860	***	***	***
E	520	700	***	***	***	***	***

Table 3. T/YSC060, WSC060ED, T/YHC036E, T/YHC037E

Damper Position	Return Static - Inch W.G.						
	-0.10	-0.20	-0.30	-0.40	-0.50	-0.60	-0.70
A	80	100	120	140	170	200	240
B	200	240	300	360	420	490	570
C	310	410	510	610	710	800	890
D	410	540	700	860	***	***	***
E	520	700	***	***	***	***	***

13

Table 4. T/YS*072, WSC072, WSC060, W/DHC048-074H, T/YHC047E, T/YHC048E, T/YHC060E, T/YHC067E, T/YHC072

Damper Position	Return Static - Inch W.G.						
	-0.10	-0.20	-0.30	-0.40	-0.50	-0.60	-0.70
A	260	340	430	520	600	670	740
B	400	520	650	780	910	1040	1160
C	540	720	900	1080	1250	***	***
D	690	920	1150	***	***	***	***
E	860	1160	***	***	***	***	***
F	1060	***	***	***	***	***	***
G	1290	***	***	***	***	***	***
H	***	***	***	***	***	***	***

Table 5. T/YS*072-120, T/YHC090, T/YHC102, WSC090-102, D/WHC090-102, T/YHC074F, T/YHC092F

Damper Position	Return Static - Inch W.G.						
	-0.10	-0.20	-0.30	-0.40	-0.50	-0.60	-0.70
A	260	340	430	520	600	670	740
B	400	520	650	780	910	1040	1160
C	540	720	900	1080	1250	1420	1580
D	690	920	1150	1380	1580	1770	***
E	860	1160	1450	1700	***	***	***
F	1060	1400	1720	***	***	***	***
G	1290	1700	***	***	***	***	***
H	1530	***	***	***	***	***	***

14

Table 6. T/YS*150, WSC120, T/YHC120, D/WHC120

Damper Position	Return Static - Inch W.G.						
	-0.10	-0.20	-0.30	-0.40	-0.50	-0.60	-0.70
A	260	340	430	520	600	670	740
B	400	520	650	780	910	1040	1160
C	540	720	900	1080	1250	1420	1580
D	690	920	1150	1380	1580	1770	2000
E	860	1160	1450	1700	1950	2200	***
F	1060	1400	1720	2020	***	***	***
G	1290	1700	2100	***	***	***	***
H	1530	1970	***	***	***	***	***

Trane and American Standard create comfortable, energy efficient indoor environments for commercial and residential applications. For more information, please visit trane.com or americanstandardair.com.

Trane and American Standard have a policy of continuous product and product data improvement and reserve the right to change design and specifications without notice. We are committed to using environmentally conscious print practices.