

# Installation Instructions

## Economizer Packaged Rooftop Units

Model Number:	Used With:
BAYECON085*	Precedent™ B/F Cabinet with ReliaTel™ Controls- T/YSC036-060E*R, WSC060EDR, T/YHC036E*R, T/YHC037E*R, T/YZC036E, T/YSC036-060G*R, WSC036-048H, D/WHC036H
BAYECON086*	Precedent™ B/F Cabinet with Electromechanical Controls- T/YHC036E*R, T/YSC036-060E*R, T/YSC036-060G*R
BAYECON087*	Precedent™ C/D/E Cabinet with ReliaTel™ Controls- T/YHC047E-067E*R, T/YHC048-60E*R, T/YHC072-102F*R, T/YHC120E*R, T/YSC(072-120)F/H*R, WSC072-120E*R, T/YHC048-060F*R, WSC060-120H, D/WHC048-120H, T/YZC048-120
BAYECON088*	Precedent™ C/D/E Cabinet with Electromechanical Controls- T/YHC048E-120E*R, T/YSC(072-120)F/H*R, T/YHC(048-060)F*R, T/YHC092F*R, T/YHC074F(3/4)E

**SAFETY WARNING**  
 Only qualified personnel should install and service the equipment. The installation, starting up, and servicing of heating, ventilating, and air-conditioning equipment can be hazardous and requires specific knowledge and training. Improperly installed, adjusted or altered equipment by an unqualified person could result in death or serious injury. When working on the equipment, observe all precautions in the literature and on the tags, stickers, and labels that are attached to the equipment.

April 2020 ACC-SVN44P-EN © 2020

### 1 Warnings, Cautions, and Notices

Read this manual thoroughly before operating or servicing this unit. Safety advisories appear throughout this manual as required. Your personal safety and the proper operation of this machine depend upon the strict observance of these precautions.

The three types of advisories are defined as follows:

- WARNING** Indicates a potentially hazardous situation which, if not avoided, could result in death or serious injury.
- CAUTION** Indicates a potentially hazardous situation which, if not avoided, could result in minor or moderate injury. It could also be used to alert against unsafe practices.
- NOTICE** Indicates a situation that could result in equipment or property-damage only accidents.

#### Important Environmental Concerns

Scientific research has shown that certain man-made chemicals can affect the earth's naturally occurring stratospheric ozone layer when released to the atmosphere. In particular, several of the identified chemicals that may affect the ozone layer are refrigerants that contain Chlorine, Fluorine and Carbon (CFCs) and those containing Hydrogen, Chlorine, Fluorine and Carbon (HCFCs). Not all refrigerants containing these compounds have the same potential impact to the environment. Trane advocates the responsible handling of all refrigerants-including industry replacements for CFCs such as HCFCs and HFCs.

#### Important Responsible Refrigerant Practices

Trane believes that responsible refrigerant practices are important to the environment, our customers, and the air conditioning industry. All technicians who handle refrigerants must be certified according to local rules. For the USA, the Federal Clean Air Act (Section 608) sets forth the requirements for handling, reclaiming, recovering and recycling of certain refrigerants and the equipment that is used in these service procedures. In addition, some states or municipalities may have additional requirements that must also be adhered to for responsible management of refrigerants. Know the applicable laws and follow them.

### 2 Warnings

**WARNING**  
**Proper Field Wiring and Grounding Required!**  
 Failure to follow code could result in death or serious injury. All field wiring MUST be performed by qualified personnel. Improperly installed and grounded field wiring poses FIRE and ELECTROCUTION hazards. To avoid these hazards, you MUST follow requirements for field wiring installation and grounding as described in NEC and your local/state electrical codes.

**WARNING**  
**Personal Protective Equipment Required!**  
 Installing/servicing this unit could result in exposure to electrical, mechanical and chemical hazards. Before installing/servicing this unit, technicians MUST put on all Personal Protective Equipment (PPE) recommended for the work being undertaken. ALWAYS refer to appropriate SDS sheets and OSHA guidelines for proper PPE. When working with or around hazardous chemicals, ALWAYS refer to the appropriate SDS sheets and OSHA guidelines for information on allowable personal exposure levels, proper respiratory protection and handling recommendations. If there is a risk of arc or flash, technicians MUST put on all necessary Personal Protective Equipment (PPE) in accordance with NFPA70E for arc/flash protection PRIOR to servicing the unit. Failure to follow recommendations could result in death or serious injury.

**WARNING**  
**Follow EHS Policies!**  
 Failure to follow instructions below could result in death or serious injury.

- All Trane personnel must follow the company's Environmental, Health and Safety (EHS) policies when performing work such as hot work, electrical, fall protection, lockout/tagout, refrigerant handling, etc. Where local regulations are more stringent than these policies, those regulations supersede these policies.
- Non-Trane personnel should always follow local regulations.

### 3 Parts list

- 1 - Economizer Assembly
- 1 - Mist Eliminator
- 1 - Tie, Wire
- 10 - Screws
- 1 - Sensor, Thermistor (18, 19, 20)
- 1 - Grommet (24)
- 1 - Duct Blockoff Plate (15)
- 12 - Screws
- 1 - Bottom Blockoff (21)

#### Field Installed Assembly and Installation

This section covers installation of economizer units that were not installed in the rooftop unit at the factory.

#### Unpack Economizer

- See Figure 1.  
 Remove 1, 2, and 3.
- Remove the screws completely from 1 and 2. Retain them for reassembly.
  - Do not remove the screws completely from 3.

Figure 1. Unpacking the economizer

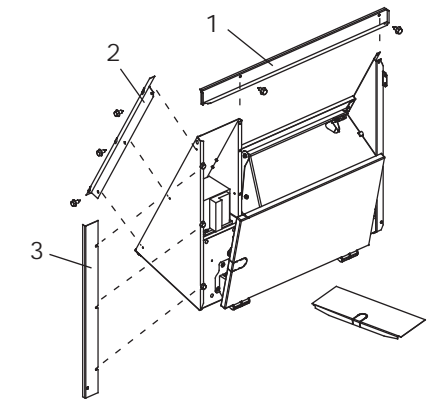

### 4 Assemble End Panel

- See Figure 2.  
 1. Align three slots in 4 with three tabs on 5.  
 2. Pivot 4 into place.  
 3. Align three tabs on 2 with three slots in 4.  
 4. Pivot 2 into place.  
 5. Secure 2 with three screws into 6.

Figure 2. Assembling the end panel

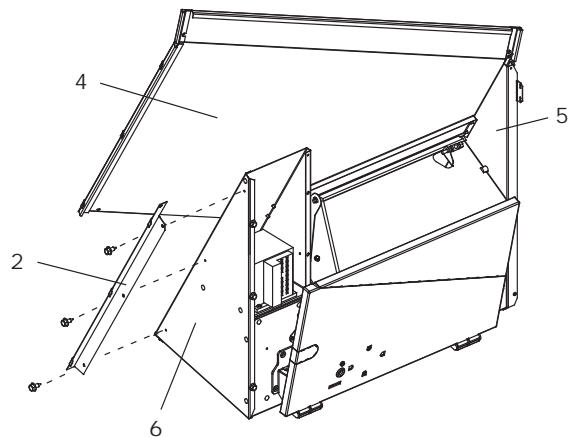

#### Reconfigure the Damper (for Horizontal Installation only)

- The economizer damper is pre-configured at the factory for down flow applications. You must reconfigure the damper for horizontal applications. See Figure 3 for disassembly.
1. Remove two screws from 7.
  2. Remove nut and disassemble 8.
  3. Remove six screws from 9 (three in each location).
  4. Make two cuts at 10.
  5. Detach and discard 11.

### 5 Figure 3. Disassembling the damper

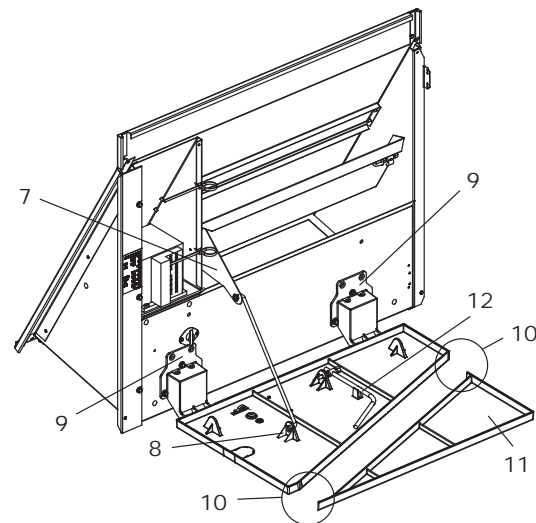

- See Figure 4 for reassembly.
1. Attach two screws at each location 9.
  2. Connect 12. Do not allow more than 0.25 in. (6.25 mm) of rod to protrude through the ball joint at 13.
  3. If the unit has a smoke detector, remove knockout 14.

### 6 Figure 4. Reassembling the damper

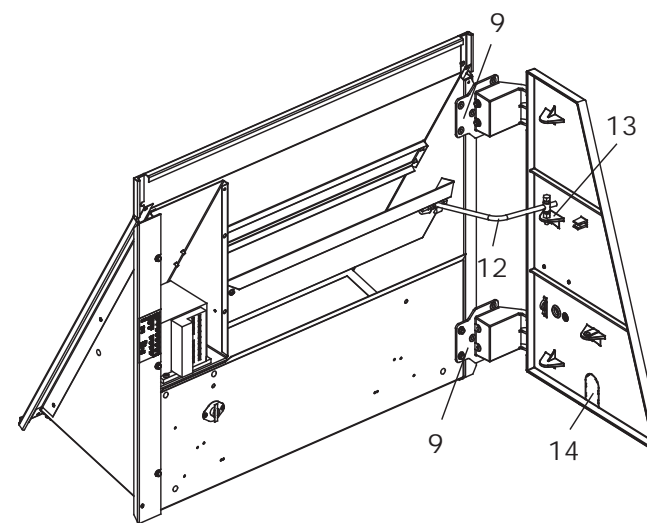

#### Install Optional Sensors (ReliaTel™ Only)

If the optional sensors for humidity and temperature monitoring are to be used (BAYENTH005\* and BAYENTH006\*), install them now using the instructions provided in the kits.

#### Install Duct Blockoff Plate (Downflow Units only)

- Important:** If power exhaust or barometric relief accessory kits are installed along with an economizer, do not install the duct blockoff plate.
- The duct blockoff plate is only installed on down flow units in a C, D or E cabinet (digit 30 = C/D/E). See Figure 5.
- For units without a smoke detector, install 15 with flange 16 pointing down.
  - For units with a smoke detector, remove knockout 17, and then install 15 with flange 16 pointing up.

### 7 Figure 5. Installing the duct blockoff plate

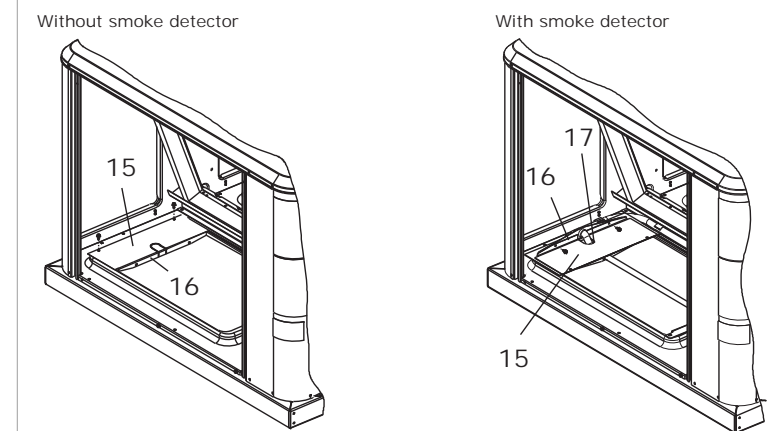

#### Install Economizer into the Rooftop Unit

- See Figure 1, Figure 6, and Figure 10.
1. Lift the assembled economizer unit into position.
  2. Fit the upper left hand corner around the channel in the cabinet post.
  3. Pivot the economizer into the opening in the cabinet.
  4. Lift the economizer and panel assembly to align the upper screw holes.
  5. Secure the top left and top right with screws.
  6. Pull out on the bottom of the economizer and secure it with the bottom three screws 23.
  7. Remove the filter access panel.
  8. Position 3 inside the filter section. 3 will slip over the three screws.
  9. Align the holes in the plate with the holes in the panel.
  10. Secure the bottom right with a screw 22.
  11. Install the bottom blockoff 21 and secure it with three screws 23.
  12. Using field supplied silicone, apply sealant around economizer hood 24.

8

Figure 6. Sealing the seams

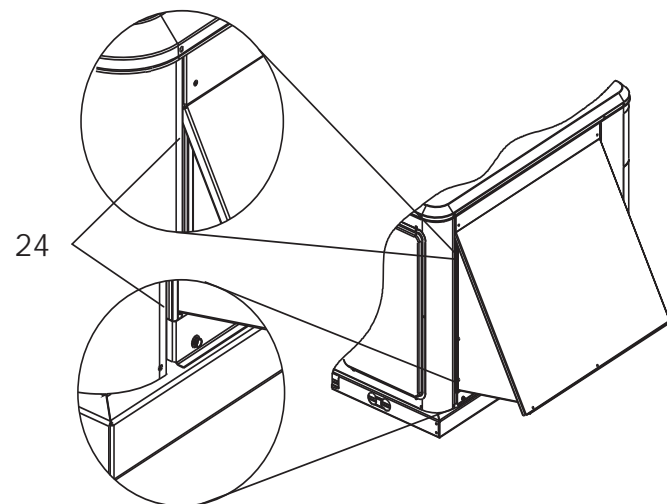

### Install Mixed Air Sensor

See Figure 7 and Figure 8.

1. Install 18 through 24 (if applicable) and secure it with 19.
2. Connect 20 to existing jumper connections located in the indoor fan section.

9

Figure 7. Mixed air sensor for units with forward curve fan

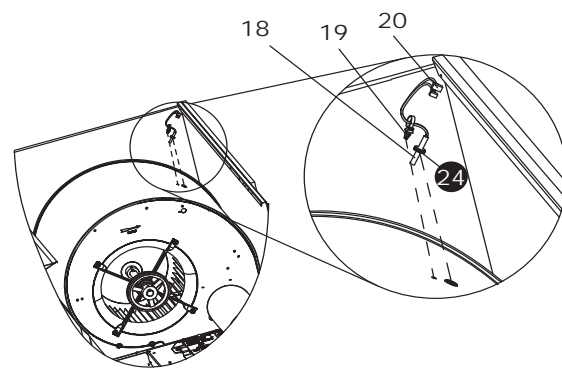
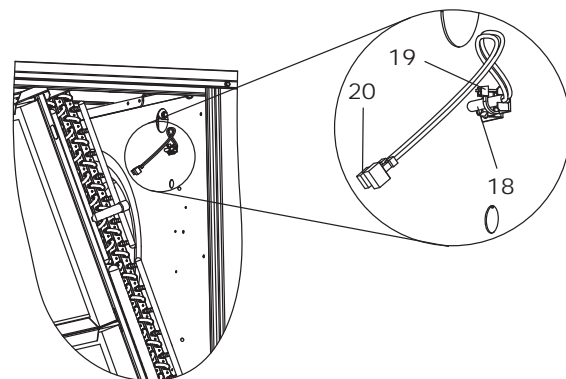

Figure 8. Mixed Air Sensor for units with Plenum fan



10

### Wiring Connections ReliaTel™ Units

Locate unit wiring harness plug P7 and insert into J7 on the actuator motor.  
**Note:** If options module (RTOM) is not installed then connect plug 3P4 to 3J4 on the refrigeration module (RTRM) in the control box.

### Electromechanical Units

Insert wiring harness plug PPM2A into the actuator motor wiring harness, and then replace the access panels.

### Factory Installed Economizer Set-Up

This section covers setup of economizer units that have been installed in the rooftop unit at the factory.

### Downflow Configuration

#### ⚠ WARNING

**Hazardous Voltage!**  
 Failure to disconnect power before servicing could result in death or serious injury. Disconnect all electric power, including remote disconnects before servicing. Follow proper lockout/tagout procedures to ensure the power can not be inadvertently energized.

See Figure 6, Figure 9, and Figure 10.

1. Remove filter access panel.
2. Remove the screw that holds it in place, and then remove bottom blockoff 21 from its shipping location.
3. Remove the bottom three screws from the economizer panel 23.
4. Pull the economizer assembly out into operating position.
5. Secure the economizer assembly with two screws 22 at the bottom of the corner posts.
6. Install 21 and secure with three screws 23.
7. Using field supplied silicone, apply sealant around economizer hood 24.

11

Figure 9. Removing the bottom blockoff

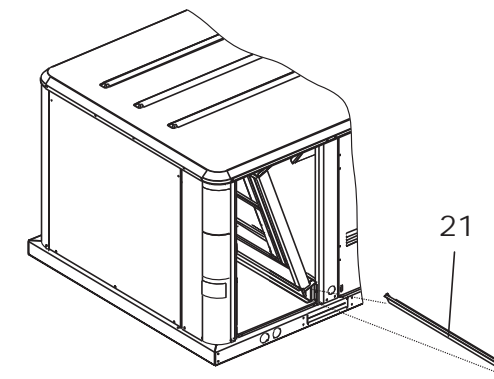
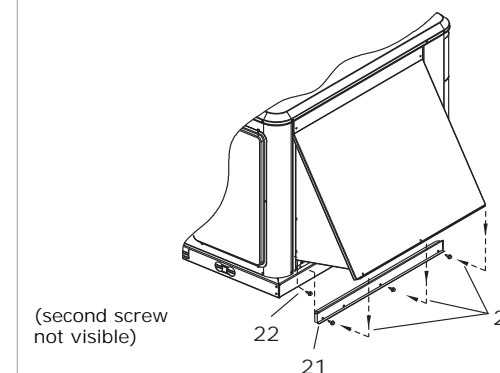

Figure 10. Fastening the economizer and bottom blockoff



12

### Horizontal Configuration

#### ⚠ WARNING

**Hazardous Voltage!**  
 Failure to disconnect power before servicing could result in death or serious injury. Disconnect all electric power, including remote disconnects before servicing. Follow proper lockout/tagout procedures to ensure the power can not be inadvertently energized.

The economizer must be removed from the rooftop unit and reconfigured for horizontal operation.

1. Remove filter access panel.
2. Remove 2, shown in Figure 1. (Leave the screws loosely in place.)
3. Remove the bottom three screws and top two screws from the economizer panel.
4. Remove 15, shown in Figure 5.
5. Pull the economizer assembly and end panel out of the unit.
6. Reconfigure the damper for horizontal operation. See "Reconfigure the Damper (for Horizontal Installation only)" for instructions, and then return to this procedure.
7. ReliaTel™ units only: If optional sensors for humidity and temperature monitoring are to be used (BAYENTH005\* and BAYENTH006\*), install them now. Use the instructions provided in the kits.
8. Remove supply and return duct covers from the horizontal openings and install over the downflow opening.
9. Reinstall the economizer. See "Install Economizer into the Rooftop Unit" for instructions.

### Minimum Position Setting for 1 Speed Indoor Fan

1. Apply power to the unit.
2. Place the zone sensor fan selector in the fan "ON" position and the heat/cool selector in the "OFF" position to place the damper in the minimum ventilation position.
3. Turn the Min Pos potentiometer (on the roof top economizer module [RTEM]) clockwise to open or counterclockwise to close. The damper will open to this setting each time the blower circuit is energized. When adjusting minimum position, the damper may move to the new setting in several small steps.
4. Wait at least 15 seconds for the damper to settle at the new position.
5. Replace the filter access panel. The damper will close when the blower circuit is de-energized.

13

### Minimum Position Setting for 7.5 to 10 tons and 17 Plus with Multi-Speed, Single Zone VAV or Variable Speed with eFlex™ and eDrive™ with Single Zone VAV

1. Apply power to the unit
2. Using the service test guide on unit access panel, momentarily jump across the Test 1 and Test 2 terminals on LTB1 one time to start indoor fan.
3. Turn the MIN POS - DCV potentiometer on the RTEM clockwise to open or counter-clockwise to close. The damper will open to this setting for low speed fan operation. When adjusting minimum position, the damper may move to the new setting in several small steps. Wait at least 15 seconds for the damper to settle at the new position. Range of damper for this setting is 0-100%.
4. Momentarily jump across the Test 1 and Test 2 terminals on LTB1, to cycle through test modes to Cool 1.
5. Turn the DCV SETPOINT - LL potentiometer on the RTEM clockwise to open or counter-clockwise to close. This will set the minimum damper position at an intermediate point of fan operation. Range of damper for this setting is 0-100%.
6. Momentarily jump across the Test 1 and Test 2 terminals on LTB1, to cycle through test modes to Cool 2.
7. Turn the MIN POS - DESIGN potentiometer on the RTEM clockwise to open or counter-clockwise to close. This will set the minimum damper position at maximum fan speed. Range of damper for this setting is 0-50%.
8. The economizer minimum damper position for all fan speeds is complete. The RTEM will control minimum damper position along an imaginary line between the 3 damper minimum positions based on fan speed.

**Note:** The RTEM will limit intermediate minimum damper position to ensure proper ventilation based upon the low fan speed minimum damper position set in Step 3.

9. Replace the filter access panel. The damper will close when the blower circuit is de-energized.

### Dry Bulb Settings

Standard economizer dry bulb changeover is field selectable to four outdoor temperatures. See the following table for potentiometer settings. The selection is made on the RTEM.

### Reference Enthalpy Settings

Economizer enthalpy changeover is field selectable to 4 points. See the following table for potentiometer settings. The selection is made on the RTEM.

14

Table 1. Potentiometer settings

Potentiometer Setting	Dry Bulb	Enthalpy
A	73°F (22.8°C)	27 Btu/lb (63 kJ/kg)
B	70°F (21.1°C)	25 Btu/lb (58 kJ/kg)
C	67°F <sup>(a)</sup> (19.4°C)	23 Btu/lb (53 kJ/kg)
D	63°F (17.2°C)	22 Btu/lb (51 kJ/kg)
E	55°F (12.8°C)	19 Btu/lb (44 kJ/kg)

(a) Factory setting

Table 2. Economizer option controls

Control Option	Enable Conditions <sup>(a)</sup>	Optional Sensors Required <sup>(b)</sup>
Dry Bulb (standard)	See Table 1	None
Reference Enthalpy (ReliaTel™ Only)	See Table 1	Outdoor Humidity (BAYENTH005*)
Comparative Enthalpy (ReliaTel™ Only)	Outdoor Air Enthalpy 3.0 BTU/lb. less than Return Air Enthalpy	Outdoor Humidity Return Humidity Return Temperature (BAYENTH006*)

(a) Economizing is enabled when these conditions are met.

(b) Conditions level will be self configured when optional sensors are connected.

Trane and American Standard create comfortable, energy efficient indoor environments for commercial and residential applications. For more information, please visit [trane.com](http://trane.com) or [americanstandardair.com](http://americanstandardair.com).

Trane and American Standard have a policy of continuous product and product data improvement and reserve the right to change design and specifications without notice. We are committed to using environmentally conscious print practices.