

## PROLINE® MASTER COMMERCIAL-GRADE RESIDENTIAL



### COMMERCIAL-GRADE HEATING ELEMENTS

- Dual 4500 watt elements for fast recovery and reliable operation\*
- Stainless steel upper & lower elements last longer than a standard copper element

### DYNACLEAN™ DIFFUSER DIP TUBE

- Helps reduce lime and sediment buildup and maximizes hot water output. Made from long-lasting PEX cross-linked polymer.

### HIGHER EFFICIENCY

- Eco-friendly non-CFC foam insulation, heat traps and other features combine to yield a higher Uniform Energy Factor that maximizes savings on operating costs

### COREGARD™ ANODE ROD

- Our anode rods have a stainless steel core that extends the life of the anode rod allowing superior tank protection far longer than standard anode rods.
- ProLine Master products have increased anode protection with either longer, or multiple anodes depending on model

### BLUE DIAMOND® GLASS COATING

- Provides superior corrosion resistance compared to industry standard glass lining
- Blue Diamond® Glass coating blend is formulated in the same lab that creates the protection for our industry-leading commercial product line

### ENHANCED-FLOW BRASS DRAIN VALVE

- Our residential water heaters have a solid brass, tamper resistant, enhanced-flow, ball type, drain valve
- Uses a standard female hose fitting that allows for fast and easy draining during maintenance

- Designed for easy operation, this valve includes an integral screwdriver slot that features a ¼ turn (open/close) radius, which not only permits full straight-through water flow but also a quick and positive shut off

### CODE COMPLIANCE

- Meets UBC and ICC National Codes and listed with CEC
- Complies with the Federal Energy Conservation Standards effective April 16, 2015, in accordance with the Energy Policy and Conservation Act (EPCA), as amended

### APPROVED FOR MANUFACTURED HOUSING

- All residential electric water heaters are compliant with HUD Standards for mobile homes/manufactured housing

### CERTIFIED TO UL 174 FOR HOUSEHOLD ELECTRIC WATER HEATERS

### CSA CERTIFIED AND ASME RATED T&P RELIEF VALVE

### DESIGN-LISTED BY UNDERWRITERS LABORATORIES

- Certified at 300 psi test pressure and 150 psi working pressure
- Listed according to UL 174 standards governing storage tank-type electric water heaters

### 8-YEAR LIMITED TANK AND PARTS WARRANTY



\* Standard wattage, other options available

Model Number	Nominal Capacity	Rated Storage Volume	First Hour Rating (Gallons)	UEF	Recovery @ 90°F Rise Gallon Per Hour	Element Wattage 240V			Dimensions in Inches			Approx. Shipping Weight (lbs)
						Standard	Minimum	Maximum	A	B	C	
<b>Tall Models</b>												
HNT-40	40	36	53	0.92	21	4500	3500	6000	61-1/4	53-1/4	18	118
HNT-50	50	46	62	0.92	21	4500	3000	6000	59	51-1/4	20-1/2	125
HNT-55	55	55	72	0.93	21	4500	2500	6000	56-1/2	48-1/2	24	145
<b>Short Models</b>												
HNS-40	40	37	55	0.92	21	4500	@ 4500	6000	50	40-3/4	20-1/2	109
HNS-40W	40	37	41	0.88	18	-	1000	4000	50	40-3/4	20-1/2	109
HNS-50	50	46	57	0.92	21	4500	2500	6000	49-3/4	40-3/8	23	161

Male 3/4" water connections on 8" center.

Models requiring a lower wattage than what is listed in the minimum wattage column and showing the @ symbol, will change to a "W" suffix model number.

"W" suffix models are available down to 1kW. (example: HNS-40 using 4,000 watt elements or less will become "HNS-40W").

Dimensions and specifications subject to change without notice in accordance with our policy of continuous product improvement.

Minimum wattage for HNT-50 is 3000 watts.

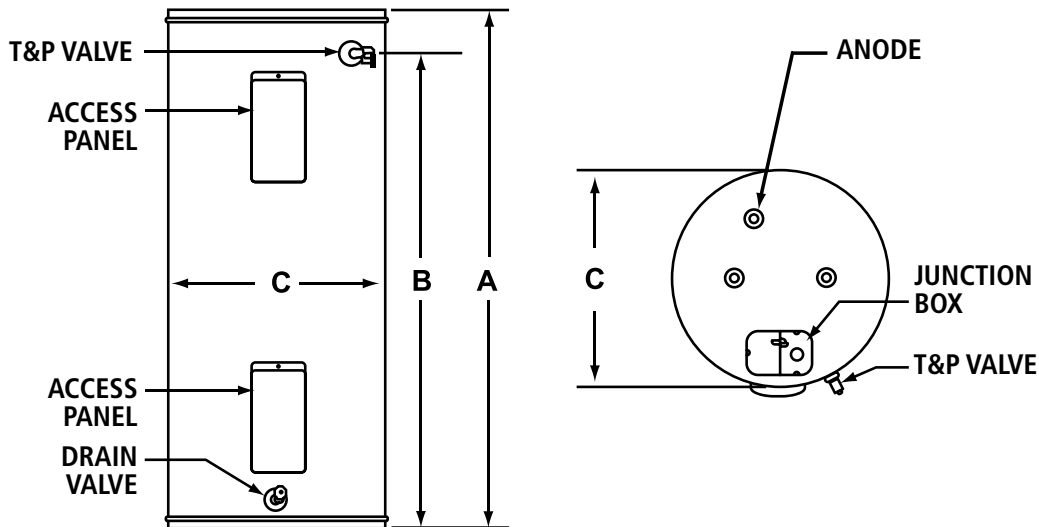

For technical information call 800-527-1953. A. O. Smith Corporation reserves the right to make product changes or improvements without prior notice.