



FULL PRODUCT LINE POCKET GUIDE

RESIDENTIAL & COMMERCIAL





The story is all in the details. Every water heater that carries the A. O. Smith name has a reputation to live up to, one that we've earned through 140 years of innovation. As an industry leader, we constantly look for new materials and develop new technologies that can improve energy efficiency. So, when you choose an A. O. Smith water heater, whether it's gas, electric or hybrid you can be confident that you are getting the best water heating solution regardless of the application—for today and for years to come. Innovation has a name... A. O. Smith.



All A. O. Smith residential water heaters meet the Federal Energy Efficiency Standards effective April 16, 2015, according to the National Appliance Energy Conservation Act (NAECA) of 1992, and meet the thermal efficiency and standby loss requirements of the U. S. Department of Energy and current edition of ASHRAE/IES 90.1. They also comply with the current edition of ICC Codes and the HUD Standards. Gas models meet American National Standards Institute Standards (ANSI Z21.10.1 - CSA 4.1) governing storage-type water heaters. Electric models are UL listed according to safety specifications outlined in Underwriters Laboratories, Inc. Standards for Safety (UL 174).

TABLE OF CONTENTS

Introduction	1
Table of Contents	2-4
Introducing the ProLine® Family.....	5
Contractor Rewards	6
ProLine® Family Features.....	7

RESIDENTIAL GAS

Vertex™ High Efficiency Power Vent	8-9
Vertex™ High Efficiency Power Direct Vent.....	10-11
Polaris® High Efficiency	12-13
ProLine® XE Non-Condensing Power Vent.....	14-15
ProLine® XE Non-Condensing Power Direct Vent	16-17
Effex® High Efficiency Atmospheric Vent.....	18-19
ProLine® XE High Efficiency Non-Condensing Flue Damper	20-21
ProLine® XE High Efficiency Non-Condensing Ultra-Low NOx Flue Damper.....	22-23
ProLine® XE High Efficiency Non-Condensing Ultra-Low NOx Power Vent.....	24-25
ProLine® Master Atmospheric Vent	26-29
ProLine® Master Ultra-Low NOx	30-31
ProLine® High Capacity Atmospheric Vent	32-33
ProLine® Direct Vent.....	34-35
ProLine® Atmospheric Vent	36-39
ProLine® Energy Saver Atmospheric Vent Mobile Home	40-41
ProLine® Energy Saver Direct Vent Mobile Home.....	42-43
ProLine® Ultra-Low NOx	44-45
ProLine® Ultra-Low NOx Direct Vent	46-47
ProLine® Ultra-Low NOx High Capacity.....	48-49

RESIDENTIAL HYBRID ELECTRIC

Voltex® Hybrid Electric Heat Pump - 10-Year Warranty	50-51
Voltex® Hybrid Electric Heat Pump.....	52-53

RESIDENTIAL ELECTRIC

ProLine® XE Self-Cleaning.....	54-55
ProLine® Master	46-57
ProLine® Standard.....	58-59
Mobile Home	60-61
ProLine® Specialty.....	62-63

TABLE OF CONTENTS

RESIDENTIAL PUMP AND EXPANSION TANKS

Pump Tanks.....	64-65
Expansion Tanks	66-67

TANKLESS (RESIDENTIAL AND COMMERCIAL)

ProLine® XE Condensing with Recirculation Pump.....	68-69
ProLine® XE Condensing High Efficiency.....	70-71
ProLine® XE Condensing High Efficiency.....	72-73
ProLine® XE Non-Condensing Concentric Vent.....	74-75
ProLine® XE Non-Condensing	76-77
ProLine® XE Non-Condensing Ultra-Low NOx.....	78-79
Non-Condensing Heavy-Duty.....	80-81
Rack System.....	82-85

BUILDING MANAGEMENT SYSTEM

BACnet and Modbus Interface	86-87
-----------------------------------	-------

COMMERCIAL GAS AND OIL FIRED

Cyclone® HE BTX-80	88-89
Cyclone® Xi BTX-100.....	90-91
Cyclone® Xi BTXL-100.....	92-93
Cyclone® MXi.....	94-97
Polaris® High Efficiency.....	98-99
Master-Fit® BTR.....	100-103
Master-Fit® Ultra-Low NOx	104-107
Conservationist® BT	108-109
Conservationist® Power Vent	110-111
Conservationist® Power Direct Vent	112-113
Conservationist® Ultra-Low NOx.....	114-115
Power Burner Light-Duty.....	116-117
Low NOx Power Burner.....	118-119
Conservationist® High Volume Power Burner	120-123
Conservationist® Duraclad Oil-Fired Tank-Type.....	124-125
Custom Heavy-Duty Large Volume Oil-Fired.....	126-129

TABLE OF CONTENTS

COMMERCIAL ELECTRIC

Light-Service	130-131
DEN/DEL Electric Dura-Power™	132-133
Gold Xi Series - DVE Electric.....	134-135
Gold Series - DRE Electric.....	136-137
Heavy-Duty Custom Xi	138-139
Heavy-Duty CMC/SU Booster Electric Dura-Power™	140-141
Heavy-Duty Premium Electric DVE/DHE Dura-Power™	142-145

CIRCULATING WATER HEATERS

XP High Efficiency Water Heater	146-149
XP ^{PLUS} High Efficiency Water Heater	150-153
Burkay® Genesis® Domestic Water Heater	154-155
Variable Fire™ High Efficiency Water Heater	156-157

HOT WATER SUPPLY BOILERS

Burkay® Energy Saver Copper Heat Exchanger	158-159
Burkay® HW Gas Domestic Water Heaters & Boiler.....	160-161

COMMERCIAL ELECTRIC BOILERS

Dura-Power™ NW Electric Boiler.....	162-165
-------------------------------------	---------

HOT WATER GENERATOR

Steam or Boiler Hot Water HWG Generator Systems	166-167
---	---------

COMMERCIAL STORAGE TANKS

Standard Jacketed Storage Tank.....	168-169
Custom-Line Factory Jacketed & Insulated Storage Tank	170-171
Uninsulated Standard Stock Bare Storage Tank.....	172-173
Heavy-Duty Large Volume Storage Tanks Model HD Custom-Built	174-177

COMMERCIAL WATER HEATERS

AC-U-Temp Complete Hot Water Systems	178
--	-----

INSTANTANEOUS

Semi-Instantaneous HWI Water Heaters	179
Xpert Water Heater Selection Tool	180



Introducing the ProLine® Family of Commercial-Grade Residential Water Heaters



ProLine® XE
Vertex™

ProLine® Master

ProLine®

When it comes to building a tough commercial-grade water heater, the keys to success are outstanding components and superior manufacturing capabilities. We've combined these two important elements to create the ProLine® Family of commercial-grade residential water heaters. This wholesale-channel exclusive will give A. O. Smith's contractors the ultimate advantage.

WHY PROFESSIONALS CHOOSE A. O. SMITH



EARN POINTS BY PURCHASING A. O. SMITH WATER HEATERS

It's free and easy to participate. Enroll online at contractorrewards.com. Eligible products will have a yellow reward code label worth valuable points. Two ways to enter the codes:

1. Download the smartphone app and scan the code.
2. Enter the code at contractorrewards.com.
3. Redeem your points on thousands of reward items.



**CONTRACTOR
REWARDS.COM**
Your Business. Your Choices. Your Rewards.

WITH OVER 1,000,000 MERCHANDISE ITEMS, YOUR REWARD CHOICES ARE ENDLESS.

A. O. SMITH PROVIDES 6 KEY THINGS

TO HELP GROW YOUR BUSINESS & BECOME MORE PROFITABLE

1. Contractor Locator

A new online locator that drives thousands of consumers from our website right to our loyal contractors. Your company listing is free and generated for you when you participate in our Contractor Rewards™ program. * Visit hotwater.com/contractorlocator for more information.

2. Contractor Rewards Program

Our program rewards our loyal contractors for buying our products. Buy more and get rewarded with prizes and higher status on our Contractor Locator.

3. Contractor Advertising Tools

Our Advertising Resource Center allows contractors to develop an easy, affordable and custom advertising campaign to promote their business. Go to www.hotwater.com/ads.

4. Breadth of Product Line

Residential or commercial, we have the most complete line from standard models to the most innovative high efficiency water heaters available.

5. Product Sales Tools

We provide contractors access to the sales tools needed to close more sales.

6. Brand Support

Marketing investment in our brand drives consumers to recognize our name, visit our website, locate local contractors and request products.

*To be listed on the Contractor Locator you must meet the minimum threshold of codes entered at contractorrewards.com

Visit hotwater.com/contractor to learn more.

A. O. SMITH WATER HEATERS

PREMIUM FEATURES. COMMERCIAL- GRADE RESIDENTIAL WATER HEATERS.



	PROLINE GOOD	PROLINE MASTER BETTER	PROLINE XE BEST
OPERATING COST	\$\$\$	\$\$	\$
INSTALLATION SPACE REQUIRED	■ to ■■	■■	■ to ■■■
WARRANTY COVERAGE (YEARS)	6	8	6-15

PREMIUM FEATURES:

Blue Diamond® Glass Coating**	•	•	•
DynaClean™ Automatic Sediment-Cleaning System**	•	•	•
Self-Powered Electronic Gas Valve*	•	•	•
Heat Trap Nipples**	•	•	•
Enhanced Flow Brass Drain Valve**	•	•	•
CoreGard™ Advanced Anode Rod Protection**	•	••	••
Energy Saving	Meets Requirement	Meets Requirement	•
Double Long Life Elements***		•	•
Electronic User Interface			•
Condensing Combustion*			•
Continuous Flow*			•
Cutting-Edge Technology Industry-Leading Efficiency			•

* These features apply to gas products only

** These features apply to tank-type products only

*** These features apply to electric products only

Hot Water Output, Cost of Operation & Installation Space Required estimated based on typical applications/installations. For a more custom analysis of unique installations, visit hotwater.com and use our product selector tool.



VERTEX™ HIGH EFFICIENCY POWER VENT



Power Vent Design for Installation Versatility

- Helical internal heat exchanger achieves 90% thermal efficiency, which saves money on operating costs compared to a standard 80% efficient gas water heater.
- Combined horizontal and vertical vent runs terminating through an outside wall, using Schedule 40 PVC pipe as follows:
 - 2" pipe allows vent runs up to 25 equivalent feet.
 - 3" pipe allows vent runs up to 65 equivalent feet.
 - 4" pipe allows vent runs up to 128 equivalent feet.

Side-Mounted Taps for Recirculating Systems

- Hot and cold "side taps" allow Vertex Power Vent to be used for combination space/water heating applications.

Intelli-Vent™ Gas Control with Silicon Nitride Hot Surface Ignitor

- Premium-grade hot surface ignitor eliminates standing pilot.
- Electronic circuitry provides superior system diagnostics capabilities plus extremely precise temperature control.

Blue Diamond® Glass Coating with Two Heavy Duty Anode Rods

- Provides superior corrosion resistance compared to the industry-standard glass lining.

Green Choice® Gas Burner

- Patented eco-friendly burner design reduces NOx emissions by up to 33% and complies with Low-NOx emission requirements of less than 40 ng/J.

Dynaclean™ Diffuser Dip Tube

CSA Certified and ASME Rated T&P Relief Valve

Maximum Hydrostatic Working Pressure: 150 psi

Code Compliance

- Meets UBC, CEC and ICC National Codes.
- Meets the thermal efficiency and standby loss requirements of the U.S. Department of Energy and current edition of ASHRAE/IES 90.1.

6-Year Limited Tank and Parts Warranty

- For complete information, consult written warranty or go to hotwater.com.

*Intelli-Vent™ is a registered trademark of Emerson Electric Company

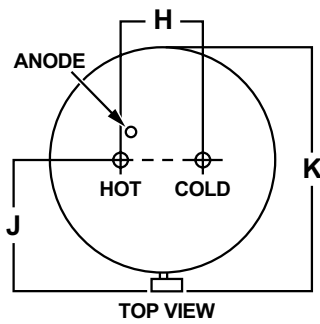

* INSTALL IN ACCORDANCE WITH LOCAL CODES

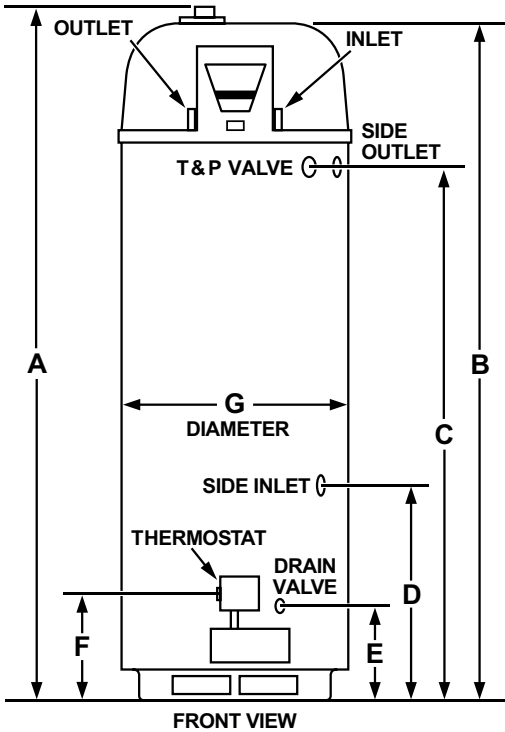

Model Number	Nominal Capacity	Rated Storage Volume	First Hour Rating (Gallons)	UEF	Thermal Efficiency	Recovery @ 90°F Rise Gallon Per Hour	BTU Input Per Hour
GPHE-50	50	48	119	0.88	90%	92	76,000

Model Number	Dimensions in Inches										Approx. Shipping Weight (lbs)
	A	B	C	D	E	F	G	H	J	K	
GPHE-50	71-1/8	68-5/8	52	21	9-1/8	12	22	8	15-3/4	27	210

Available in natural gas only.

Standard model certified for sea level to 5,300 ft. elevation. Order SMR K30 for elevations to 10,100 ft.

Optional Condensate Neutralizer Kit available (Part Number 100112380).

VERTEX™ HIGH EFFICIENCY POWER DIRECT VENT



GDHE-75



Condensing Design

- Operates at 96% thermal efficiency, which saves money on operating costs compared to a standard 80% efficient gas water heater.
- Equipped with condensate drain tee.

Helical Internal Heat Exchanger

- Spiral heat exchanger keeps hot combustion gases in the tank longer to lengthen the heat transfer cycle.

Power Direct Vent Design

- Combined vertical and horizontal runs terminating through an outside wall. Vents using PVC, CPVC or ABS pipe.
 - 2" pipe, vents up to 45 equivalent feet.
 - 3" pipe, vents up to 128 equivalent feet.

Side-Mounted Hot and Cold Recirculating Taps

- Allows Vertex to be installed as part of combination space heating/water heating applications.

Advanced Electronic Control

- Large LCD display.
- Precise temperature control.
- Advanced diagnostics.
- iCOMM™ compatible and can be monitored from remote locations: Call 1.888.WATER02 for more information.

Code Compliance

- Complies with SCAQMD Rule 1146.2 and other air quality management districts with similar requirements for Ultra-Low NOx emissions requirements of 14 ng/J or 20 PPM.
- Meets UBC, CEC and ICC National Codes.
- Meets the thermal efficiency and standby loss requirements of the U. S. Department of Energy and current edition of ASHRAE/IES 90.1.

Design-Listed by CSA International

- Certified at 300 psi test pressure and 150 psi working pressure.
- Listed according to ANSI Z21.10.1-CSA 4.1 standards governing storage tank-type water heaters.

6-Year Limited Tank and Parts Warranty

- For complete information, consult written warranty or go to hotwater.com.

ROUGH IN DIMENSIONS: 50 GALLON UNIT

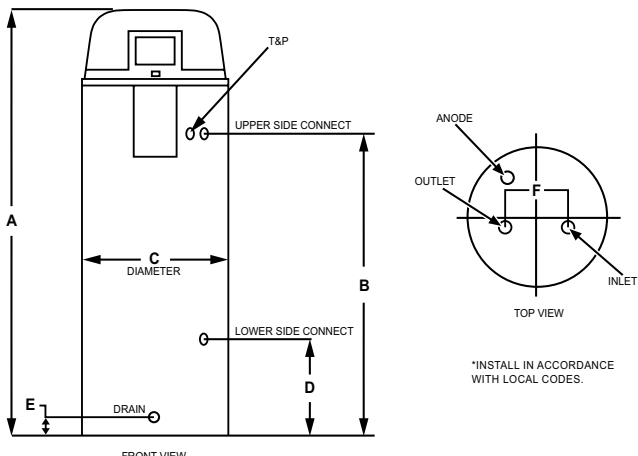

ROUGH IN DIMENSIONS: 75 GALLON UNIT

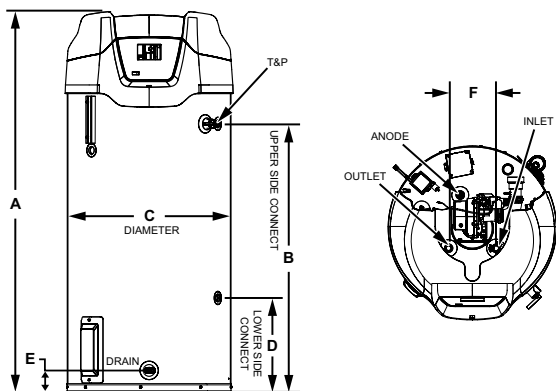

Model Number	Nominal Capacity	Rated Storage Volume	First Hour Rating (Gallons)	UEF	Thermal Efficiency	Recovery @ 90°F Rise Gallon Per Hour	BTU Input Per Hour
GDHE-50	50	49	100	0.88	96%	129	100,000
GDHE-75	75	74	130	0.86	96%	129	100,000

Model Number	Vent Size	Dimensions in Inches						Approx. Shipping Weight (lbs)
		A	B	C	D	E	F	
GDHE-50	2 or 3	66-3/4	49-1/4	22	15-3/4	3	8	255
GDHE-75	2 or 3	65-1/4	45-5/8	27-3/4	16	3-3/4	8	382

Available in Propane (LP) gas. Specify when ordering propane (LP) gas.
 Models certified for sea level to 10,100 ft. elevation.
 Optional Condensate Neutralizer Kit available (part number 100112380).

RESIDENTIAL GAS

POLARIS® HIGH EFFICIENCY



Condensing Design

- Operates at up to 96% thermal efficiency which saves money on operating costs compared to a standard 80% efficient gas water heater.
- Helical internal heat exchanger keeps hot combustion gases in the tank longer to extract more heat into the water.
- Modulating burner maintains high efficiency operation at lower input rates.

Stainless Steel Construction

- Tank and helical heat exchanger are constructed from 444 stainless steel for excellent corrosion resistance without the need for an anode.

Whisper Quiet Operation

- Ultra quiet blower and burner minimize noise.

Power Direct Vent Design

- Direct vent using PVC, CPVC or ABS either thru-the-wall or thru-the-roof.
- Optional concentric vent kit

Advanced Electronic Control

- Large LCD display provides precise temperature control and advanced diagnostics.

Code Compliance

- Complies with SCAQMD Rule 1146.2 and other air quality management districts with similar requirements for Ultra-Low NOx emissions requirements of 14 ng/J or 20 PPM.
- Meets UBC, CEC, and ICC National Codes.
- Meets the thermal efficiency and standby loss requirements of the U. S. Department of Energy and current edition of ASHRAE/IES 90.1.

10-Year Limited Tank and 1-Year Parts Warranty

- For complete information, consult written warranty or go to hotwater.com.

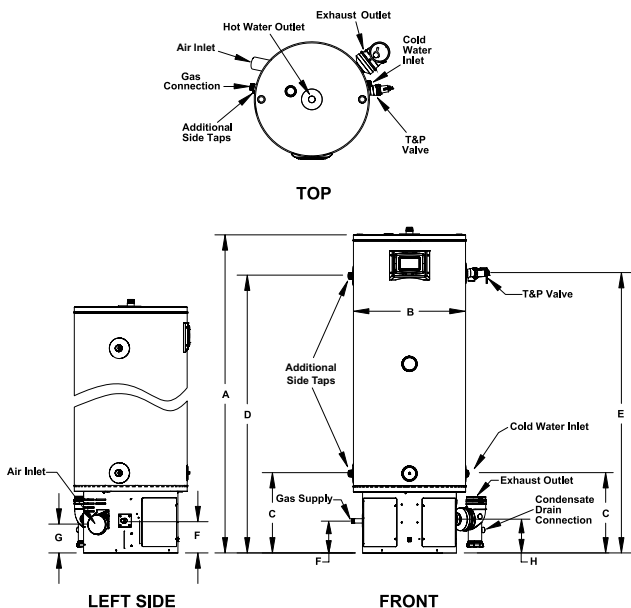

Model Number	Nominal Capacity	Rated Storage Volume	First Hour Rating (Gallons)	UEF	Thermal Efficiency	Recovery @ 90° Rise Gallon Per Hour	BTU/h Input Gallon Per Hour
GSP 100	34	33	170	0.90	96%	129	100,000
GSP 130	34	N/A	N/A	N/A	96%	165	130,000
GSP 150	34	N/A	N/A	N/A	94%	190	150,000
GTP 130	50	N/A	N/A	N/A	95%	165	130,000
GTP 150	50	N/A	N/A	N/A	95%	190	150,000
GTP 175	50	N/A	N/A	N/A	96%	222	175,000
GTP 199	50	N/A	N/A	N/A	96%	253	199,000

Model Number	Dimensions in Inches		Vent Connection	1" Water Connections		T&P	Gas Supply*	Approx. Shipping Weight (lbs)
	A	B		C	D			
GSP 100	48-1/2	22	2 or 3	15-3/4	40-1/2	41	6-3/8	150
GSP 130	48-1/2	22	2 or 3	15-3/4	40-1/2	41	6-3/8	150
GSP 150	48-1/2	22	2 or 3	15-3/4	40-1/2	41	6-3/8	150
GTP 130	62-3/8	22	2 or 3	15-3/4	54-1/2	55	6-3/8	176
GTP 150	63-3/4	22	2 or 3	15-3/4	55-3/4	56-1/4	6-3/8	180
GTP 175	63-3/4	22	3	15-3/4	55-3/4	56-1/4	6-3/8	180
GTP 199	63-3/4	22	3	15-3/4	55-3/4	56-1/4	6-3/8	180

Available in Propane (LP) gas. Specify when ordering Propane (LP) gas.
Models certified for sea level to 7,700 ft. elevation.

PROLINE® XE NON-CONDENSING POWER VENT



Versatile Power Vent Design

- All models feature an exclusive 3-position rotatable blower outlet which adds flexibility.
- Combined horizontal and vertical vent runs up to 180 equivalent feet with 4" diameter venting (ABS, PVC, CPVC and polypropylene).
- All models are equipped with a protected sensor that detects the presence of flammable vapors and automatically disables the burner to prevent ignition.
- Air intake snorkel elevates the inlet location of combustion air to prevent flammable vapors from entering the sealed combustion chamber.

Hot Surface Ignitor

- More robust and reliable than standing pilot, and reduces energy consumption

Built-in Heat Traps on the Water Inlet and Outlet Reduce the Amount of Heat Lost Through Piping

2-Inch-Thick, "Environmentally Friendly" Foam Insulation Reduces the Amount of Heat Loss and Contributes to Overall Energy Efficiency

User-Friendly

- State-of-the-art electronic gas control provides more precise temperature control.
- LED control light displays operation status and diagnostics information.

Enhanced-Flow Brass Drain Valve Available in Natural Gas and Propane Code Compliance

- Meets UBC, CEC and HUD National Codes.
- Meets the thermal efficiency and standby loss requirements of the U.S. Department of Energy and current edition of ASHRAE/IES 90.1.
- Complies with the Federal Energy Conservation Standards effective April 16, 2015, in accordance with the Energy Policy and Conservation Act (EPCA) as amended.

Design-Listed by CSA International

- Certified at 300 psi test pressure and 150 psi working pressure.
- Listed according to ANSI Z21.10.1-CSA 4.1 standards governing storage tank-type water heaters.

6-Year Limited Tank and Parts Warranty

- For complete information, consult written warranty or go to hotwater.com.



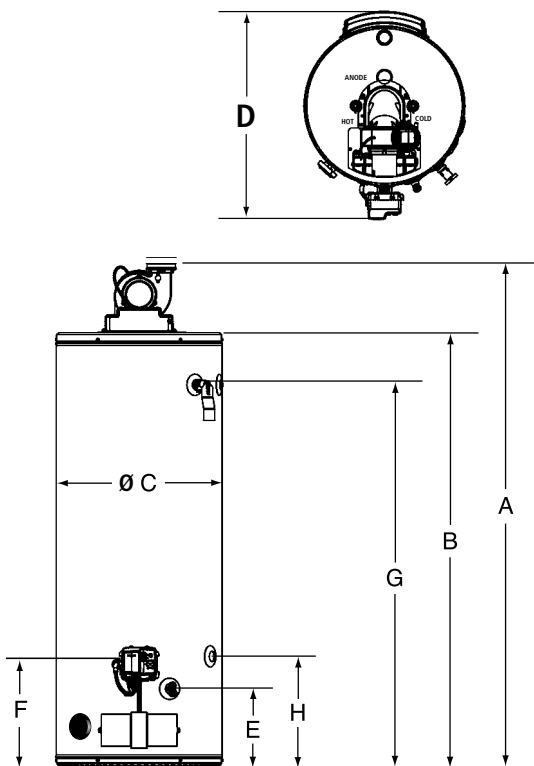

Model Number	Series	Nominal Capacity	Rated Storage Volume	UEF	First Hour Rating (Gallons)	Recovery @ 90°F Rise Gallon Per Hour	Input BTU/h
GPVL-40	200	40	38	0.67	72	45	40,000
GPVT-40	200	40	38	0.70	87	56	50,000
GPVL-50	200	50	49	0.72	79	45	40,000
GPVT-50	200	50	48	0.72	97	56	50,000
GPVX-50L	200	50	50	0.73	119	69	62,000
†GPVX-75L	210	75	72	0.69	116	80	76,000

Model Number	Dimensions in Inches								Approx. Shipping Weight (lbs)
	A	B	C	D	E	F	G	H	
GPVL-40	59	49-5/8	22	29-1/8	11	13-1/4	42-1/2	N/A	174
GPVT-40	68-1/2	59-1/4	20	27-1/8	11	13-1/4	53-1/8	15-1/4	176
GPVL-50	60-1/8	50-3/4	24	31-1/8	11	13-1/4	43-3/4	N/A	198
GPVT-50	68-1/8	58-3/4	22	29-1/8	11	13-1/4	51-3/4	15-1/4	192
GPVX-50L	61-1/8	52	24	31-1/8	11	13-1/4	44-1/2	15-1/4	212
†GPVX-75L	70-5/8	61-1/4	26	33-1/8	11	13-1/4	53	15-1/4	277

Available in propane (LP) gas. Specify when ordering propane (LP) gas.

Side connections are standard on GPVX models.

Side connections available on GPVT models. Add "L" to the model number (example: GPVT-40L).

All models are certified from sea level to 10,100 ft. elevation.

† GPVX-75L is not ENERGY STAR® Qualified.

PROLINE® XE NON-CONDENSING POWER DIRECT VENT



Power Direct Vent Design

- Combined horizontal and vertical vent runs up to 180 equivalent feet with 4" diameter venting (ABS, PVC, CPVC and polypropylene).
- Two-pipe sealed combustion system uses outside air, eliminating problems caused by insufficient indoor ventilation.

Green Choice® Gas Burner

- Patented eco-friendly burner design reduces NOx emissions by up to 33% and complies with Low-NOx emission requirements of less than 40 ng/J.

Hot Surface Ignitor

- More robust and reliable than standing pilot, and reduces energy consumption.

DynaClean™ Diffuser Dip Tube

User-Friendly

- State-of-the-art electronic gas control provides more precise temperature control.
- LED control light displays operation status and diagnostics information.

Enhanced-Flow Brass Drain Valve

CSA Certified and ASME Rated T&P Relief Valve

Code Compliance

- Meets UBC, CEC and HUD National Codes.
- Meets the thermal efficiency and standby loss requirements of the U.S. Department of Energy and current edition of ASHRAE/IES 90.1.
- Complies with the Federal Energy Conservation Standards effective April 16, 2015, in accordance with the Energy Policy and Conservation Act (EPCA) as amended.

Design-Listed by CSA International

- Certified at 300 psi test pressure and 150 psi working pressure.
- Listed according to ANSI Z21.10.1-CSA 4.1 standards governing storage tank-type water heaters.

6-Year Limited Tank and Parts Warranty

- For complete information, consult written warranty or go to hotwater.com.

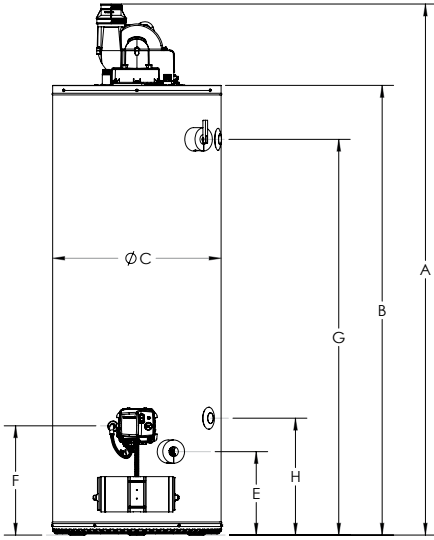
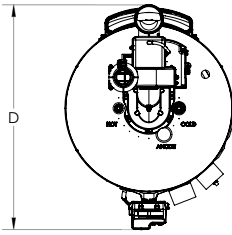

Model Number	Series	Nominal Capacity	Rated Storage Volume	UEF	First Hour Rating (Gallons)	Recovery @ 90°F Rise Gallon Per Hour	Input BTU/h
GPDL 40	200	40	38	0.68	74	45	40,000
GPDT 50	200	50	48	0.72	81	50	45,000
GPDX 50L	200	50	48	0.73	118	73	62,000**
† GPDX 75L	210	75	72	0.68	129	82	76,000

Model Number	Dimensions in Inches								Approx. Shipping Weight (lb)
	A	B	C	D	E	F	G	H	
GPDL 40	58-1/4	49-5/8	22	29-7/8	11	13-1/4	42-1/2	15-1/4	174
GPDT 50	67-1/2	58-3/4	22	29-7/8	11	13-1/4	51-3/4	15-1/4	192
GPDX 50L	69	60-1/4	22	29-7/8	11	13-1/4	52-3/4	15-1/4	200
† GPDX 75L	70-5/8	61-1/2	26	33-7/8	11	13-1/4	53	15-1/4	277

**Propane model has input of 58,000 BTU/hr.

Available in propane (LP) gas. Specify when ordering propane (LP) gas.

Side connections are standard on GPDX-50L and GPDX-75L.

Side connections available on GPDL-40 and GPDT-50. Add "L" to the model number (example: GPDT-50L).

All models are certified from sea level to 10,100 ft. elevation.

† GPVX-75 is not ENERGY STAR® Qualified.

RESIDENTIAL GAS

EFFEX® HIGH EFFICIENCY ATMOSPHERIC VENT



Pressurized Combustion System

Installation Friendly

- Allows for easy replacement of standard atmospheric vent heaters.
- Easily connects to existing B-vent.

Fan-Assisted, Category 1 Appliance

- Plugs into standard 110/120V outlet (10 foot power cord included).

24V Electronic Controls

Electronic Ignition

LCD User Interface

- Easy-to-read, eye level display.
- Simple temperature settings and adjustments.
- Service diagnostics are in plain text.

Powered Anode Rod

Enhanced-Flow Brass Drain Valve

DynaClean™ Diffuser Dip Tube

Green Choice® Gas Burner

- Patented eco-friendly gas burner design reduces NOx emissions by up to 33% and complies with Low-NOx emission requirements of less than 40 ng/J.

Code Compliance

- Meets UBC, CEC and HUD National Codes.
- Meets the thermal efficiency and standby loss requirements of the U. S. Department of Energy and current edition of ASHRAE/IESNA90.1.
- Complies with the Federal Energy Conservation Standards effective April 16, 2015, in accordance with the Energy Policy and Conservation Act, (EPCA), as amended.

Design-Certified by CSA International

- Certified at 300 psi test pressure and 150 psi working pressure. Listed according to ANSI Z21.10.1-CSA 4.1 standards governing storage tank-type gas water heaters.

6-Year Limited Tank and Parts Warranty

- For complete information, consult written warranty or go to hotwater.com.

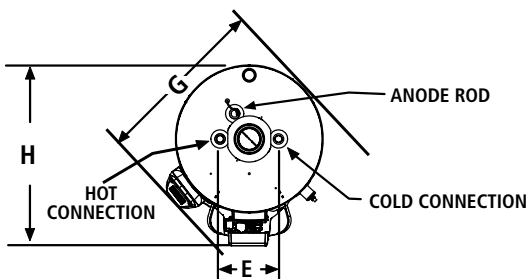

TOP VIEW

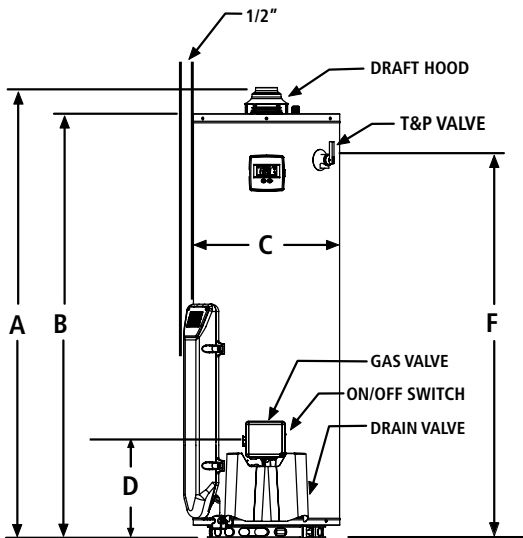

FRONT VIEW

Model Number	Nominal Gallon Capacity	Rated Storage Volume	First Hour Rating (Gallons)	UEF	BTU Input Gallon Per Hour	Recovery @ 90°F Rise Gallon Per Hour	Approx. Shipping Weight (lbs)
GAHH-40	40	38	68	0.66	40,000	43	157
GAHH-50	50	48	80	0.72	40,000	43	171

Model Number	Dimensions in Inches								Draft Hood
	A	B	C	D	E	F	G	H	
GAHH-40	61-3/4	58	20	13-1/4	8	51-1/2	23-1/4	25	3 or 4
GAHH-50	60-5/8	57-1/8	22	13-1/4	8	50-1/2	25-1/4	27	3 or 4

Available in natural gas only.

Water connection is 3/4" on all models.

All models are certified from sea level to 10,100 ft. elevation.

Requires 120 VAC power supply.

RESIDENTIAL GAS

PROLINE® XE HIGH EFFICIENCY NON-CONDENSING FLUE DAMPER



Automatic Flue Damper

- Increases efficiency as it automatically opens and closes to reduce heat loss in the standby mode.

Electronic Gas Control

Diagnostics

Electronic Ignition

Dynaclean™ Diffuser Dip Tube

Green Choice® Gas Burner

- Patented eco-friendly burner design reduces NOx emissions by up to 33% and complies with Low-NOx emission requirements of less than 40 ng/J.

CoreGard™ Anode Rod

Enhanced-Flow Brass Drain Valve

Blue Diamond® Glass Coating

CSA Certified And ASME RATED T&P Relief Valve

Code Compliance

- Meets UBC, CEC and HUD National Codes.
- Meets the thermal efficiency and standby loss requirements of the U.S. Department of Energy and current edition of ASHRAE/IES 90.1.
- Complies with the Federal Energy Conservation Standards effective April 16, 2015, in accordance with the Energy Policy and Conservation Act, (EPCA), as amended.

Design-Certified by CSA International

- Certified at 300 psi test pressure and 150 psi working pressure.
- Listed according to ANSI Z21.10.1 - CSA 4.1 standards governing storage tank-type water heaters.

6-Year Limited Tank and Parts Warranty

- For complete information, consult written warranty or go to hotwater.com.

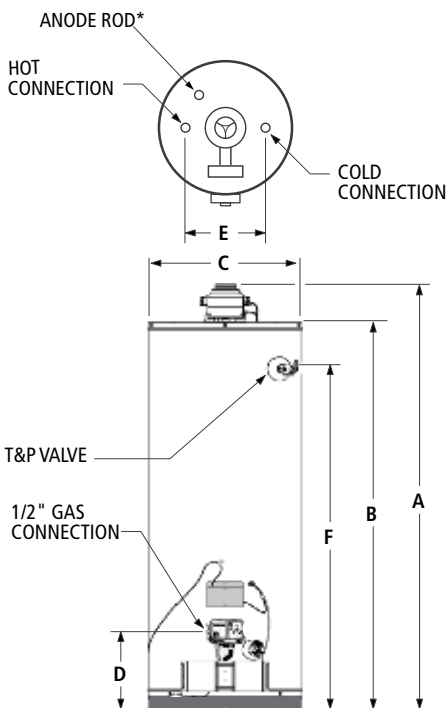

* Location for optional top-mounted T&P Valve if ordered from factory.

Maximum Hydrostatic Working Pressure: 150 PSI.

Model Number	Nominal Capacity	Rated Storage Volume	First Hour Rating (Gallons)	UEF	BTU Input Gallon Per Hour Natural*	Recovery @ 90°F Rise Gallon Per Hour	Approx. Shipping Weight (lbs)
Tall Models							
GCF-40	40	38	70	0.64	40,000	42	152
GCF-50	50	48	84	0.69	40,000	42	167
Short Models							
GCFL-40	40	38	65	0.66	40,000	42	149
*GCFL-50	50	49	78	0.69	40,000	42	175

Model Number	Dimensions in Inches							Draft Hood Outlet
	Foam Thickness	A	B	C	D	E	F	
Tall Models								
GCF-40	2	64-1/4	58-1/4	20	13	8	51-3/4	3 or 4
GCF-50	2	63-1/2	57-1/4	22	13	8	50-1/4	3 or 4
Short Models								
GCFL-40	2	54	47-3/4	22	13	8	41	3 or 4
*GCFL-50	2	55-3/4	49-1/2	24	13-1/4	8	42-1/2	3 or 4

Requires 120 VAC power supply.

Water connection is 3/4" on all models.

Specify when ordering Top T&P.

All models are certified from sea level to 10,100 ft. elevation.

*GCFL-50 available in natural gas only. All other models available in propane (LP) gas.

RESIDENTIAL GAS

PROLINE® XE HIGH EFFICIENCY NON-CONDENSING ULTRA-LOW NO_x FLUE DAMPER



ENERGY STAR® Efficiency

- Eco-friendly non-CFC foam insulation and an automatic flue damper increase efficiency to provide maximum household annual operating cost savings.

Green Choice® Gas Burner

- Enhanced Ultra-Low NO_x burner complies with SCAQMD Rule 1121 and other air quality management districts with similar requirements for NO_x emissions of less than 10ng/J.

Electronic Gas Control

DynaClean™ Diffuser Dip Tube

CoreGard™ Anode Rod

Blue Diamond® Glass Coating

Enhanced-Flow Brass Drain Valve

Requires 120V Power; 19.5 Ft Cord Included

Code Compliance

- Meets UBC, CEC, and HUD (excluding mobile homes) National Codes.
- Meets the thermal efficiency and standby loss requirements of the U.S. Department of Energy and current edition of ASHRAE/IES 90.1.
- Complies with the Federal Energy Conservation Standards effective April 16, 2015, in accordance with the Energy Policy and Conservation Act (EPCA), as amended.

CSA and Design-Certified by CSA International

- Certified at 300 psi test pressure and 150 psi working pressure.
- Listed according to ANSI Z21.10.1 – CSA 4.1 standards governing storage tank-type water heaters.

6-Year Limited Tank and Parts Warranty

- For complete information, consult written warranty or go to hotwater.com.

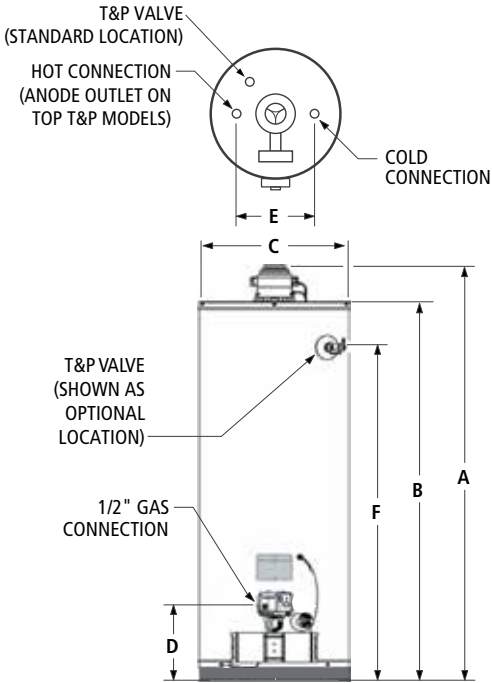

Maximum Hydrostatic Working Pressure: 150 PSI.

Model Number	Nominal Capacity	Rated Storage Volume	UEF	First Hour Rating (Gallons)	Recovery @ 90F Rise (Gallon/Hour)	BTU Input Natural Gas	Approx. Shipping Weight
GUF-40	40	38	0.65	68	42	40,000	152
GUF-50	50	48	0.70	83	42	40,000	167

Model Number	Dimensions in Inches							
	Foam Thickness	A	B	C	D	E	F	Draft Hood Outlet
GUF-40	2	64-1/4	58-1/4	20	13	8	51-3/4	3 or 4
GUF-50	2	63-1/2	57-1/4	22	13	8	50-1/4	3 or 4

Requires 120VAC power supply located within 19ft of the heater.
 Water connection is 3/4" on all models.
 Standard top T&P, specify when ordering side T&P.
 All models are certified from sea level to 7,800ft elevation.

RESIDENTIAL GAS

PROLINE® XE HIGH EFFICIENCY NON-CONDENSING ULTRA-LOW NO_x POWER VENT



Power Venting Made Simple

- Thru-the-wall or thru-the-roof power venting using either 2" or 3" PVC, ABS or CPVC vent pipe.

Intelli-Vent™ Gas Control

- Advanced electronics for more precise control of water temperature and easy to understand system diagnostics.

Combination Thermostat/ECO

- Utilizes an intermittent ignition gas valve (no standing pilot) with thermistor temperature sensor and built-in high temperature cut off.

Quiet and Efficient Blower

- Factory-installed 6-foot power cord with standard 3-prong male connector provided. Electrical requirements; 110/120 VAC power source less than 5 amp draw.

Dynaclean™ Diffuser Dip Tube

- Reduces lime and sediment buildup and maximizes hot water output. Made from long-lasting PEX cross-linked polymer.

Coregard™ Anode Rod

Green Choice® Gas Burner

- Complies with SCAQMD Rule 1121 and other air quality management districts with similar requirements for NO_x emissions of less than 10 ng/J.

Enhanced-Flow Brass Drain Valve

Code Compliance

- Meets UBC, CEC and HUD National Codes.
- Meets the thermal efficiency and standby loss requirements of the U. S. Department of Energy and current edition of ASHRAE/IES 90.1.
- Complies with the Federal Energy Conservation Standards effective April 16, 2015, in accordance with the Energy Policy and Conservation Act, (EPCA), as amended.

Design-Certified by CSA-International

- Certified at 300 psi test pressure and 150 psi working pressure.
- Listed according to ANSI Z21.10.1-CSA 4.1 standards governing storage tank-type gas water heaters.

6-Year Limited Tank and Parts Warranty

- For complete information, consult written warranty or go to hotwater.com

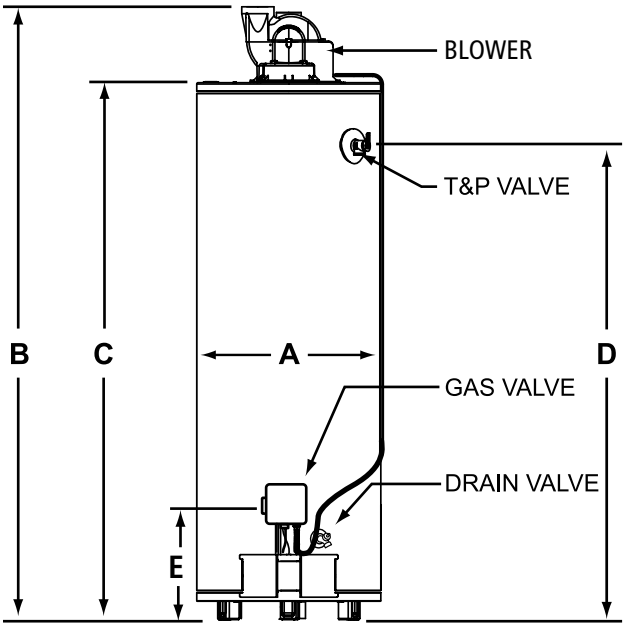
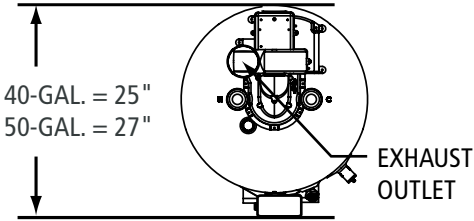

Model Number	Nominal Capacity	Rated Storage Volume	First Hour Rating (Gallons)	UEF	Recovery @ 90°F Rise Gallon Per Hour	BTU Input Gallon Per Hour	Approx. Shipping Weight (lbs)
GPNH-40	40	38	76	0.70	42.6	42,000	170
GPNH-50	50	48	71	0.65	42.6	42,000	207

Model Number	Dimensions in Inches					Draft Hood
	A	B	C	D	E	
GPNH-40	20	66-7/8	58-5/8	51-1/2	12-1/4	2 or 3
GPNH-50	22	66-7/8	57-7/16	51	12-1/4	2 or 3

No option available for top T&P valve.

RESIDENTIAL GAS

PROLINE® MASTER ATMOSPHERIC VENT



Intelligent Control Logic*

- The internal microprocessor provides enhanced operating parameters and tighter differentials for precise sensing and faster heating response to optimize performance.
- Uses a thermopile to generate the power needed to operate the electronic gas control without requiring an external power source.
- The electronic gas control incorporates an LED status indicator that monitors system operation and service diagnostics.

DynaClean™ Diffuser Dip Tube

CoreGard™ Anode Rod

- ProLine® Master products have increased anode protection with either longer or multiple anodes, depending on model.

Push-Button Piezo Ignitor

Enhanced-Flow Brass Drain Valve

Heat Trap Nipple

Blue Diamond® Glass Coating

- Blue Diamond® Glass Coating blend is formulated in the same lab that creates the protection for our industry-leading commercial product line.

Code Compliance

- Meets UBC, CEC and HUD National Codes.
- Meets the thermal efficiency and standby loss requirements of the U.S. Department of Energy and current edition of ASHRAE/IES 90.1.
- Complies with the Federal Energy Conservation Standards effective April 16, 2015, in accordance with the Energy Policy and Conservation Act (EPCA), as amended.

Design-Certified By CSA International

- Certified at 300 psi test pressure and 150 psi working pressure.
- Listed according to ANSI Z21.10.1-CSA 4.1 standards governing storage tank-type gas water heaters.

8-Year Limited Tank and Parts Warranty

- For complete information, consult written warranty or go to hotwater.com.

*Not available on 60,000 BTU input models (HWRT-50 and HWRX-55).

Model Number	Nominal Capacity	Rated Storage Volume	First Hour Rating Gallon	UEF	BTU Input Natural Gas	BTU Input Propane Gas	Recovery 90°F Rise Gallon Per Hour
Tall Models							
HWR-40	40	38	80	0.66	40,000	36,000	42
HWG-50	50	48	81	0.62	40,000	37,000	41
HWR-50	50	48	84	0.62	40,000	37,000	43
HWRT-50*	50	48	89	0.61	50,000	45,000	54
HWRX-55*	55	55	83	0.62	60,000	54,000	65
Short Models							
HWRL-40	40	38	67	0.59	40,000	36,000	41
HWRL-50	50	50	81	0.62	40,000	40,000	43

Water connection is ¾" on all models.

All models approved for installation from sea level to 10,100 ft. elevation.

Specify when ordering propane (LP) gas.

*For optional side-mounted recirculating taps, add "L" to the suffix in the model number.

Line drawings and dimensions on the following page.

RESIDENTIAL GAS

PROLINE® MASTER ATMOSPHERIC VENT (CONTINUED)

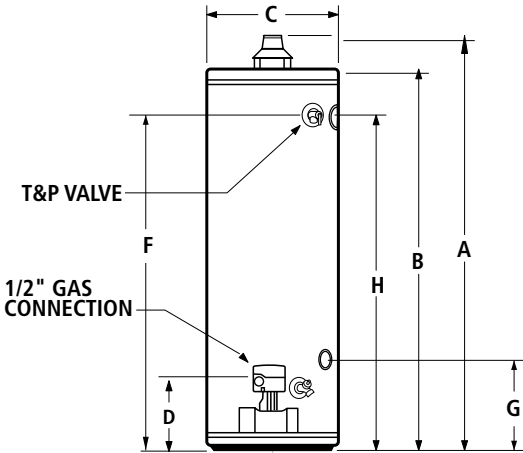
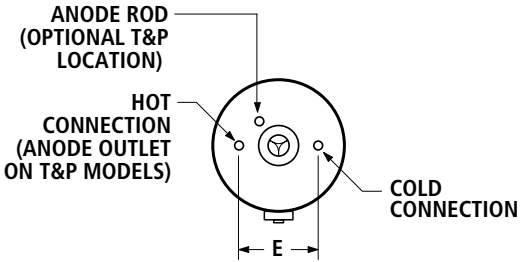

Maximum Hydrostatic Working Pressure: 150 PSI

Model Number	Dimensions in Inches				
	A	B	C	D	E
Tall Models					
HWR-40	61-3/4	58-1/4	20	12-1/4	8
HWG-50	60-3/4	57-1/4	21	12-1/4	8
HWR-50	60-3/4	57-1/4	22	12-1/4	8
HWRT-50*	60-3/4	57-1/4	22	12-1/4	8
HWRX-55*	59-3/4	55-1/4	24	13-1/2	8
Short Models					
HWRL-40	51-1/2	48	22	12	8
HWRL-50	53-1/4	49-3/4	24	12	8

Model Number	Dimensions in Inches				Approx. Shipping Weight (lbs)
	F	*G	*H	Draft Hood	
Tall Models					
HWR-40	52	N/A	N/A	3 or 4	138
HWG-50	50 1/2	N/A	N/A	3 or 4	148
HWR-50	50-1/2	N/A	N/A	3 or 4	165
HWRT-50*	50-1/2	14-1/4	50-1/2	4	165
HWRX-55*	48	14-1/4	48	4	185
Short Models					
HWRL-40	41-1/4	N/A	N/A	3 or 4	135
HWRL-50	41-3/8	N/A	N/A	3 or 4	177

Water connection is 3/4" on all models.

All models approved for installation from sea level to 10,100 ft. elevation.

Specify when ordering propane (LP) gas.

*For optional side-mounted recirculating taps, add "L" to the suffix in the model number.

RESIDENTIAL GAS

PROLINE® MASTER ULTRA-LOW NOx



The Electronic Gas Control Incorporates an LED Status Indicator that Monitors System Operation and Service Diagnostics

High Uniform Energy Factors (UEFs)

- Eco-Friendly non-CFC foam insulation, external heat traps and specially designed combustion chamber combine to produce a high UEF for maximum savings on operating costs.

Green Choice® Gas Burner

- Enhanced Ultra-Low NOx burner complies with SCAQMD Rule 1121 and other air quality management districts with similar requirements for NOx emissions of less than 10 ng/J.

DynaClean™ Diffuser Dip Tube

CoreGard™ Anode Rod

- ProLine® Master products have increased anode protection with either longer or multiple anodes, depending on model.

Push-Button Piezo Ignitor

Heat Trap Nipples

Blue Diamond® Glass Coating

- Blue Diamond® Glass Coating blend is formulated in the same lab that creates the protection for our industry-leading commercial product line.

Enhanced-Flow Brass Drain Valve

Code Compliance

- Meets UBC, CEC and HUD National Codes.
- Meets the thermal efficiency and standby loss requirements of the U.S. Department of Energy and current edition of ASHRAE/IES 90.1.
- Complies with the Federal Energy Conservation Standards effective April 16, 2015, in accordance with the Energy Policy and Conservation Act (EPCA), as amended.

CSA Certified by CSA International

Design-Certified by CSA International

- Certified at 300 psi test pressure and 150 psi working pressure. Listed according to ANSI Z21.10.1-CSA 4.1 standards governing storage tank-type gas water heaters.

8-Year Limited Tank and Parts Warranty

- For complete information, consult written warranty or go to hotwater.com.

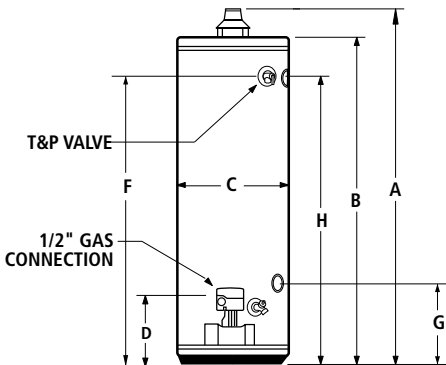
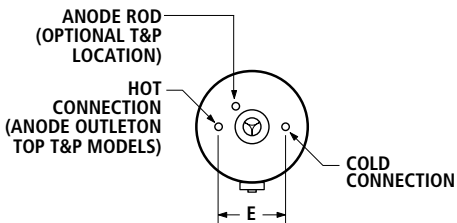

Maximum Hydrostatic Working Pressure: 150 PSI

Model Number	Nominal Capacity	Rated Storage Volume	First Hour Rating (Gallons)	UEF	BTU Input Natural Gas	Recovery @ 90°F Rise Gallon Per Hour	Approx. Shipping Weight (lbs)
Tall Models							
HUC-40	40	38	72	0.55	40,000	41	125
HUR-40	40	38	81	0.64	40,000	41	125
HUC-50	50	48	84	0.61	40,000	42	148
HUR-50	50	48	84	0.64	40,000	42	148
HURT-50L*	50	48	91	0.60	50,000	51	177
Short Models							
HURL-40	40	38	72	0.57	40,000	41	138

Model Number	Dimensions in Inches								
	A	B	C	D	E	F	G*	H*	Draft Hood
Tall Models									
HUC-40	62	58-1/4	18	12	8	52	N/A	N/A	3 or 4
HUR-40	62	58-1/4	20	12	8	52	N/A	N/A	3 or 4
HUC-50	60-3/4	57-1/4	20	12	8	50-1/2	N/A	N/A	3 or 4
HUR-50	60-3/4	57-1/4	22	12	8	50-1/2	N/A	N/A	3 or 4
HURT-50L*	61	57-1/2	22	11 1/4	8	50-1/2	12-1/4	50-1/2	4
Short Models									
HURL-40	51-1/2	47-3/4	22	12	8	41-1/4	N/A	N/A	3 or 4

All models may be ordered from the factory with top T&P.

Side loop connections are standard on model (HURT-50L).

Most models approved for installation from sea level to 7,700 ft. elevation (except on HURT-50L which is approved to 5,400 ft.).

RESIDENTIAL GAS

PROLINE® HIGH CAPACITY ATMOSPHERIC VENT



Highest Recoveries

- Capacity/input combinations up to 98 gallons/75,100 BTU's to produce recoveries up to 81 gallons per hour.

The Electronic Gas Control Incorporates an LED Status Indicator that Monitors System Operation and Service Diagnostics

Green Choice® Gas Burner

- Patented eco-friendly burner design reduces NOx emissions up to 33% and complies with Low-NOx emission requirements of 40 ng/J.

DynaClean™ Diffuser Dip Tube

CoreGard™ Anode Rod

Push-Button Piezo Ignitor

Blue Diamond® Glass Coating

Enhanced-Flow Brass Drain Valve

Code Compliance

- Meets UBC, CEC and ICC National Codes.
- Meets the thermal efficiency and standby loss requirements of the U.S. Department of Energy and current edition of ASHRAE/IES 90.1.

CSA Certified and ASME Rated T&P Relief Valve

Maximum Hydrostatic Working Pressure: 150 psi

Design-Certified By CSA International

- Certified at 300 psi test pressure and 150 psi working pressure.
- Listed according to ANSI Z21.10.1-CSA 4.1 standards governing storage tank-type gas water heaters.

6-Year Limited Tank and Parts Warranty

- For complete information, consult written warranty or go to hotwater.com.



TOP VIEW

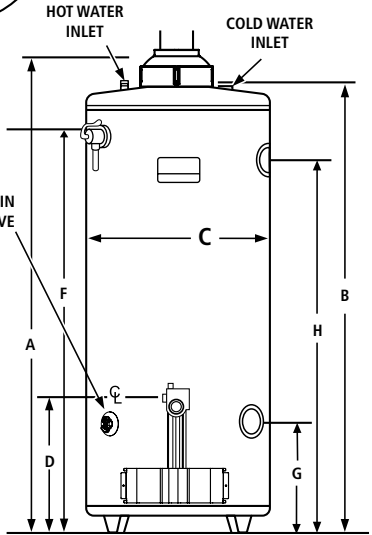
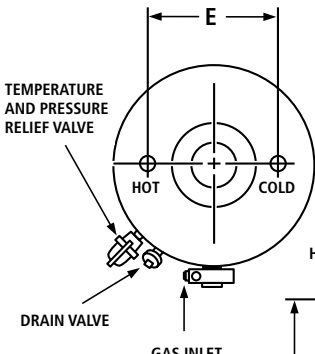

FRONT VIEW

Model Number	Nominal Capacity	Rated Storage Volume	UEF	First Hour Rating (Gallons)	Recovery @ 90°F Rise Gallon Per Hour	BTU Input Natural Gas
FCG-75	74	71	0.60	125	81	75,100
FCG-100	98	95	0.58	170	81	75,100

Model Number	Dimensions in Inches					Approx. Shipping Weight (lbs)
	A	B	C	D	E	
FCG-75	61	58-1/2	26-1/2	15-3/16	16	270
FCG-100	68-1/2	66-1/2	27-3/4	15-3/16	16	340

Model Number	Dimensions in Inches			
	F	G	H	Draft Hood
FCG-75	50-1/4	15-1/2	50-1/4	4
FCG-100	57-3/8	N/A	N/A	4

Water connections are 1" male NPT on FCG-75 and 1-1/4" on FCG-100.

For 10-year tank and 10-year parts limited warranty, change "F" to "P" in model number (example: PCG-75).

For optional side-mounted recirculating taps, add "L" to the suffix of the model number (example: FCG-75L).

Specify when ordering propane (LP) gas.

All models are certified from sea level to 7,700 ft. elevation.

RESIDENTIAL GAS

PROLINE® DIRECT VENT



Direct Vent Design

- One-pipe, dual-channel closed system draws all make-up air from outside the home, eliminating problems caused by insufficient indoor ventilation and is FVIR compliant.
- Horizontal air intake and venting on all models up to 80 inches from outside wall with no electrical power needed.

Intelligent Control Logic

Green Choice® Gas Burner

- Patented eco-friendly burner design reduces NOx emissions by up to 33% and complies with Low-NOx emission requirements of less than 40 ng/J.

DynaClean™ Diffuser Dip Tube

CoreGard™ Anode Rod

Push Button Piezo Ignitor

Heat Trap Nipples

Code Compliance

- Meets UBC, CEC and HUD National Codes.
- Meets the thermal efficiency and standby loss requirements of the U.S. Department of Energy and current edition of ASHRAE/IES 90.1
- Complies with the Federal Energy Conservation Standards effective April 16, 2015, in accordance with the Energy Policy and Conservation Act (EPCA), as amended.

Design-Certified by CSA International

- Certified at 300 psi test pressure and 150 psi working pressure. Listed according to ANSI Z21.10.1-CSA 4.1 standards governing storage tank-type gas water heaters.

6-Year Limited Tank and Parts Warranty

- For complete information, consult written warranty or go to hotwater.com.



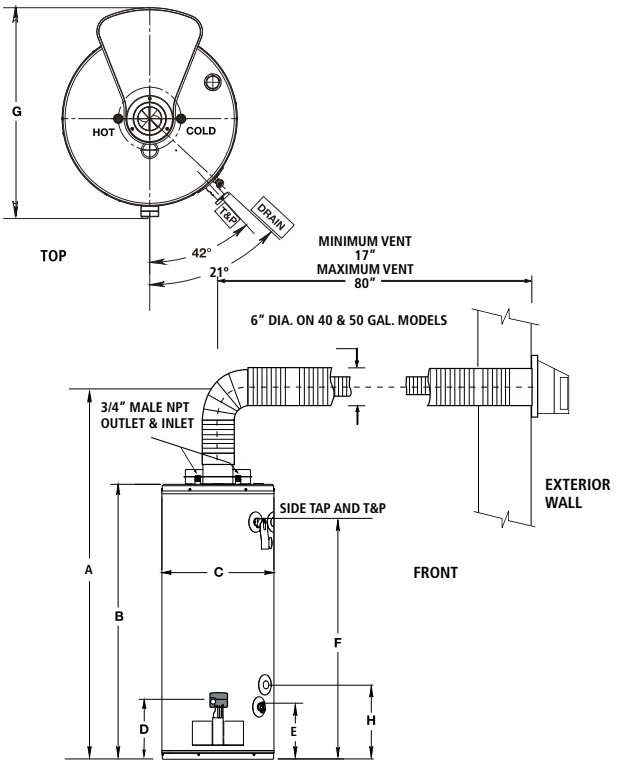

Model Number	Nominal Capacity	Rated Storage Volume	First Hour Rating (Gallons)	UEF	Input BTU Per Hour	Recovery 90°F Rise Gallon Per Hour	Vent Outlet
GDV-40	40	39	64	0.60	38,000	41	Co-Axial
GDV-50	50	48	77	0.66	40,000	43	Co-Axial
GDVT-50	50	48	83	0.65	47,000	51	Co-Axial

Model Number	Dimensions in Inches								Approx. Shipping Weight (lbs)
	A	B	C	D	E	F	*G	H	
GDV-40	64	49-3/4	22	13-1/4	15-1/4	42-1/2	29	15-1/4	178
GDV-50	73	59	22	13-1/4	15-1/4	51-3/4	29	15-1/4	200
GDVT-50	74	60	22	13-1/4	15-1/4	52-3/4	29	15-1/4	215

Dual-channel system has 3" vent pipe inside 6" air intake pipe, for the 40 and 50-gallon models.

All models have 2" foam cavity.

Water connection is 3/4" male on all models.

40 and 50 gallon models are 8" on center.

*Allow 29-1/2" for front to back dimension for gas control and air intake pipe at the rear of the heater.

All models are available in propane (LP) gas (series 301).

All models are certified from sea level to 7,700 ft. elevation.

All models available with side connections. Add "L" to the model number, example GDV-40L.

PROLINE® ATMOSPHERIC VENT



Intelligent Control Logic*

- The internal microprocessor provides enhanced operating parameters and tighter differentials for precise sensing and faster heating response to optimize performance.
- Uses a thermopile to generate the power needed to operate the electronic gas control without requiring an external power source.
- The electronic gas control incorporates an LED status indicator that monitors system operation and service diagnostics.
- *Not available on 60,000 BTU input models (GCRX-50 and GCRX-55).

DynaClean™ Diffuser Dip Tube

CoreGard™ Anode Rod

Push-Button Piezo Ignitor

Enhanced-Flow Brass Drain Valve

Heat Trap Nipple

Blue Diamond® Glass Coating

Code Compliance

- Meets UBC, CEC and HUD National Codes.
- Meets the thermal efficiency and standby loss requirements of the U.S. Department of Energy and current edition of ASHRAE/IES 90.1.
- Complies with the Federal Energy Conservation Standards effective April 16, 2015, in accordance with the Energy Policy and Conservation Act (EPCA), as amended.

Design-Certified By CSA International

- Certified at 300 psi test pressure and 150 psi working pressure.
- Listed according to ANSI Z21.10.1-CSA 4.1 standards governing storage tank-type gas water heaters.

6-Year Limited Tank and Parts Warranty

- For complete information, consult written warranty or go to hotwater.com.

Model Number	Nominal Gallon Capacity	Rated Storage Volume	First Hour Rating (Gallons)	UEF	BTU Input Natural Gas	BTU Input Propane Gas	Recovery 90°F Rise Gallon Per Hour
Tall Models							
†GCB-30	30	29	69	0.61	35,500	32,000	37
GCR-30	30	29	69	0.60	35,500	32,000	37
‡GCRH-40	40	38	65	0.61	35,500	N/A	38
†GCB-40	40	38	78	0.65	40,000	36,000	42
GCR-40*	40	38	80	0.66	40,000	36,000	42
GCG-50*	50	48	81	0.62	40,000	37,000	41
GCR-50*	50	48	84	0.62	40,000	37,000	43
GCRT-50*	50	48	89	0.61	50,000	45,000	54
†GCRX-50*	50	49	99	0.61	60,000	54,000	65
GCRX-55*	55	55	83	0.62	60,000	54,000	65
Short Models							
†GCBL-30	30	28	68	0.58	35,500	32,000	37
GCRL-30	30	28	66	0.59	35,500	32,000	36
†GCBL-40	40	38	68	0.57	40,000	36,000	41
GCRL-40	40	38	67	0.59	40,000	36,000	41
GCRL-50	50	50	81	0.62	40,000	40,000	43

Water connection is ¾" on all models.

For 10-year tank and 10-year parts warranty, change "G" to "X" in model number (example: XCR-30).

All models approved for installation from sea level to 10,100 ft. elevation.

† Models ship with supplied insulation blanket

Specify when ordering propane (LP) gas.

‡ LP models not available on GCRH-40

*For optional side-mounted recirculating taps, add "L" to the suffix in the model number.

Line drawings and dimensions on the following page.

RESIDENTIAL GAS

PROLINE®

ATMOSPHERIC VENT (CONTINUED)

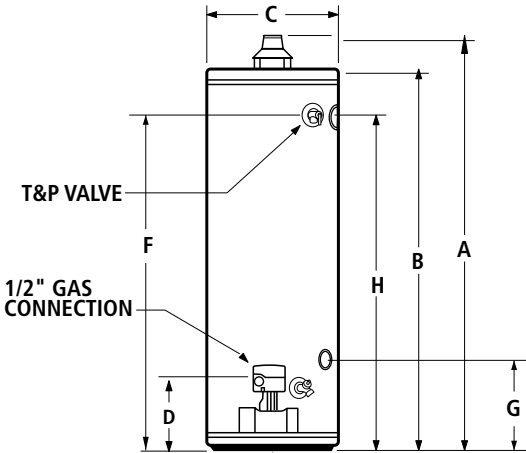
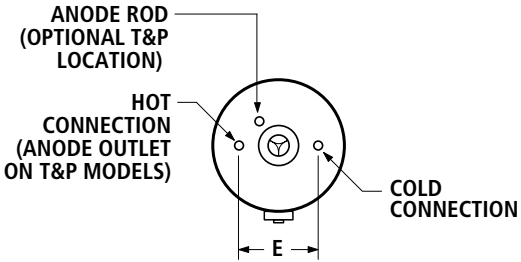

Maximum Hydrostatic Working Pressure: 150 PSI

Model Number	Dimensions in Inches				
	A	B	C	D	E
Tall Models					
†GCB-30	61-1/2	58	16	12-1/4	8
GCR-30	61-1/2	58	18	12-1/4	8
‡GCRH-40	61-3/4	58-1/4	20	12-1/4	8
†GCB-40	61-3/4	58-1/4	18	12-1/4	8
GCR-40*	61-3/4	58-1/4	20	12-1/4	8
GCG-50*	60-3/4	57-1/4	21	12-1/4	8
GCR-50*	60-3/4	57-1/4	22	12-1/4	8
GCRT-50*	60-3/4	57-1/4	22	12-1/4	8
†GCRX-50*	65-1/2	61	22	13-1/2	8
GCRX-55*	59-3/4	55-1/4	24	13-1/2	8
Short Models					
†GCBL-30	50	46-1/2	18	12	8
GCRL-30	50	46-1/2	20	12	8
†GCBL-40	51-1/2	48	20	12	8
GCRL-40	51-1/2	48	22	12	8
GCRL-50	53-1/4	49-3/4	24	13-1/4	8

Model Number	Dimensions in Inches				Approx. Shipping Weight (lbs)
	F	*G	*H	Draft Hood	
Tall Models					
†GCB-30	51-3/4	N/A	N/A	3 or 4	123
GCR-30	51-3/4	N/A	N/A	3 or 4	132
‡GCRH-40	52	N/A	N/A	3 or 4	138
†GCB-40	52	N/A	N/A	3 or 4	130
GCR-40*	52	14-1/4	51-3/4	3 or 4	138
GCG-50*	50 1/2	14-1/4	50-1/2	3 or 4	148
GCR-50*	50-1/2	14-1/4	50-1/2	3 or 4	165
GCRT-50*	50-1/2	14-1/4	50-1/2	4	165
†GCRX-50*	54-1/4	14-1/4	54-1/4	4	182
GCRX-55*	48	14-1/4	48	4	185
Short Models					
†GCBL-30	40	N/A	N/A	3 or 4	110
GCRL-30	40	N/A	N/A	3 or 4	118
†GCBL-40	41-1/4	N/A	N/A	3 or 4	134
GCRL-40	41-1/4	N/A	N/A	3 or 4	135
GCRL-50	41-3/8	N/A	N/A	3 or 4	177

Water connection is 3/4" on all models.

For 10-year tank and 10-year parts warranty, change "G" to "X" in model number (example: XCR-30).

All models approved for installation from sea level to 10,100 ft. elevation.

† Models ship with supplied insulation blanket

Specify when ordering propane (LP) gas.

‡ LP models not available on GCRH-40

*For optional side-mounted recirculating taps, add "L" to the suffix in the model number.

RESIDENTIAL GAS

PROLINE® ENERGY SAVER ATMOSPHERIC VENT MOBILE HOME



Complies with HUD Standards for Manufactured Housing Installation

Gas Control Convertible for Natural and Propane Gas

- For flexibility to meet the varying needs of manufactured housing installations.

Side-Mounted 3/4" Cold Water Inlets

- For flexibility to meet the varying needs of manufactured housing installations.
- Top-mounted 3/4" hot water outlet.

Green Choice® Gas Burner

- Patented eco-friendly burner design reduces NOx emissions by up to 33% and complies with Low-NOx emission requirements of less than 40 ng/l.

CoreGard™ Anode Rod

Blue Diamond® Glass Coating

Enhanced-Flow Brass Drain Valve

Code Compliance

- Meets UBC, CEC and HUD National Codes.
- Meets the thermal efficiency and standby loss requirements of the U.S. Department of Energy and current edition of ASHRAE/IES 90.1.
- Complies with the Federal Energy Conservation Standards effective April 16, 2015, in accordance with the Energy Policy and Conservation Act (EPCA), as amended.

Design-Certified by CSA International

- Certified at 300 psi test pressure and 150 psi working pressure.
- Listed according to ANSI Z21.10.1-CSA 4.1 standards governing storage tank-type gas water heaters.

CSA Certified and ASME Rated T&P Relief Valve

6-Year Limited Tank and 2-Year Limited Tank Parts Warranty

- For complete information, consult written warranty or go to hotwater.com.

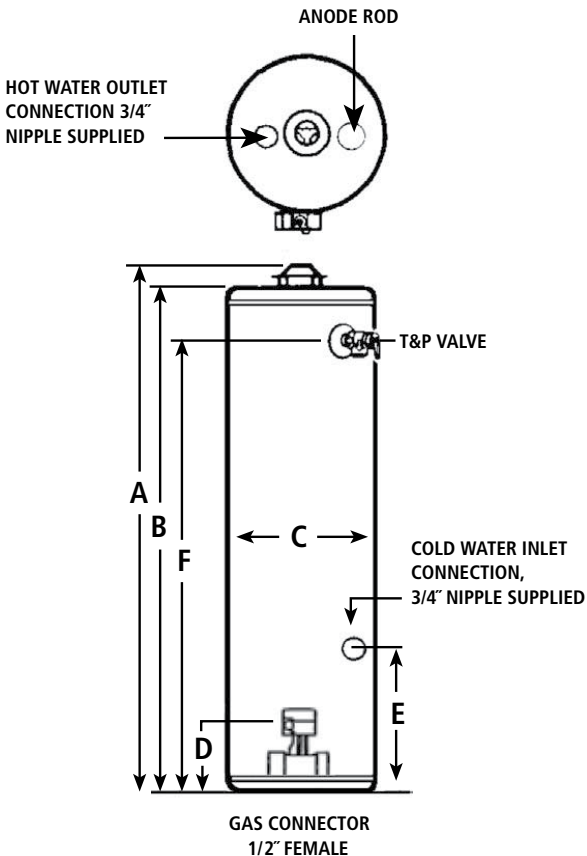

Model Number	Nominal Capacity	Rated Storage Volume	First Hour Rating (Gallons)	UEF	BTU Input Per Hour Natural Gas	BTU Input Per Hour Propane Gas	Recovery @ 90°F Rise Gallon Per Hour
FMHR-30	30	29	63	0.61	35,500	32,000	36
FMHR-40	40	38	59	0.58	35,500	32,000	36

Model Number	Dimensions in Inches						Draft Hood Outlet	Approx. Shipping Weight (lbs)
	A	B	C	D	E	F		
FMHR-30	61-1/2	58	18	13	14-1/4	52	3 or 4	129
FMHR-40	61-3/4	58-1/4	20	13	14-1/4	51-3/4	3 or 4	153

All models ship from factory for use with natural gas. A complete propane (LP) burner is supplied for converting to propane gas.

No option available for top T&P.

Certified from sea level to 10,100 ft. elevation.

PROLINE® ENERGY SAVER DIRECT VENT MOBILE HOME



Complies With HUD Standards For Manufactured Housing Installation

Gas Control Convertible for Natural and Propane Gas

- For flexibility to meet the varying needs of manufactured housing installations.

Direct Vent Models Package with Bottom Intake Air Vent

- To draw all combustion make-up air from outside the structure.

Optional Ducted Air Inlet Kit for Direct Vent Models

- For use when water heater is installed over a basement.
- Provision for horizontal air inlet ducting.

Side-Mounted 3/4" Cold Water Inlets

Green Choice® Gas Burner

- Patented eco-friendly burner design reduces NOx emissions by up to 33% and complies with Low-NOx emission requirements of less than 40 ng/J.

DynaClean™ Diffuser Dip Tube

CoreGard™ Anode Rod

Enhanced-Flow Brass Drain Valve

Blue Diamond® Glass Coating

Code Compliance

- Meets UBC, CEC and HUD National Codes.
- Meets the thermal efficiency and standby loss requirements of the U.S. Department of Energy and current edition of ASHRAE/IES 90.1.
- Complies with the Federal Energy Conservation Standards effective April 16, 2015, in accordance with the Energy Policy and Conservation Act (EPCA), as amended.

Design-Certified by CSA International

- Certified at 300 psi test pressure and 150 psi working pressure.
- Listed according to ANSI Z21.10.1-CSA 4.1 standards governing storage tank-type gas water heaters.

CSA Certified and ASME Rated T&P Relief Valve

6-Year Limited Tank and 2-Year Limited Parts Warranty

- For complete information, consult written warranty or go to hotwater.com.



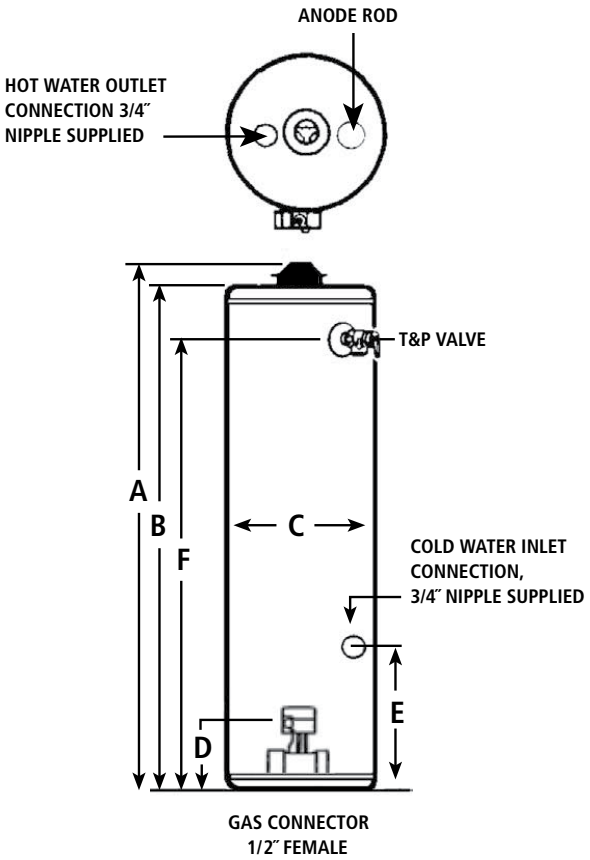

Model Number	Nominal Capacity	Rated Storage Volume	First Hour Rating (Gallons)	UEF	Btu Input Per Hour Natural Gas	Btu Input Per Hour Propane	Recovery @ 90°F Rise Gallon Per Hour	Vent Outlet
FMDV-30	30	29	60	0.61	30,000	29,000	31	3
FMDV-40	40	38	57	0.59	32,000	29,000	33	3
FMDV-50	50	47	67	0.56	40,000	37,000	39	3

Model Number	Dimensions in Inches						Approx. Shipping Weight (lbs)
	A	B	C	D	E	F	
FMDV-30	61	58	18	13	14-1/4	52-1/2	129
FMDV-40	61-3/4	58-3/4	20	13	14-1/4	52-1/4	153
FMDV-50	60	57	22	13	14-1/4	50	168

All models ship from the factory for use with natural gas, a complete propane burner is supplied for converting to propane gas.

No option available for top T&P.

Water connections-3/4" on all models.

All models are certified for installation from sea level to 5,400 ft. elevation.

RESIDENTIAL GAS

PROLINE® ULTRA-LOW NOx



The Electronic Gas Control Incorporates an LED Status Indicator that Monitors System Operation and Service Diagnostics

High UEFs

- Eco-Friendly non-CFC foam insulation, external heat traps and specially designed combustion chamber combine to produce a high UEF for maximum savings on operating costs.

Green Choice® Gas Burner

- Enhanced Ultra-Low NOx burner complies with SCAQMD Rule 1121 and other air quality management districts with similar requirements for NOx emissions of less than 10 ng/J.

DynaClean™ Diffuser Dip Tube

CoreGard™ Anode Rod

Push-Button Piezo Ignitor

Heat Trap Nipples

Blue Diamond® Glass Coating

Enhanced-Flow Brass Drain Valve

Code Compliance

- Meets UBC, CEC and HUD National Codes.
- Meets the thermal efficiency and standby loss requirements of the U.S. Department of Energy and current edition of ASHRAE/IES 90.1.
- Complies with the Federal Energy Conservation Standards effective April 16, 2015, in accordance with the Energy Policy and Conservation Act (EPCA), as amended.

CSA Certified And ASME Rated T&P Valve.

Design-Certified by CSA International

- Certified at 300 psi test pressure and 150 psi working pressure. Listed according to ANSI Z21.10.1-CSA 4.1 standards governing storage tank-type gas water heaters.

6-Year Limited Tank and Parts Warranty

- For complete information, consult written warranty or go to hotwater.com.

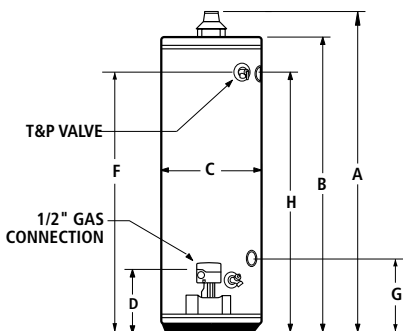
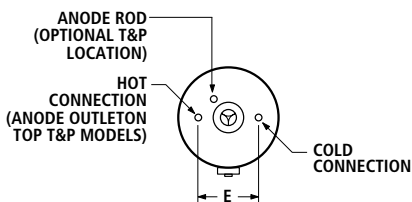

Maximum Hydrostatic Working Pressure: 150 PSI

Model Number	Nominal Capacity	Rated Storage Volume	First Hour Rating (Gallons)	UEF	BTU Input Natural Gas	Recovery @ 90°F Rise Gallon Per Hour	Approx. Shipping Weight (lbs)
Tall Models							
GUC-30	30	29	62	0.59	33,000	34	126
GUC-40	40	38	72	0.55	40,000	41	125
GUR-40	40	38	81	0.64	40,000	41	125
GUC-50	50	48	84	0.61	40,000	42	148
GUR-50	50	48	84	0.64	40,000	42	148
GURT-50L*	50	48	91	0.60	50,000	51	177
Short Models							
GURL-40	40	38	72	0.57	40,000	41	138

Model Number	Dimensions in Inches								Draft Hood
	A	B	C	D	E	F	G*	H*	
Tall Models									
GUC-30	61-3/4	58	16	12	8	51-3/4	N/A	N/A	3 or 4
GUC-40	62	58-1/4	18	12	8	52	N/A	N/A	3 or 4
GUR-40	62	58-1/4	20	12	8	52	N/A	N/A	3 or 4
GUC-50	60-3/4	57-1/4	20	12	8	50-1/2	N/A	N/A	3 or 4
GUR-50	60-3/4	57-1/4	22	12	8	50-1/2	N/A	N/A	3 or 4
GURT-50L*	61	57-1/2	22	12-1/4	8	50-1/2	12-1/4	50-1/2	4
Short Models									
GURL-40	51-1/2	47-3/4	22	12	8	41-1/4	N/A	N/A	3 or 4

All models may be ordered from the factory with top T&P.

*Side loop connections are standard on model (GURT-50L).

*Most models approved for installation from sea level to 7,700 ft. elevation (except on GURT-50L which is approved to 5,400 ft.).

For 10-year tank and 10-year parts limited warranty, change "G" to "X" in model number (example: XUR-40).

PROLINE® ULTRA-LOW NOx DIRECT VENT



Flammable Vapor Resistant/Direct Vent Sealed Combustion System

Durable, Ultra-Low NOx Burner Construction

Non-CFC Foam Insulation

- The tank is surrounded by a thick coat of non-CFC polyurethane foam to trap heat inside the tank, saving energy.

3/4" Top Water Connections and Side Space Heating Connections

1/2" Gas Connection

Coregard™ Anode Rod

Blue Diamond® Glass Coating

Enhanced-Flow Brass Drain Valve

Green Choice® Gas Burner

- Complies with SCAQMD Rule 1121 and other air quality management districts with similar requirements for NOx emissions of less than 10 ng/J.

Code Compliance

- Meets UBC, CEC and HUD National Codes.
- Meets the thermal efficiency and standby loss requirements of the U.S. Department of Energy and current edition of ASHRAE/IES 90.1.
- Complies with the Federal Energy Conservation Standards effective April 16, 2015, in accordance with the Energy Policy and Conservation Act (EPCA), as amended.

CSA Certified And ASME Rated T&P Valve.

Design-Listed by CSA International

- Certified at 300 psi test pressure and 150 psi working pressure.
- Listed according to ANSI Z21.10-1- CSA 4.1 standards governing storage tank-type gas water heaters.

CSA Certified and ASME Rated T&P Relief Valve

6-Year Limited Tank and Parts Warranty

- For complete information, consult written warranty or go to hotwater.com.



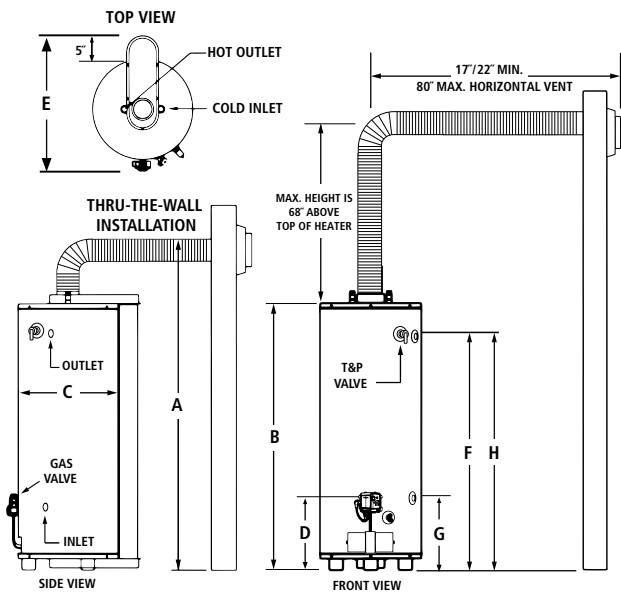

Model Number	Nominal Capacity	Rated Storage Volume	First Hour Rating (Gallons)	UEF	Recovery 90°F Rise Gallon Per Hour	BTU Input Per Hour
GDNL-40L-100	40	28	52	0.60	39	36,000
GDNT-50L-100	50	48	76	0.65	41	38,000

Model Number	Concentric Vent Connection	Dimensions in Inches				Approx. Shipping Weight (lbs)
		A	B	C	D	
GDNL-40L-100	3 or 5	65-1/4	50-1/2	22	13-1/2	179
GDNT-50L-100	3 or 5	73-1/2	58-1/2	22	13-1/2	193

Model Number	Dimensions in Inches			
	E	F	G	H
GDNL-40L-100	30	43-7/8	15	45
GDNT-50L-100	30	52-1/4	15	53

No option available for top T&P valve.

All models have 3/4" top water connections and comes standard with side loop fittings.

All models certified from sea level to 7,700 ft. elevation.

RESIDENTIAL GAS

PROLINE® ULTRA-LOW NO_x HIGH CAPACITY



Fully Automatic Controls with Safety Shutoff

Heavy Gauge Steel Jacket

Blue Diamond® Glass Coating

Foam Insulation

Ultra-Low NO_x Emissions

- Complies with SCAQMD Rule 1146.2 and other Air Quality Management Districts with similar requirements of 14 ng/J or 20 ppm.

Easy-To-Install

- Completely factory-assembled. Only gas, water and vent connections need to be made. All connections are located in front and top of heaters for ease-of-installation and service.

Coregard™ Anode Rod

- Our anode rods have a stainless steel core that extends the life of the anode rod allowing superior tank protection far longer than standard anode rods.

Maximum Working Pressure

- 150 psi.

Maximum Gas Inlet Pressure

- 14" W.C.

Code Compliance

- The Ultra-Low NO_x atmospheric vent residential gas water heater meets the thermal efficiency and standby loss requirements of the U. S. Department of Energy and Current Edition ASHRAE/IES 90.1.

6-Year Limited Tank and Parts Warranty

- For complete information, consult written warranty or go to hotwater.com.

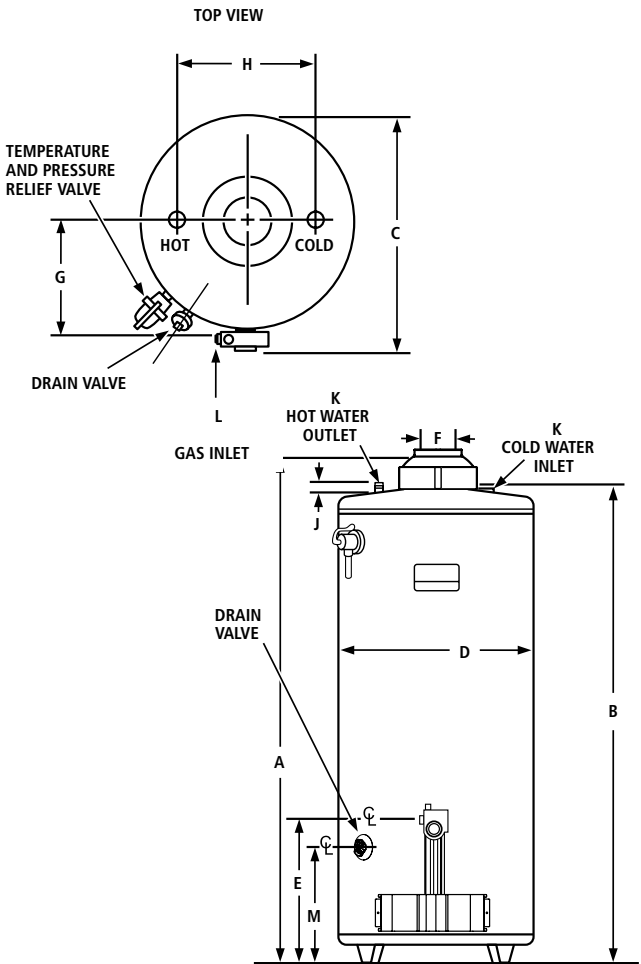

Model Number	Nominal Capacity	Rated Storage Volume	First Hour Rating (Gallons)	UEF	Recovery @ 90°F Rise Gallon Per Hour	BTU Input Per Hour
† GCN-75	74	71	102	0.64	81	75,100
GCN-100	98	95	120	0.58	82	75,100

Model Number	Dimensions in Inches			Approx. Shipping Weight
	Height to Top of Draft Hood	Depth	Diameter	
GCN-75	62-1/16	29-1/2	25-1/4	285 lbs
GCN-100	70-1/2	30-15/16	27-3/4	350 lbs

*Recover rating based on 81% thermal efficiency.

**Recover rating based on 80% thermal efficiency.

†The GCN-75 comes standard with side loop fittings for use with hydronic heating applications.

RESIDENTIAL ELECTRIC

VOLTEX[®] HYBRID ELECTRIC HEAT PUMP



Increased Energy Efficiency

- Reduce water heating costs up to 71% compared to a standard electric water heater.
- Up to a 3.42 Uniform Energy Factor (UEF) Rating conserves energy and meets ENERGY STAR[®] qualifications.

Dual Voltage Capable

- 208/240 VAC 60Hz capable for use in almost any residential installation.

Choice of Operating Modes

- Select from Efficiency, Hybrid or Electric modes to match heating requirements to environmental conditions and hot water demand. Hybrid mode automatically adjusts between compressor and element, depending upon heat requirements.
- Vacation mode reduces operating costs and provides freeze protection during extended absence.

Backup Electric Elements

- Long-lasting 4500W backup heating elements help heat water according to environmental conditions, demand, and the chosen operating mode.

Dry Fire Protection

- Control system checks to ensure the tank is full of water during start up to prevent dry firing the heating elements.

Electronic User Interface

- User-friendly electronic interface allows easy control of temperature setting, operating mode, and communicates diagnostics.
- Advanced diagnostics convey error messages for service purposes. The last four error messages are saved in the control system memory.

Other Features

- Ideal for basements or garage installations; the compressor transfers heat to the water while dehumidifying and cooling the ambient air.
- Washable air filter is easily removed for routine cleaning.
- Accessory Inlet/Outlet Duct Kit (Part number 100234320)

10-Year Limited Warranty

- For complete information, consult written warranty or go to hotwater.com.

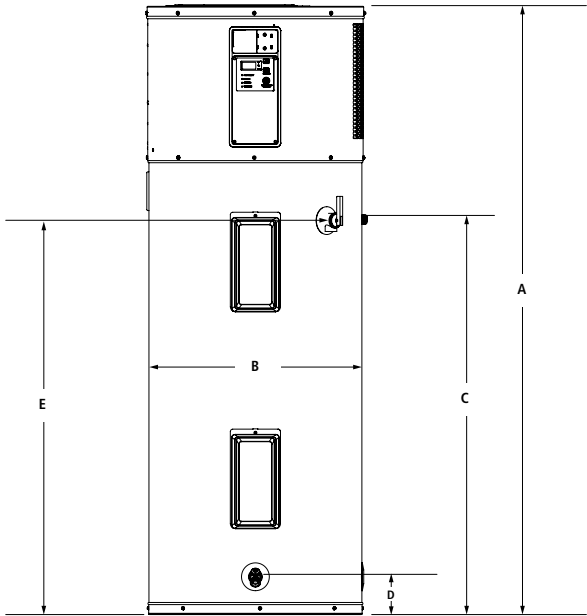

Model Number	Nominal Capacity	Rated Storage Volume	UEF	First Hour Rating (Gallons)	Approx. Shipping Weight (lbs)	Warranty Term
HPTU-50N	50	46	3.42	66	196	10
HPTU-66N	66	67	3.00	79	289	10
HPTU-80N	80	82	2.73	84	307	10

Model Number	Dimensions in Inches				
	A	B	C	D	E
HPTU-50N	63	22	40-5/8	3-3/4	40-1/2
HPTU-66N	61	27	38	4	38
HPTU-80N	69	27	46	4	46

Requires 30 amp breaker.
 Top T&P option not available on this model.

VOLTEX® HYBRID ELECTRIC HEAT PUMP



Increased Energy Efficiency

- Reduce water heating costs up to 71% compared to a standard electric water heater.
- Up to a 3.42 Uniform Energy Factor (UEF) Rating conserves energy and meets ENERGY STAR® qualifications.

Dual Voltage Capable

- 208/240 VAC 60Hz capable for use in almost any residential installation.

Choice of Operating Modes

- Select from Efficiency, Hybrid or Electric modes to match heating requirements to environmental conditions and hot water demand. Hybrid mode automatically adjusts between compressor and element, depending upon heat requirements.
- Vacation mode reduces operating costs and provides freeze protection during extended absence.

Backup Electric Elements

- Long-lasting 4500W backup heating elements help heat water according to environmental conditions, demand, and the chosen operating mode.

Dry Fire Protection

- Control system checks to ensure the tank is full of water during start up to prevent dry firing the heating elements.

Electronic User Interface

- User-friendly electronic interface allows easy control of temperature setting, operating mode, and communicates diagnostics.
- Advanced diagnostics convey error messages for service purposes. The last four error messages are saved in the control system memory.

Other Features

- Ideal for basements or garage installations; the compressor transfers heat to the water while dehumidifying and cooling the ambient air.
- Washable air filter is easily removed for routine cleaning.
- Accessory Inlet/Outlet Duct Kit (Part number 100234320)

6-Year Limited Warranty

- For complete information, consult written warranty or go to hotwater.com.

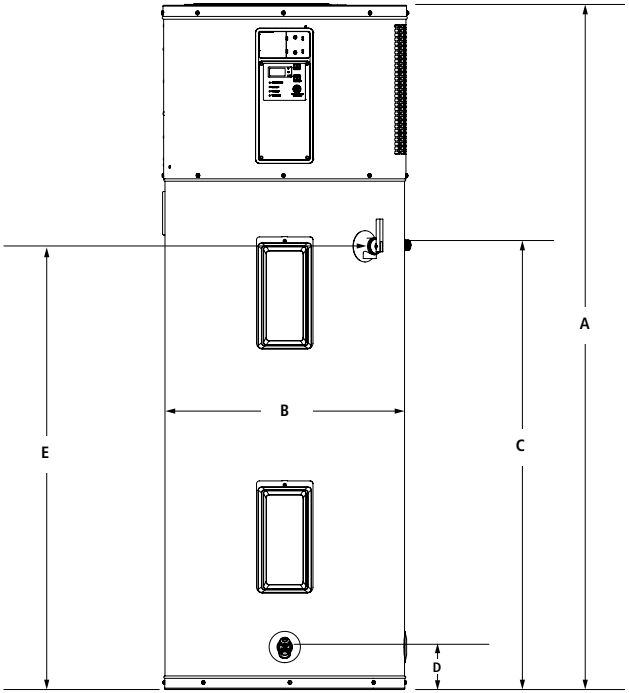

Model Number	Nominal Capacity	Rated Storage Volume	UEF	First Hour Rating (Gallons)	Approx. Shipping Weight (lbs)	Warranty Term
FPTU-50	50	46	3.42	66	196	6
FPTU-66	66	67	3.00	79	289	6
FPTU-80	80	82	2.73	84	307	6

Model Number	Dimensions in Inches				
	A	B	C	D	E
FPTU-50	63	22	40-5/8	3-3/4	40-1/2
FPTU-66	61	27	38	4	38
FPTU-80	69	27	46	4	46

Requires 30 amp breaker.
 Top T&P option not available on this model.

RESIDENTIAL ELECTRIC

PROLINE® XE ELECTRONIC DISPLAY



Electronic User Interface

- Touchscreen display.
- Multiple operating modes help save money.
 - Energy Saver and vacation modes available.
- Diagnostic feedback.
- Dry fire protection.

Enhanced Heating Elements

- Dual 5500 watt elements for the fastest recovery and reliable operation.
- Incoloy stainless steel elements last longer than standard copper elements.

Enhanced-Flow Brass Drain Valve

Code Compliance

- Meets UBC, CEC and HUD National Codes.
- Meets the thermal efficiency and standby loss requirements of the U.S. Department of Energy and current edition of ASHRAE/IES 90.1.
- Complies with the Federal Energy Conservation Standards effective April 16, 2015, in accordance with the Energy Policy and Conservation Act (EPCA), as amended.

Approved for Manufactured Housing

- All residential electric water heaters are compliant with HUD standards for mobile homes/ manufactured housing.

Design-Listed by Underwriters Laboratories

- Certified at 300 psi test pressure and 150 psi working pressure.
- Listed according to UL 174 standards governing storage tank-type electric water heaters.

10-Year Limited Tank and Parts Warranty

- For complete information, consult written warranty or go to hotwater.com.

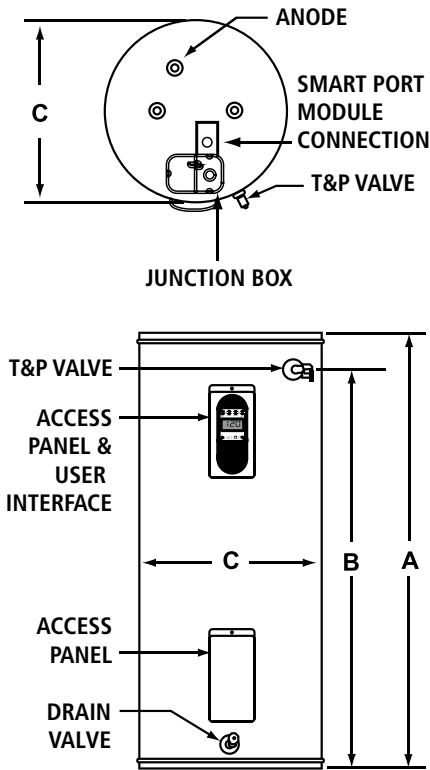

Model Number	Nominal Capacity	Rated Storage Volume	First Hour Rating (Gallons)	UEF	Recovery @ 90°F Rise Gallon Per Hour	Approx. Shipping Weight (lbs)
Tall Models						
PXNT-40	40	36	65	0.92	25	118
PXNT-50	50	45	81	0.95	25	134
PXNT-55	55	55	89	0.95	25	145
Short Models						
PXNS-40	40	37	60	0.93	25	109
PXNS-50	50	46	75	0.95	25	161

Model Number	Element Wattage 240V		Dimensions in Inches		
	Standard	Maximum	A	B	C
Tall Models					
PXNT-40	5500	6000	61-1/4	53-1/4	20
PXNT-50	5500	6000	60-1/2	51-1/4	22
PXNT-55	5500	6000	56-1/2	48-1/2	24
Short Models					
PXNS-40	5500	6000	49 3/4	40-3/4	20-1/2
PXNS-50	5500	6000	49-1/4	40-1/4	23

Only available for 240V or 208V applications.
 Equipped as dual element only; no single element configurations available.
 Top T&P option not available on these models.
 3/4" water connections on 8" center.

RESIDENTIAL ELECTRIC

PROLINE® MASTER STANDARD



Commercial-Grade Heating Elements

- Dual 4500 watt elements for the fastest recovery and reliable operation.
- Long-lasting dual stainless steel elements last longer than standard copper elements.

High Uniform Energy Factors (UEFs)

DynaClean™ Diffuser Dip Tube

CoreGard™ Anode Rod

- ProLine® Master products have increased anode protection with either longer or multiple anodes, depending on model.

Code Compliance

- Meets UBC, CEC and HUD National Codes.
- Meets the thermal efficiency and standby loss requirements of the U.S. Department of Energy and current edition of ASHRAE/IES 90.1.
- Complies with the Federal Energy Conservation Standards effective April 16, 2015, in accordance with the Energy Policy and Conservation Act (EPCA), as amended.

Approved for Manufactured Housing

- All residential electric water heaters are compliant with HUD standards for mobile homes/ manufactured housing.

Design-Listed by Underwriters Laboratories

- Certified at 300 psi test pressure and 150 psi working pressure.
- Listed according to UL 174 standards governing storage tank-type electric water heaters.

8-Year Limited Tank and Parts Warranty

- For complete information, consult written warranty or go to hotwater.com.

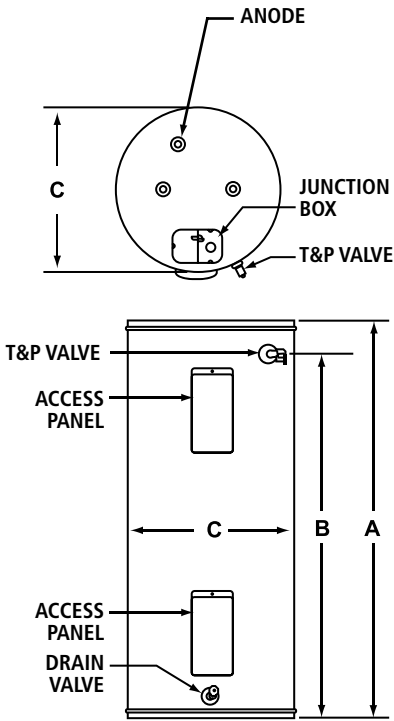

Model Number	Nominal Capacity	Rated Storage Volume	First Hour Rating (Gallons)	UEF	Recovery @ 90°F Rise Gallon Per Hour
Tall Models					
HNT-40	40	36	53	0.92	21
HNT-50	50	46	62	0.93	21
HNT-55	55	55	72	0.93	21
Short Models					
HNS-40	40	37	55	0.92	21
HNS-50	50	46	57	0.92	21

Model Number	Element Wattage 240V		Dimensions in Inches			Approx. Shipping Weight (lbs)
	Standard	Maximum	A	B	C	
Tall Models						
HNT-40	4500	6000	61-1/2	53-1/4	18	118
HNT-50	4500	6000	60-1/2	51-1/4	20-1/2	125
HNT-55	4500	6000	56-1/2	48-1/2	24	145
Short Models						
HNS-40	4500	6000	49-3/4	40-3/4	20-1/2	109
HNS-50	4500	6000	49-1/4	40-3/8	23	161

Male 3/4" water connections on 8" center.

RESIDENTIAL ELECTRIC

PROLINE® STANDARD



Enhanced Heating Elements

- Dual 4500 watt elements for the fastest recovery and reliable operation.
- Incoloy stainless steel lower element lasts longer than standard copper elements.

High Uniform Energy Factors (UEFs)

DynaClean™ Diffuser Dip Tube

CoreGard™ Anode Rod

Code Compliance

- Meets UBC, CEC and HUD National Codes.
- Meets the thermal efficiency and standby loss requirements of the U.S. Department of Energy and current edition of ASHRAE/IES 90.1.
- Complies with the Federal Energy Conservation Standards effective April 16, 2015, in accordance with the Energy Policy and Conservation Act (EPCA), as amended.

Approved for Manufactured Housing

- All residential electric water heaters are compliant with HUD standards for mobile homes/ manufactured housing.

Design-Listed by Underwriters Laboratories

- Certified at 300 psi test pressure and 150 psi working pressure.
- Listed according to UL 174 standards governing storage tank-type electric water heaters.

6-Year Limited Tank and Parts Warranty

- For complete information, consult written warranty or go to hotwater.com.

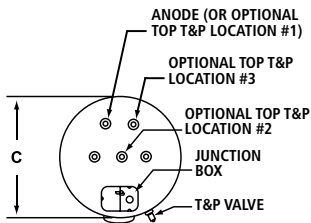
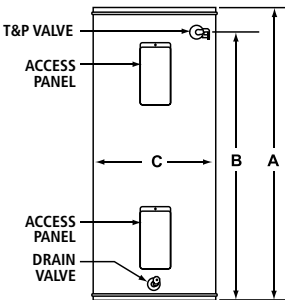

Model Number	Nominal Capacity	Rated Storage Volume	First Hour Rating (Gallons)	UEF	Recovery @ 90°F Rise Gallon Per Hour	Element Wattage 240V	
						Standard	Maximum
Tall Models							
ENT-30†	30	27	48	0.89	21	4500	6000
ENT-40†	40	36	53	0.92	21	4500	6000
ENT-50†	50	46	62	0.93	21	4500	6000
ENT-55†	55	55	72	0.93	21	4500	6000
Short Models							
ENSB-30*	30	27	50	0.90	21	4500	6000
ENS-30†	30	27	47	0.89	21	4500	6000
ENS-40†	40	37	55	0.92	21	4500	6000
ENS-50†	50	46	57	0.92	21	4500	6000
Lowboy Top Connect Models							
ENL-20	19.9	19	N/A	N/A	21	4500	6000
ENLB-30*†	28	26	46	0.89	21	4500	6000
ENL-30†	28	26	46	0.90	21	4500	6000
ENL-36†	36	33	51	0.92	21	4500	6000
ENL-40†	38	35	49	0.89	21	4500	6000
ENLB-40*†	38	35	47	0.93	21	4500	6000
ENLB-50*†	48	44	60	0.93	21	4500	6000
ENL-50†	51	48	54	0.92	21	4500	6000

Model Number	Dimensions in Inches			Approx. Shipping Weight (lbs)
	A	B	C	
Tall Models				
ENT-30†	46-1/2	39-1/2	19	95
ENT-40†	61-1/4	53-1/4	18	118
ENT-50†	60-1/2	51-1/4	20-1/2	125
ENT-55†	56-1/2	48-1/2	24	145
Short Models				
ENSB-30*	39	30-1/2	20	95
ENS-30†	39-3/4	30-1/2	22	94
ENS-40†	49-3/4	40-3/4	20-1/2	109
ENS-50†	49-1/4	40-3/8	23	161
Lowboy Top Connect Models				
ENL-20	30	21-1/4	20	65
ENLB-30*†	30	21-3/4	20	90
ENL-30†	30	21-3/4	22	115
ENL-36†	32	24	24	118
ENL-40†	33 1/2	24	26	118
ENLB-40*†	32	24	23	118
ENLB-50*†	34	25	26-1/2	172
ENL-50†	36	25	26-1/2	172

* Models ship with supplied insulation blanket.

† For 10-year tank and 10-year parts warranty, change "E" to "P" in the model number (example: ENT-30 becomes PNT).

Top T&P is not available on the 10 year lowboy models.

3/4" water connections on 8" center.

ENL-20 is a single element configuration only



Approved for Manufactured Housing

- All residential electric water heaters are compliant with HUD standards for mobile homes/ manufactured housing.

Side Water Connections

- For ease of installation in mobile home applications.

CoreGard™ Anode Rod

- Our anode rods have a stainless steel core that extends the life of the anode rod allowing superior tank protection far longer than standard anode rods.

Long-Lasting Heating Elements

- Screw-in, direct immersion, 3500W/240V or 3000W/120V heating elements for maximum efficiency.

Blue Diamond® Glass Coating

Enhanced-Flow Brass Drain Valve

- Our residential water heaters have a solid brass, tamper resistant, enhanced-flow, ball type, drain valve.
- Uses a standard female hose fitting that allows for fast and easy draining during maintenance.

CSA Certified and ASME Rated T&P Relief Valve

Code Compliance

- Meets UBC, CEC and HUD National Codes.
- Meets the thermal efficiency and standby loss requirements of the U.S. Department of Energy and current edition of ASHRAE/IES 90.1.
- Complies with the Federal Energy Conservation Standards effective April 16, 2015, in accordance with the Energy Policy and Conservation Act (EPCA), as amended.

Design-Listed by Underwriters Laboratories

- Certified at 300 psi test pressure and 150 psi working pressure.
- Listed according to UL 174 standards governing storage tank-type electric water heaters.

6-Year Limited Tank and Parts Warranty

- For complete information, consult written warranty or go to hotwater.com.

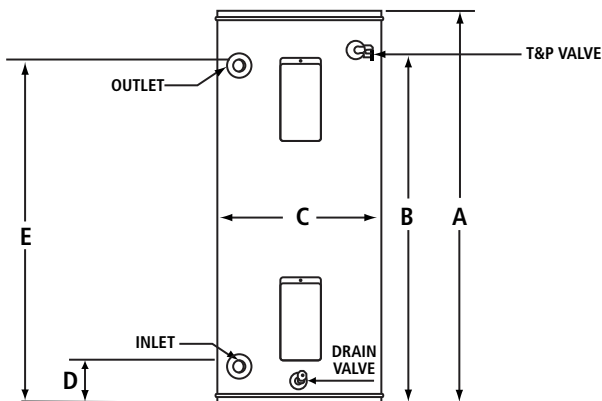
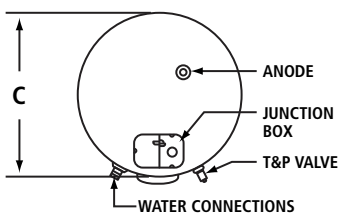

Model Number	Nominal Capacity	Rated Storage Volume	UEF	First Hour Rating (Gallons)	Recovery @ 90°F Rise Gallon Per Hour	Voltage
MHE6-30H-030D	30	27	0.90	50	14	120
MHE6-30H-035D	30	27	0.90	50	16	240
MHE6-40R-030D	40	36	0.95	54	14	120
MHE6-40R-035D	40	36	0.95	54	16	240
MHE6-30L-030D*	28	26	0.90	47	14	120
MHE6-30L-035D*	28	26	0.90	47	16	240

Model Number	Wattage		Dimensions in Inches		Approx. Shipping Weight (lbs)
	Upper Element	Lower Element	Height to Top of Heater	Diameter	
MHE6-30H-030D	3000	3000	46-3/4	19	98
MHE6-30H-035D	3500	3500	46-3/4	19	98
MHE6-40R-030D	3000	3000	50	22	109
MHE6-40R-035D	3500	3500	50	22	109
MHE6-30L-030D*	3000	3000	30	22	96
MHE6-30L-035D*	3500	3500	30	22	96

* Models ship with supplied insulation blanket.

MHE6 models may have limited element options due to element size or other restrictions. Available with side T&P only.

3/4" water connections.

RESIDENTIAL ELECTRIC

PROLINE® SPECIALTY ELECTRIC



LOWBOY



TABLE TOP



COMPACT



POINT-OF-USE

Approved For Manufactured Housing

- All residential electric water heaters are compliant with HUD standards for mobile homes/manufactured housing.

Table-Top

- Features a convenient flat porcelain surface at 36" height, providing extra "counter space" wherever installed. All plumbing and electrical connections are made through the back of the water heater. This heater is equipped with a PEX cross-linked polymer dip tube.

Point-of-Use

- Designed for low-demand, such as office lavatories or buildings with remote restrooms.

Compact

- Side-mounted plumbing and electrical connections (optional top-mounted water connections for field conversion). Designed for installation under a counter, in a crawl space or in other tight spaces.

Code Compliance

- Meets UBC, CEC and HUD National Codes.
- Meets the thermal efficiency and standby loss requirements of the U.S. Department of Energy and current edition of ASHRAE/IES 90.1.
- Complies with the Federal Energy Conservation Standards effective April 16, 2015, in accordance with the Energy Policy and Conservation Act (EPCA), as amended.

Design-Listed By Underwriters Laboratories

- Certified at 300 psi test pressure and 150 psi working pressure.
- Listed according to UL 174 standards governing storage tank-type electric water heaters.

6-Year Limited Tank And Parts Warranty

- For complete information, consult written warranty or go to hotwater.com.

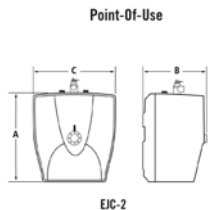
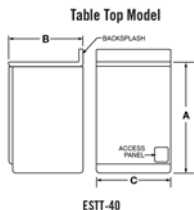
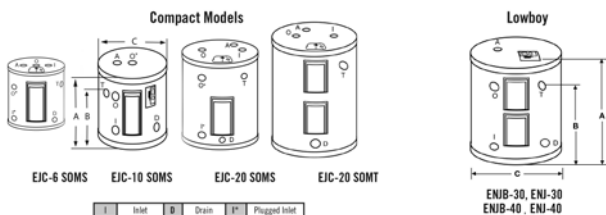

Model Number	Nominal Capacity	Rated Storage Volume	First Hour Rating (Gallons)	UEF	Element Wattage	
					Standard	Maximum
Compact Models					120V	240V
EJC-6	6	6	N/A	N/A	1650	3000
EJC-10	10	9	N/A	N/A	1650	6000
EJCS-20	19	17	N/A	N/A	2500	6000
EJCT-20	19.9	18	N/A	N/A	2500	6000
Lowboy Side-Connect Model					240V	
ENJB-30*	28	26	47	0.90	4500	6000
ENJ-30	28	26	43	0.91	4500	6000
ENJB-40*	38	35	57	0.94	4500	6000
ENJ-40	38	35	54	0.93	4500	6000
Table Top Model					240V	
ESTT-40	38	35	55	0.90	4500	5500
Point-Of-Use-Models					120V	
EJC-2	2.5	2	N/A	N/A	1500 @ 120V	

Model Number	Recovery @ 90°F Rise Gallons Per Hour	Dimensions in Inches			Approx. Shipping Weight (lbs)
		A	B	C	
Compact Models					
EJC-6	8	15-1/4	10-3/4	14-1/4	35
EJC-10	8	18-1/4	12-1/4	16	41
EJCS-20	11	24-3/4	18-5/8	18	68
EJCT-20	11	31-5/8	25-3/4	16	68
Lowboy Side-Connect Model					
ENJB-30*	21	30	21-3/4	22	101
ENJ-30	21	31-1/4	21-3/4	24	115
ENJB-40*	21	31-3/4	24	24	118
ENJ-40	21	33-1/2	24	26	118
Table Top Model					
ESTT-40	21	36	24	25	150
Point-Of-Use-Models					
EJC-2	7	13-3/4	11	13-3/4	20

*Models ship with supplied insulation blanket.

RESIDENTIAL

PUMP TANKS



Multiple Head Construction Adds Structural Strength and More Capacity within the Same Diameters

- Interior powder coating is permanently bonded to the tank shell for ultimate protection on the water side of the tank.
- Butyl rubber parabolic diaphragm.
- Positive lock retention system controls compression in the diaphragm connection, eliminating air loss or water leaks in tank.
- Electrostatically applied powder-coated exterior for maximum sunlight (UV) resistance with zinc phosphate undercoat for highest corrosion resistance.
- Corrosion-resistant metal air valve.
- Rust Guard No-weld steel base
- 5-year limited warranty.

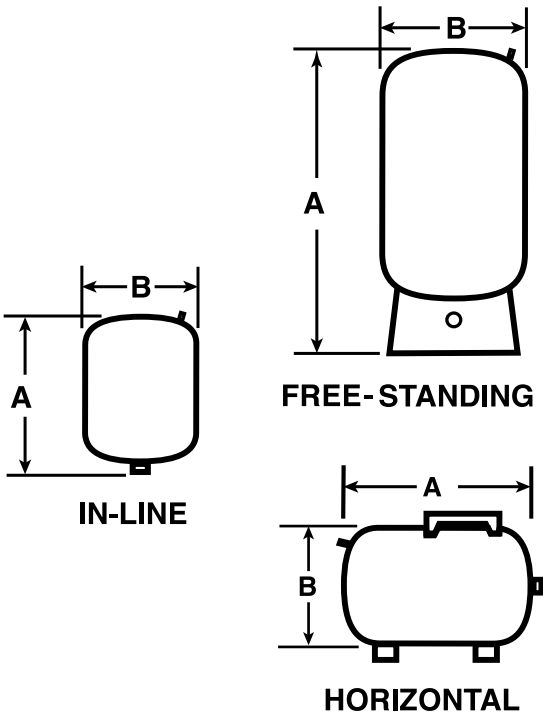

Model Number	Volume (Gallons)	Connecting NPT Size	Dimensions in Inches			Weight (lbs.)
			Overall Height -A	To Center of Water Inlet	Diameter-B	
PMI (Inline) and PM (Free-Standing) Series						
PMI-2	2.0	3/4 (M)	10-3/16	-	8-1/4	5
PMI-5	4.6	3/4 (M)	14-3/4	-	11	9
PMI-7	7.3	3/4 (M)	21-1/16	-	11	14
PMI-14	13.9	1 (M)	21-1/16	2	15-3/8	24
PM-14	13.9	1 (F)	24-15/16	2	15-3/8	24
PM-20	19.9	1 (F)	32-3/8	2	15-3/8	34
PM-26	25.9	1 (F)	39-9/16	2	15-3/8	43
PM-32	31.8	1 (F)	47-1/4	2	15-3/8	52
PM-45	45.2	1-1/4 (F)	36-9/16	2-1/2	22	65
PM-65	65.1	1-1/4 (F)	48-5/8	2-1/2	22	90
PM-85	84.9	1-1/4 (F)	60-11/16	2-1/2	22	114
PM-86	83.5	1-1/4 (F)	46	2-1/2	26	116
PM-119	115.9	1-1/4 (F)	61-5/16	2-1/2	26	161
Horizontal Series			Length-A		Diameter-B	
PMH-7	7.3	3/4 (M)	12-7/8	-	11	16
PMH-14	13.9	1 (M)	18-1/4	-	15-3/8	25
PMH-20	19.9	1 (M)	18-1/4	-	15-3/8	36

NOTE: M-Male connection
 F-Female connection
 All models 38 psi pre-charge

RESIDENTIAL

EXPANSION TANKS



Interior Powder Coating is Permanently Bonded to the Tank Shell for Ultimate Protection on the Inside of the Tank

Butyl Rubber Parabolic Diaphragm

Positive Lock Retention System Controls Compression in the Diaphragm Connection, Eliminating Air Loss or Water Leaks in Tank

Projection Welded Air Valve

5-Year Limited Warranty on PMC Expansion Tanks

1-Year Limited Warranty on Hydronic Expansion Tanks



When used in potable applications

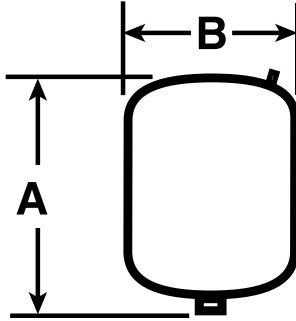

Model Number	Maximum (psig) Working Pressure	Tank Volume (Gallons)	Maximum Accepted Volume (Gallons)		
			20 psi	40 psi	60 psi
PMC-Series (Potable Expansion Tanks - 5-Year Limited Warranty)					
PMC-10	150	9.25	7.80	6.55	5.25
PMET-Series (Hydronic Expansion Tanks - 1-Year Limited Warranty)					
PMET-2	100	1.96	1.53	N/A	N/A
PMET-5	100	4.55	3.75	N/A	N/A
PMET-7	100	7.30	4.60	N/A	N/A
PMET-14	100	14.6	10.5	N/A	N/A

Model Number	Connection NPT Size	Dimensions in Inches		Weight (lbs)
		Overall Height - A	Diameter - B	
PMC-Series (Potable Expansion Tanks - 5-Year Limited Warranty)				
PMC-10	3/4	15-1/2	15-3/8	18
PMET-Series (Hydronic Expansion Tanks - 1-Year Limited Warranty)				
PMET-2	1/2	10-3/16	8-1/4	5
PMET-5	1/2	14-3/4	11	9
PMET-7	1/2	21-1/16	11	14
PMET-14	1/2	23-1/2	15-3/8	25

All PMC models 38 psi pre-charge.
 All PMET models 12 psi pre-charge.

TANKLESS RESIDENTIAL

PROLINE® XE CONDENSING WITH RECIRCULATION PUMP



INDOOR MODEL



OUTDOOR MODEL



ANSI Z21.10.3 • CSA 4.3

Integrated Recirculation Pump

- Simplify installation by eliminating added time and money spend sourcing and installing pump and controls. Integrated front panel controls are easy to view and set.
- 1/2" pipe - 200'
- 3/4" pipe - 500'

Pump Controls

- Included with heater
- Two timer settings
- Adjustable differential settings

ENERGY STAR® Qualified

Ultra-Low NOx Emissions

- Complies with SCAQMD 1146.2 NOx emission requirements of 14 ng/J or 20 PPM

Indoor Models

- Include integrated temperature and pump controls with advanced diagnostics that simplify installation and troubleshooting
- Factory-installed power cord

Outdoor Models

- Includes a wall mount temperature remote controller and advanced diagnostics to simplify troubleshooting

Common Vent Indoor Models Up to 8 Heaters

- Easy-link with up to three 540H condensing tankless heaters to increase flow capacity

Safety Features

- Air-Fuel Ratio (AFR) Sensor.
- Exhaust & Water Temperature Safety Control.
- Overheat Cut-Off Fuse.

Internal Freeze Protection

Warranty

- 15-year limited warranty on heat exchanger in residential applications
- 6-year limited warranty on heat exchanger in commercial applications
- 5-year warranty on all parts

INDOOR MODEL

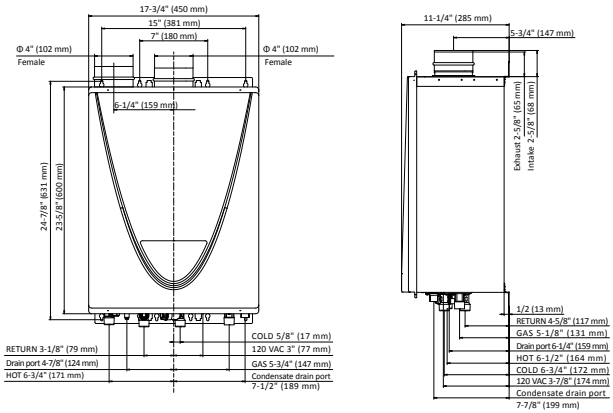

OUTDOOR MODEL

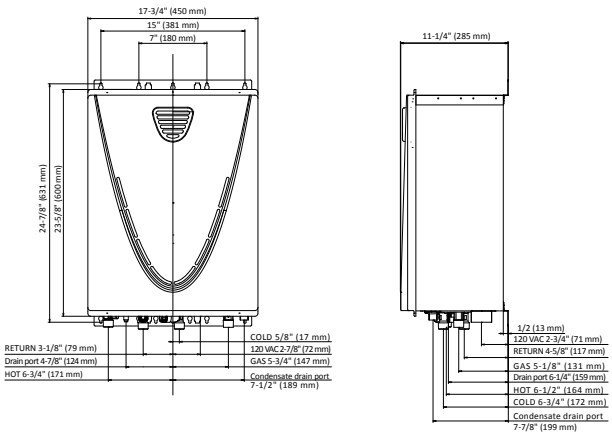

Model Number*	Type	Gas Consumption Input		Inlet Gas Pressure***	
		Minimum** (BTU/H)	Maximum (BTU/H)	Minimum (in. W.C.)	Maximum (in. W.C.)
ATI-540P-N	Natural	15,000	199,000	4.0	10.5

Model Number*	Indoor Model UEF	Outdoor Model UEF	Connections		Sizing Chart (Number of Showers)	
			Water	Gas	Cold Climate†	Warm Climate‡
ATI-540P-N	0.93	0.95	3/4" NPT	3/4" NPT	3	4.5

Model Number*	Clearances (in.)				Approx Shipping Weight (lbs)
	Top	Bottom	Side	Front	
ATI-540P-N	12	12	3	4	71

* For outdoor models, change "ATI" to "ATO". For propane models, change "N" to "P"

** For propane models, minimum is 13,000

*** For propane models, minimum inlet gas pressure is 8.0 in. W.C. and maximum inlet gas pressure is 14.0 in. W.C.

† Cold climate represents 70°F temperature rise

‡ Warm climate represents 50°F temperature rise

TANKLESS RESIDENTIAL

PROLINE® XE CONDENSING HIGH EFFICIENCY



INDOOR MODEL



OUTDOOR MODEL



ANSI Z21.10.3 CSA 4.3

ENERGY STAR® Qualified

Condensing Technology Provides Up to 0.91 UEF

Ultra-Low NOx Emissions

- Complies with SCAQMD 1146.2 NOx emission requirements of 14 ng/J or 20 PPM.

Copper Primary Heat Exchanger

- 25x better heat transfer than stainless steel thus stabilizing outgoing water temperature quicker and reducing pressure drop across the heat exchanger.

Secondary Heat Exchanger

- Marine-Grade 316L stainless steel to protect against corrosion.

Indoor Models

- Include a built-in temperature controller and advanced diagnostics to simplify troubleshooting.
- Include factory-installed power cords

Outdoor Models

- Include a wall mount temperature remote controller and advanced diagnostics to simplify troubleshooting.

Electronic Ignition - No Pilot Light

Safety Features:

- Air-Fuel Ratio (AFR) Sensor.
- Exhaust & Water Temperature Safety Control.
- Overheat Cut-Off Fuse.

Internal Freeze Protection System

Power Vent or Power Direct Vent Design

Warranty

- 15-year limited warranty on heat exchanger in residential applications.
- 6-year limited warranty on heat exchanger in commercial applications.
- 5-year limited warranty on all parts.

TANKLESS RESIDENTIAL & COMMERCIAL PROLINE® XE CONDENSING HIGH EFFICIENCY



INDOOR MODEL



OUTDOOR MODEL



ANSI Z21.10.3

CSA 4.3

ENERGY STAR® Qualified

Condensing Technology Provides Up to 0.95 UEF

Ultra-Low NOx Emissions

- Complies with SCAQMD 1146.2 NOx emission requirements of 14 ng/J or 20 PPM.

Maximum Flow Rates up to 10.0 GPM

Heat Exchanger

- Primary heat exchanger of the ATI/ATO-540 is constructed of a commercial-grade copper that is more resilient to erosion. Copper is 25x better at heat transfer than stainless steel thus stabilizing outgoing water temperature quicker and reducing pressure drop across the heat exchanger.
- Secondary heat exchanger is made of marine-grade 316L stainless steel to protect against corrosion.

Indoor Models

- Include integrated temperature controls and advanced diagnostics to simplify troubleshooting.
- Include factory-installed power cords

Outdoor Models

- Include a wall mount temperature remote controller and advanced diagnostics to simplify troubleshooting.

Common Vent Indoor Models up to 8 Units

540H Can Be Used In Both Residential and Commercial Applications

- Easy-link up to 4 heaters.
- Multi-link up to 20 heaters.

Safety Features

- Air-Fuel Ratio (AFR) Sensor.
- Exhaust & Water Temperature Safety Control.
- Overheat Cut-off Fuse.

Internal Freeze Protection System

Power Vent or Power Direct Vent Design

Warranty

- 15-year limited warranty on heat exchanger in residential applications.
- 6-year limited warranty on heat exchanger in commercial applications.
- 5-year limited warranty on all parts.

INDOOR MODEL

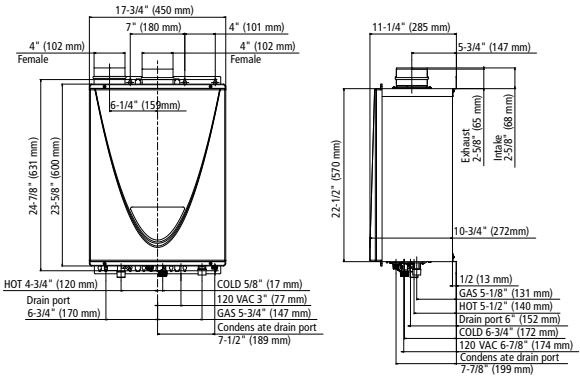

OUTDOOR MODEL

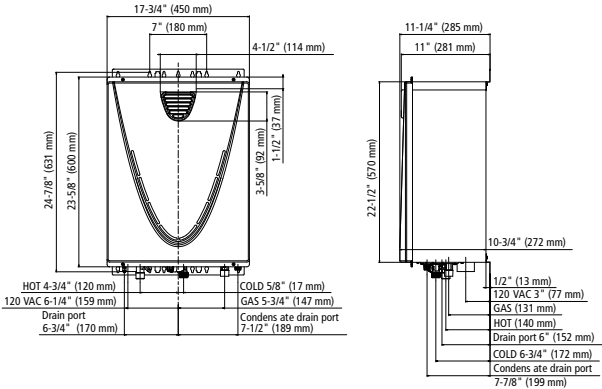

Model Number*	Type	Gas Consumption Input		Inlet Gas Pressure***	
		Minimum** (BTU/H)	Maximum (BTU/H)	Minimum (in. W.C.)	Maximum (in. W.C.)
ATI-240H-N	Natural	15,000	160,000	4.0	10.5
ATI-340H-N	Natural	15,000	180,000	4.0	10.5
ATI-540H-N	Natural	15,000	199,000	4.0	10.5

Model Number*	Indoor Model UEF	Outdoor Model UEF	Connections		Sizing Chart (Number of Showers)	
			Water	Gas	Cold Climate†	Warm Climate‡
ATI-240H-N	0.94	0.95	3/4" NPT	3/4" NPT	2.5	3.5
ATI-340H-N	0.95	0.94	3/4" NPT	3/4" NPT	2.5	4.0
ATI-540H-N	0.93	0.95	3/4" NPT	3/4" NPT	3	4.5

Model Number*	Clearances (in.)				Approx Shipping Weight (lbs)
	Top	Bottom	Side	Front	
ATI-240H-N	12	12	3	4	71
ATI-340H-N	12	12	3	4	71
ATI-540H-N	12	12	3	4	71

*For outdoor models, change "ATI" to "ATO". For propane models, change "N" to "P"

**For propane models, minimum is 13,000

***For propane models, minimum inlet gas pressure is 8.0 in. W.C. and maximum inlet gas pressure is 14.0 in. W.C.

† Cold climate represents 70°F temperature rise

‡ Warm climate represents 50°F temperature rise

TANKLESS RESIDENTIAL

PROLINE® XE

NON-CONDENSING CONCENTRIC VENT



Meets SCAQMD
Rule 1146.2



ANSI Z21.10.3



(510c models only)

Concentric Vent Design

- Power direct vent
- Vertical or horizontal venting up to 43'

Field Convertible from Natural Gas to Propane

Ultra-Low NOx Emissions

- Complies with SCAQMD Rule 1146.2 NOx emission requirements of 14 ng/J or 20 PPM.

Maximum Flow Rates up to 10.0 GPM

Primary Heat Exchanger

- Primary heat exchanger of the ATI-510C is constructed of a commercial-grade copper that is more resilient to erosion. Copper is 25x better at heat transfer than stainless steel thus stabilizing outgoing water temperatures quicker and reducing pressure drop across the heat exchanger.

Indoor Models Only

- Include integrated temperature controls and advanced diagnostics to simplify troubleshooting.
- Include factory-installed power cords

ATI-510C Can be Used in Both Residential and Commercial Applications

- Easy-Link up to 4 units
- Multi-Link up to 20 units

Safety Features

- Air-Fuel Ratio (AFR) Sensor.
- Exhaust & Water Temperature Safety Control.
- Overheat Cut-Off Fuse.

Internal Freeze Protection

Warranty

- 15-year limited warranty on heat exchanger in residential applications.
- 6-year limited warranty on heat exchanger in commercial applications.
- 5-year limited warranty on all parts.

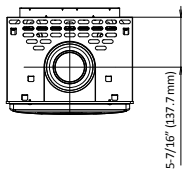

Top view

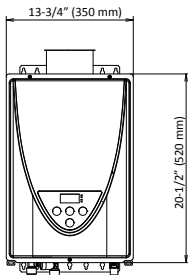

Front view

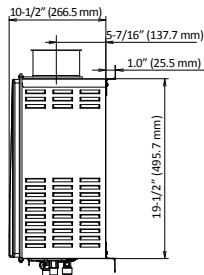

Side view

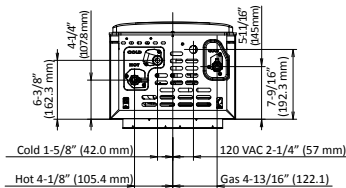

Bottom view

Model Number*	Gas Consumption Input		Inlet Gas Pressure**	
	Minimum (BTU/H)	Maximum (BTU/H)	Minimum (in. W.C.)	Maximum (in. W.C.)
ATI-110C-N	15,000	140,000	4.0	10.5
ATI-310C-N	15,000	190,000	4.0	10.5
ATI-510C-N	15,000	199,000	4.0	10.5

Model Number*	UEF	Connections		Sizing Chart (Number of Showers)	
		Water	Gas	Cold Climate†	Warm Climate‡
ATI-110C-N	0.79	3/4" NPT	3/4" NPT	1.5	2.5
ATI-310C-N	0.82	3/4" NPT	3/4" NPT	2.5	3.5
ATI-510C-N	0.81	3/4" NPT	3/4" NPT	2.5	3.5

Model Number*	Clearances (in.)				Approx Shipping Weight (lbs)
	Top	Bottom	Side	Front	
ATI-110C-N	12	12	3	4	55
ATI-310C-N	12	12	3	4	55
ATI-510C-N	12	12	3	4	55

*Indoor models only. Units are field convertible from natural gas to propane with supplied conversion kit.

**When converted for propane, minimum inlet gas pressure is 8.0 in. W.C. and maximum inlet gas pressure is 14.0 in. W.C.

† Cold climate represents 70°F temperature rise

‡ Warm climate represents 50°F temperature rise

TANKLESS RESIDENTIAL & COMMERCIAL PROLINE® XE NON-CONDENSING



INDOOR MODEL



OUTDOOR MODEL



ANSI Z21.10.3 CSA 4.3

Maximum Flow Rates up to 10.0 GPM

Copper Primary Heat Exchanger

- Primary heat exchanger of the ATI/ATO-510 is constructed of a commercial-grade copper that is more resilient to erosion. Copper is 25x better at heat transfer than stainless steel thus stabilizing outgoing water temperatures quicker and reducing pressure drop across the heat exchanger

Indoor Models

- Includes a wall mount temperature remote controller and advanced diagnostics to simplify troubleshooting
- Includes factory-installed power cord

Outdoor Models

- Includes a wall mount temperature remote controller and advanced diagnostics to simplify troubleshooting

Low NOx Emissions

ATI-510 & ATO-510 Can Be Used In Both Residential and Commercial Applications

- Easy-Link up to 4 units

Safety Features

- Air-Fuel Ratio (AFR) Sensor.
- Exhaust & Water Temperature Safety Control.
- Overheat Cut-Off Fuse.

Internal Freeze Protection

Power Vent or Power Direct Vent Design

Warranty

- 15-year limited warranty on heat exchanger in residential applications.
- 6-year limited warranty on heat exchanger in commercial applications.
- 5-year warranty on all parts.

INDOOR MODEL (DIMENSIONS FOR 310/510 MODELS)

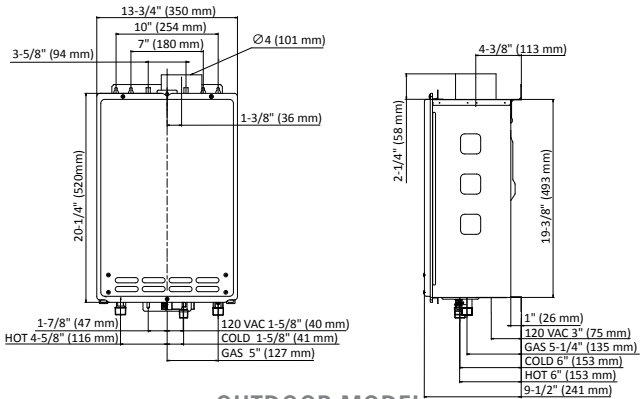

OUTDOOR MODEL

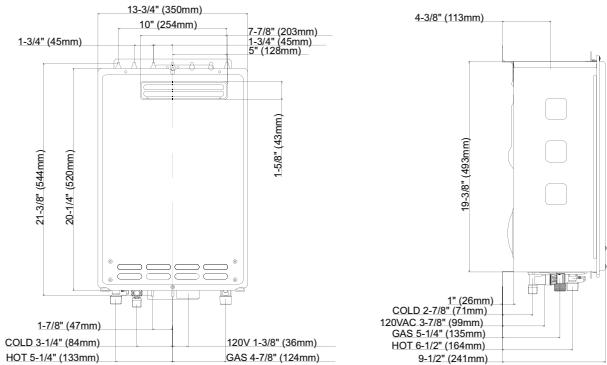

Model Number*	Type	Gas Consumption Input		Inlet Gas Pressure**	
		Minimum** (BTU/H)	Maximum (BTU/H)	Minimum (in. W.C.)	Maximum (in. W.C.)
ATI-110-N	Natural	19,500	140,000	4.0	10.5
ATI-310-N	Natural	11,000	190,000	4.0	10.5
ATI-510-N	Natural	11,000	199,000	4.0	10.5

Model Number*	UEF (Indoor and Outdoor)	Connections		Sizing Chart (Number of Showers)	
		Water	Gas	Cold Climate†	Warm Climate‡
ATI-110-N	0.79	3/4" NPT	3/4" NPT	1.5	2.5
ATI-310-N	0.80	3/4" NPT	3/4" NPT	2.5	3.5
ATI-510-N	0.80	3/4" NPT	3/4" NPT	2.5	3.5

Model Number*	Clearances (inches)				Approx Shipping Weight (lbs)
	Top	Bottom	Side	Front	
ATI-110-N	12	12	3	4	38
ATI-310-N	12	12	3	4	43
ATI-510-N	12	12	3	4	45

*For outdoor models, change "ATI" to "ATO". For propane models, change "N" to "P"

**For propane models, minimum inlet gas pressure is 8.0 in. W.C. and maximum inlet gas pressure is 14.0 in. W.C.

† Cold climate represents 70°F temperature rise

‡ Warm climate represents 50°F temperature rise

TANKLESS RESIDENTIAL & COMMERCIAL PROLINE® XE NON-CONDENSING ULTRA-LOW NOx



INDOOR MODEL



OUTDOOR MODEL



ANSI Z21.10.3

Ultra-Low NOx Emissions

- Complies with SCAQMD 1146.2 NOx emission requirements of 14 ng/J or 20 PPM.

Field Convertible from Natural Gas to Propane

Maximum Flow Rates Up To 10.0 GPM

Copper Primary Heat Exchanger

- Primary heat exchange of the ATI/ATO-510U is constructed of a commercial-grade copper that is more resilient to erosion. Copper is 25x better at heat transfer than stainless steel thus stabilizing outgoing water temperatures quicker and reducing pressure drop across the heat exchanger indoor and outdoor models available.

Indoor Models

- Include integrated temperature controls and advanced diagnostics to simplify troubleshooting.
- Include factory-installed power cords.

Outdoor Models

- Include a wall mount temperature remote controller and advanced diagnostics to simplify troubleshooting.

ATI-510U / ATO-510U Can be Used in Both Residential and Commercial Applications

- Easy-Link Up To 4 Units.
- Multi-Link Up to 20 Units.

Safety Features

- Air-Fuel Ratio (AFR) Sensor.
- Exhaust & Water Temperature Safety Control.
- Overheat Cut-Off Fuse.

Internal Freeze Protection

Power Vent or Power Direct Vent Design

Warranty

- 15-year limited warranty on heat exchanger in residential applications.
- 6-year limited warranty on heat exchanger in commercial applications.
- 5-year limited warranty on all parts.

INDOOR MODEL

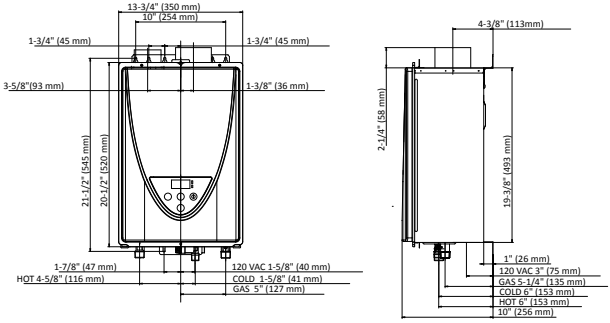

OUTDOOR MODEL

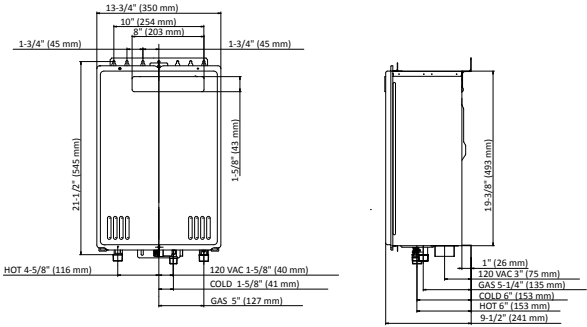

Model Number*	Type	Gas Consumption Input		Inlet Gas Pressure**	
		Minimum (BTU/H)	Maximum (BTU/H)	Minimum (in. W.C.)	Maximum (in. W.C.)
ATI-110U-200	Natural	15,000	140,000	4.0	10.5
ATI-310U-200	Natural	15,000	190,000	4.0	10.5
ATI-510U-200	Natural	15,000	199,000	4.0	10.5

Model Number*	Indoor Model UEF	Outdoor Model UEF	Connections		Sizing Chart (Number of Showers)	
			Water	Gas	Cold Climate†	Warm Climate‡
ATI-110U-200	0.81	0.81	3/4" NPT	3/4" NPT	1.5	2.5
ATI-310U-200	0.82	0.82	3/4" NPT	3/4" NPT	2.5	3.5
ATI-510U-200	0.82	0.81	3/4" NPT	3/4" NPT	2.5	3.5

Model Number*	Clearances (in.)				Approx Shipping Weight (lbs)
	Top	Bottom	Side	Front	
ATI-110U-200	12	12	3	4	39
ATI-310U-200	12	12	3	4	39
ATI-510U-200	12	12	3	4	40

*For outdoor models, change "ATI" to "ATO". Units are field convertible from natural gas to propane with supplied conversion kit.

**When converted for propane, minimum inlet gas pressure is 8.0 in. W.C. and maximum inlet gas pressure is 14.0 in. W.C.

† Cold climate represents 70°F temperature rise

‡ Warm climate represents 50°F temperature rise

COMMERCIAL TANKLESS NON-CONDENSING HEAVY-DUTY



Commercial-Grade Copper Heat Exchanger (Non-ASME Models)

ASME Models Available

5" Category III Stainless Steel Venting

Vertical or Horizontal Venting Installation

Power Vent or Convertible to Power Direct Vent

Electronic Ignition

Low NOx Emissions

Combined Indoor/Outdoor Models

Easy-Link up to 4 Units

Multi-Link up to 10 Units

Warranty

- 6-year limited warranty on heat exchanger
- 5-year limited warranty on all parts



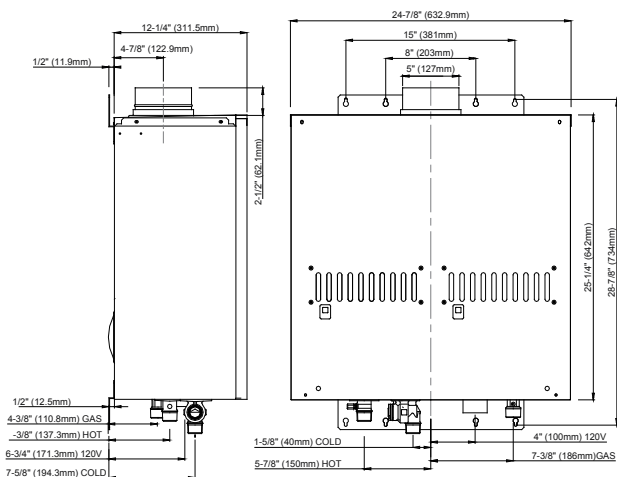

Model Number*	Type	Gas Consumption Input		Inlet Gas Pressure**	
		Minimum (BTU/H)	Maximum (BTU/H)	Minimum (in. W.C.)	Maximum (in. W.C.)
ATIO-910-N	Natural	15,000	380,000	5.0	10.5
ATIO-910-AN	Natural	15,000	380,000	5.0	10.5

Model Number*	Thermal Efficiency	Connections		Sizing Chart (Number of Showers)	
		Water	Gas	Cold Climate†	Warm Climate‡
ATIO-910-N	80%	1" NPT	1" NPT	5	7
ATIO-910-AN	80%	1" NPT	1" NPT	5	7

Model Number*	Clearances (in.)				Approx Shipping Weight (lbs)
	Top	Bottom	Side	Front	
ATIO-910-N	12	12	2	24	113
ATIO-910-AN	12	12	2	24	113

** -AN" means ASME rated. For propane models, change "N" to "P".

**For propane models, minimum inlet gas pressure is 8.0 in. W.C. and maximum inlet gas pressure is 14.0 in. W.C.

† Cold climate represents 70°F temperature rise

‡ Warm climate represents 50°F temperature rise

COMMERCIAL TANKLESS RACK SYSTEM



Freestanding



Wall Mount



Back-to-Back

Multiple Design and Installation Configurations

- Wall mount, freestanding in-line, and freestanding back-to-back designs
- Indoor and outdoor rack designs
- Uses the 540H high efficiency condensing tankless heaters.

Expandable

- Up to 1,592,000 BTU on a single rack system
- Able to link up to 20 heaters together with Multi-Link system

Redundancy

- Multiple combustion systems provide piece of mind
- Easily isolate a unit for maintenance which extends the life of the heaters

Lightweight

- Anodized aluminum frame
- Utilizes the industry's lightest 199,000 BTU high efficiency condensing tankless heater

Easy Field Installation

- Reduce installation costs with three simple connections (cold water, hot water, and gas)

Ultra-Low NOx Emissions

- Complies with SCAQMD Rule 1146.2 NOx emission requirements of 14 ng/J or 20 PPM.

Warranty

- 1-year limited warranty on rack parts

Model Number	Number of Heaters	Btuh Input		Max Flow (GPM)		
		Min	Max	@ 40°F Rise	@ 100°F Rise	@ 140°F Rise
Freestanding						
ATI-CRS-2IL-N	2	15,000	398,000	18.8	7.6	5.4
ATI-CRS-3IL-N	3	15,000	597,000	28.2	11.4	8.1
ATI-CRS-4IL-N	4	15,000	796,000	37.6	15.2	10.8
Wall Mount						
ATI-CRS-2WM-N	2	15,000	398,000	18.8	7.6	5.4
ATI-CRS-3WM-N	3	15,000	597,000	28.2	11.4	8.1
ATI-CRS-4WM-N	4	15,000	796,000	37.6	15.2	10.8
Back-to-Back						
ATI-CRS-4B2B-N	4	15,000	796,000	37.6	15.2	10.8
ATI-CRS-5B2B-N	5	15,000	995,000	47.0	19.0	13.5
ATI-CRS-6B2B-N	6	15,000	1,194,000	56.4	22.8	16.2
ATI-CRS-7B2B-N	7	15,000	1,393,000	65.8	26.6	18.9
ATI-CRS-8B2B-N	8	15,000	1,592,000	75.2	30.4	21.6

*For outdoor models, change ATI to ATO

**For Propane, change -N to -P

COMMERCIAL TANKLESS RACK SYSTEM (CONTINUED)

Freestanding

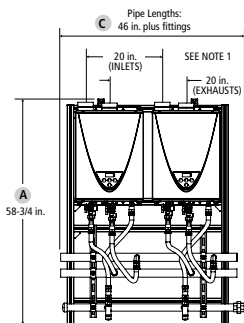

Front

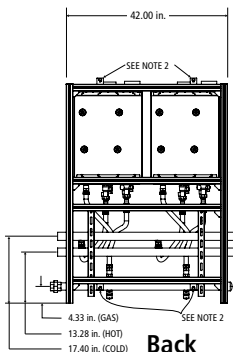

Back

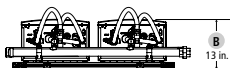

Bottom

- NOTES:
1. TOP-MOUNTED AIR SUPPLY INLET/EXHAUST VENTS ARE USED WITH INDOOR MODELS ONLY.
 2. MOUNTING BRACKETS ADJUST HORIZONTALLY ALONG CHANNEL SLOTS.
 3. INDOOR AND OUTDOOR RACK SYSTEMS HAVE IDENTICAL DIMENSIONS. EXCEPTION: INDOOR MODELS HAVE TOP-MOUNTED INTAKES AND EXHAUSTS. OUTDOOR MODELS DO NOT.

Wall Mount

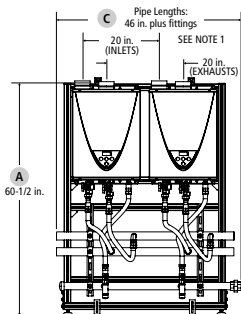

Front

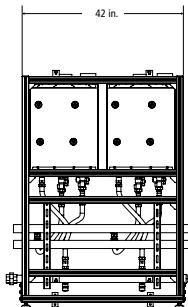

Back

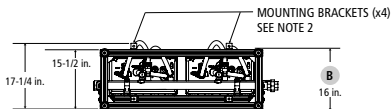

Bottom

- NOTES:
1. TOP-MOUNTED AIR SUPPLY INLET/EXHAUST VENT ARE USED WITH INDOOR MODELS ONLY.
 2. MOUNTING BRACKETS ADJUST HORIZONTALLY ALONG CHANNEL SLOTS.
 3. INDOOR AND OUTDOOR RACK SYSTEMS HAVE IDENTICAL DIMENSIONS. EXCEPTION: INDOOR MODELS HAVE TOP-MOUNTED INTAKES AND EXHAUSTS. OUTDOOR MODELS DO NOT.

Back-to-Back

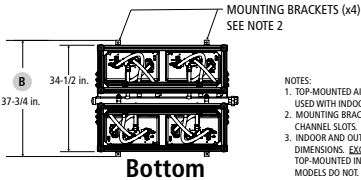
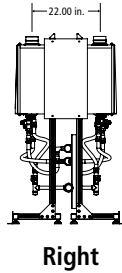
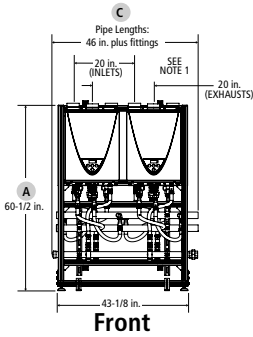

- NOTES:
1. TOP-MOUNTED AIR SUPPLY INLET/EXHAUST VENT ARE USED WITH INDOOR MODELS ONLY.
 2. MOUNTING BRACKETS ADJUST HORIZONTALLY ALONG CHANNEL SLOTS.
 3. INDOOR AND OUTDOOR RACK SYSTEMS HAVE IDENTICAL DIMENSIONS. EXCEPTION: INDOOR MODELS HAVE TOP-MOUNTED INTAKES AND EXHAUSTS. OUTDOOR MODELS DO NOT.

Model Number	Dimensions in Inches			Approx. Shipping Weight (lbs)
	A Height	B Depth	C Width	
Free Standing				
ATI-CRS-2IL-N	60-1/2	16	46	265
ATI-CRS-3IL-N	60-1/2	16	66	387
ATI-CRS-4IL-N	60-1/2	16	86	580
Wall Mount				
ATI-CRS-2WM-N	58-3/4	13	46	240
ATI-CRS-3WM-N	58-3/4	13	66	350
ATI-CRS-4WM-N	58-3/4	13	86	460
Back-to-Back				
ATI-CRS-4B2B-N	60-1/2	37-3/4	46	580
ATI-CRS-5B2B-N	60-1/2	37-3/4	66	741
ATI-CRS-6B2B-N	60-1/2	37-3/4	66	800
ATI-CRS-7B2B-N	60-1/2	37-3/4	85	961
ATI-CRS-8B2B-N	60-1/2	37-3/4	85	1020

*For outdoor models, change ATI to ATO

**For Propane, change -N to -P

BUILDING MANAGEMENT SYSTEM BACnet & MODBUS INTERFACE

Connect Your A. O. Smith Water Heater to your Building Management System Using the New Millennium Control from ICC (Industrial Control Communications, Inc.)

- Works with Cyclone, McBee DVE, Renton DSE/DVE/DHE (Except BTX-80)
- Use the ICC Control to enable/disable the water heater
- Change Temperature Set points and differentials
- Two models with four different configurations to connect to BACnet and Modbus
- Ethernet and Serial RS-485 versions available
- 2 wire or 4 wire RS-485 Network
- Power can be supplied via the USB cable, as a 7-24 VDC input on the main terminal Block, or via IEEE 802.3af Power over Ethernet (PoE on ETH-1000 only)
- Configure protocols, network characteristics, and client/server object definitions
- Graphically interact with the internal database in real-time via USB connection
- Automatically discover and configure IP settings Ethernet gateways connected to the current subnet
- Update Firmware

INTRODUCING THE BMS GATEWAY FOR CONTROL OF A. O. SMITH WATER HEATERS

MODELS:

ETH-1000
Ethernet Connection
(Shown)

XLTR-1000
Serial RS-485 Connection



ICC Energy Management Interfaces			
Protocol	Part Number	Connection Type	Application
BACnet	100131364	Serial (RS485)	Commercial Gas - Cyclone® BTH and BTX (L)-100
	100131365		Commercial Electric DSE, DVE, DHE
	100131370	Ethernet (IP)	Commercial Gas - Cyclone® BTH and BTX (L)-100
	100131371		Commercial Electric DSE, DVE, DHE
Modbus	100131371	Serial (RS485)	Commercial Gas - Cyclone® BTH and BTX (L)-100
	100131368		Commercial Electric DSE, DVE, DHE
	100131373	Ethernet (IP)	Commercial Gas - Cyclone® BTH and BTX (L)-100
	100131374		Commercial Electric DSE, DVE, DHE

- Heater connection wiring supplied with unit
- For questions on this product Call 888-928-3702 Opt 2w
- RTU and serial connect via RS-485
- Ethernet and IP connect via RJ-45



Power Vent Design for Installation Versatility

- Helical internal heat exchanger achieves 90% thermal efficiency, which saves money on operating costs compared to a standard 80% efficient gas water heater.
- Combined vertical and horizontal runs terminating through an outside wall, using Schedule 40 PVC, CPVC or polypropylene pipe; Canadian installations require ULC S636 approved pipe for venting
 - 2" pipe allows vent runs up to 25 equivalent feet
 - 3" pipe allows vent runs up to 65 equivalent feet
 - 4" pipe allows vent runs up to 128 equivalent feet

High Output with Small Footprint

- 22" diameter, combined with 90% efficiency, 50-gallon tank and 76,000 BTU input means Cyclone® HE can be installed in less space than a larger 75-gallon unit, with equal or better performance.

Side-Mounted Hot and Cold Recirculating Taps

Two Heavy-Duty Anode Rods

3-Year Limited Tank and 1-Year Limited Parts Warranty

- For complete warranty information, consult written warranty or go to hotwater.com.

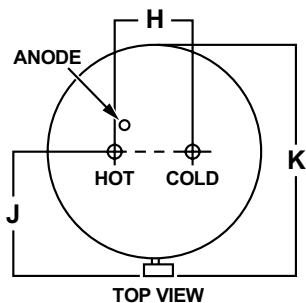

*INSTALL IN ACCORDANCE WITH LOCAL CODES

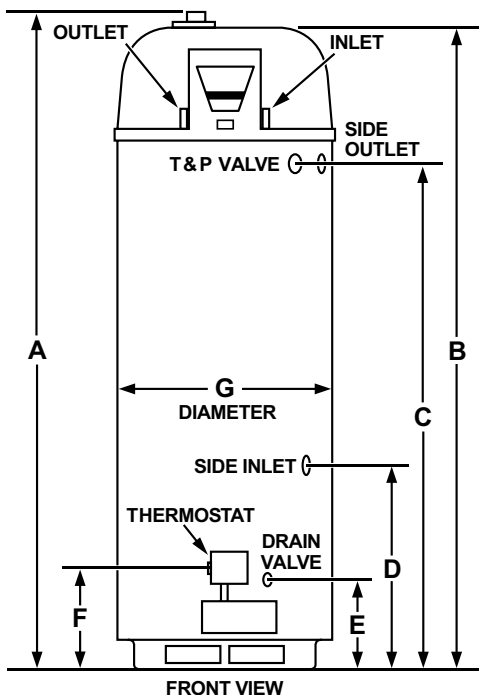

Model Number	Gallon Capacity	Recovery Capacity GPH @ 100°F Rise	BTU Input Per Hour	Approx. Shipping Weight (lbs)
BTX-80	50	83	76,000	210

Model Number	Dimensions in Inches				
	A	B	C	D	E
BTX-80	71	68-5/8	52	21	9-1/8

Model Number	Dimensions in Inches				
	F	G	H	J	K
BTX-80	12	22	8	15-3/4	27

Available in Natural Gas only.

Standard model certified from sea level to 5,300 ft. elevation. Order SMR S54 for elevations to 10,100 ft.

Optional Condensate Neutralization Kits available (Part Number 100112380).

COMMERCIAL GAS CYCLONE® Xi



Condensing Design

- Operates at 96% thermal efficiency, which saves money on operating costs compared to a standard 80% efficient gas water heater.
- Equipped with condensate drain tee

Helical Internal Heat Exchanger

- Spiral heat exchanger keeps hot combustion gases in the tank longer to lengthen the heat transfer cycle
- Positioned in the center of the tank for more even heat distribution

Power Direct Vent Design

- Combined vertical and horizontal runs terminating through an outside wall. Vents using PVC, CPVC, or polypropylene piping; Canadian installations require ULC S636 approved pipe for venting.
 - 2" pipe, vents up to 45 equivalent feet
 - 3" pipe, vents up to 128 equivalent feet

Side-Mounted Hot and Cold Recirculating Taps

3-Year Limited Tank and 1-Year Limited Parts Warranty

- For complete warranty information, consult written warranty or go to hotwater.com.



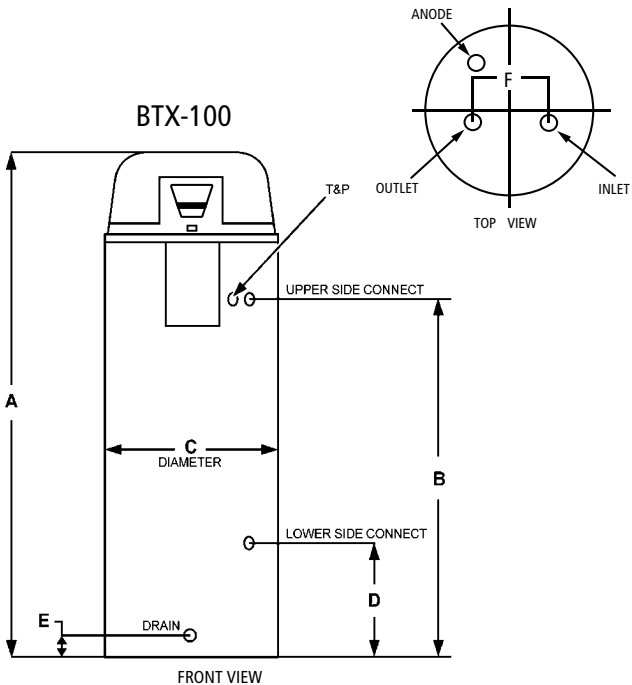

Model Number	Gallon Capacity	Recovery Capacity GPH @ 100°F Rise	BTU Input Per Hour	Approx. Shipping Weight (lbs)
BTX-100	50	116	100,000	255

Model Number	Dimensions in Inches					
	A	B	C	D	E	F
BTX-100	66-3/4	49-1/4	22	15-3/4	3	8

Standard model certified from sea level to 10,100 ft. elevation.
 Optional Concentric Vent Kits (100109357) and Condensate Neutralization Kits (100112380).
 Specify when ordering propane (LP) gas.



Condensing Design

- Operates at 96% thermal efficiency, which saves money on operating costs compared to a standard 80% efficient gas water heater.
- Equipped with condensate drain tee

Helical Internal Heat Exchanger

- Spiral heat exchanger keeps hot combustion gases in the tank longer to lengthen the heat transfer cycle
- Positioned in the center of the tank for more even heat distribution

Power Direct Vent Design

- Combined vertical and horizontal runs terminating through an outside wall. Vents using PVC, CPVC, or polypropylene piping; Canadian installations require ULC S636 approved pipe for venting.
 - 2" pipe, vents up to 45 equivalent feet
 - 3" pipe, vents up to 128 equivalent feet

Side-Mounted Hot and Cold Recirculating Taps

3-Year Limited Tank and 1-Year Limited Parts Warranty

- For complete warranty information, consult written warranty or go to hotwater.com.



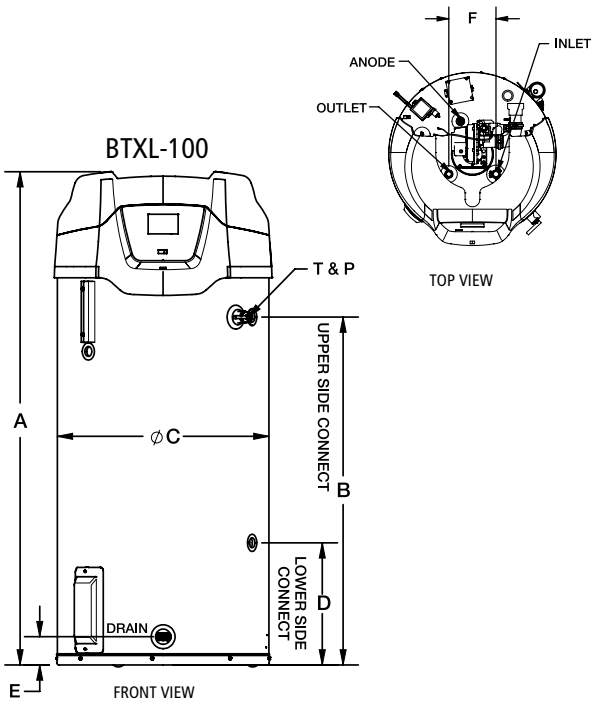

Model Number	Gallon Capacity	Recovery Capacity GPH @ 100°F Rise	BTU Input Per Hour	Approx. Shipping Weight (lbs)
BTXL-100	75	116	100,000	382

Model Number	Dimensions in Inches					
	A	B	C	D	E	F
BTXL-100	65-1/4	45-5/8	27-3/4	16	3-3/4	8

Standard model certified from sea level to 10,100 ft. elevation.
 Optional Concentric Vent Kits (100111100) and Condensate Neutralization Kits (100112380).
 Specify when ordering propane (LP) gas.

COMMERCIAL GAS

CYCLONE® MXi—MODULATING

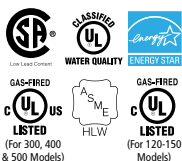

High Efficiency Modulating Pre-Mix Powered Burner

- Down-fired pre-mix burner provides optimum efficiency and quiet operation
- Top-mounted burner position prevents condensation from affecting burner operation

Up to 98% Efficient

Intelligent Control System with Touch Screen Display

- Exclusive A. O. Smith designed control system
- Provides detailed water heater status information
- Precise temperature control adjustable from 90 to 180 degrees
- Built-in diagnostics
- Run history information
- Cyclone water heaters include iCOMM remote connectivity; models 120-250 require optional Wi-Fi communications kit, models 300-500 come standard with Wi-Fi connectivity.
- Convenient iOS and Android Phone App

Submerged Combustion Chamber with Helical Heat Exchanger Coil

- Positioned in center of tank, surrounded by water to virtually eliminate radiant heat loss from chamber
- Direct spark ignition
- Spiral heat exchanger keeps hot burner gases swirling, uses centrifugal force to maximize efficiency of heat transfer to water in tank
- Spiral heat exchanger reduces lime scale from forming on water-side surfaces, which maintains energy efficiency over time

Power Anodes Standard on All Models

- Provides long-lasting tank protection in varying water conditions
- Powered anodes are non-sacrificial
- Automatically adjusts output needed to properly protect the tank

3-Year Limited Tank and 1-Year Limited Parts Warranty

- For complete warranty information, consult written warranty or go to hotwater.com

Model Number	Gallon Capacity	Recovery Capacity	Input BTU/HR
BTH-120(A)	60	138	120,000
BTH-150(A)	100	178	150,000
BTH-199(A)	100	235	199,900
BTH-250(A)	100	291	250,000
BTH-300(A)	119	349	300,000
BTH-400(A)	119	460	399,000
BTH-500(A)	119	576	499,000

Model Number	Approx. Shipping Weight (lbs) Std	Approx. Shipping Weight (lbs) ASME
BTH-120(A)	460	490
BTH-150(A)	523	553
BTH-199(A)	523	553
BTH-250(A)	523	553
BTH-300(A)	855	855
BTH-400(A)	855	855
BTH-500(A)	855	855

Optional Concentric Vent Kits 100111100 (BTH-120 through BTH-250 models).
100113124 (BTH-300 through BTH-500 models).

Electrical characteristics- 120V-60 Hz A.C., 5.0A.

"A" in the model number represents ASME construction.

Models are certified from sea level to 10,100 ft. elevation.

Line drawings and dimensions on the following page.

COMMERCIAL GAS

CYCLONE® MXi—MODULATING (CONTINUED)

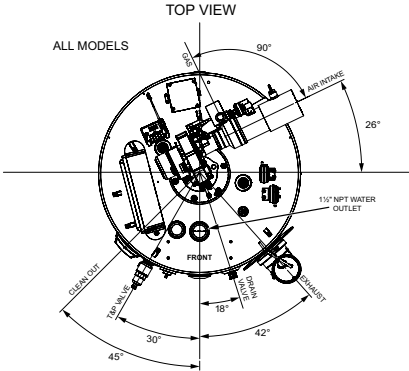
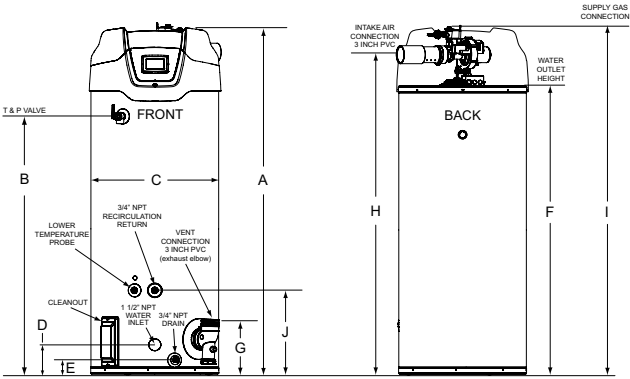

* Center line of water outlet on top of the water heaters is approximately 7 inches from the front edge of the water heater

Model Number	Dimensions in Inches				
	A	B	C	D	E
BTH-120(A)	3	27.75	6.3	35	53.5
BTH-150(A)	3	27.75	6.3	56.38	75.75
BTH-199(A)	3	27.75	6.3	56.38	75.75
BTH-250(A)	3	27.75	6.3	56.38	75.75

Model Number	Dimensions in Inches				
	F	G	H	I	J
BTH-120(A)	55.5	11.25	42.25	48.5	18.25
BTH-150(A)	76	11.25	64	70	18.25
BTH-199(A)	76	11.25	64	70	18.25
BTH-250(A)	76	11.25	64	70	18.25

Optional Concentric Vent kit 100113124 (BTH-300 through BTH-500 models).

Electrical characteristics- 120V-60 Hz A.C., 5.0A.

"A" in the model number represents ASME construction.

Models are certified from sea level to 10,100 ft. elevation.

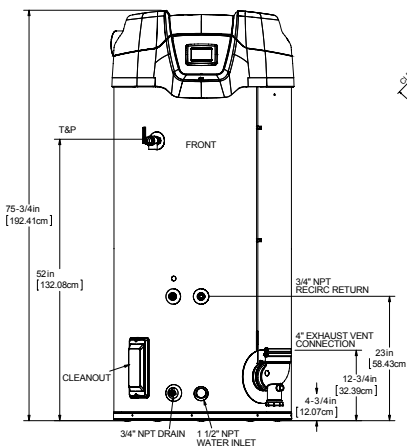
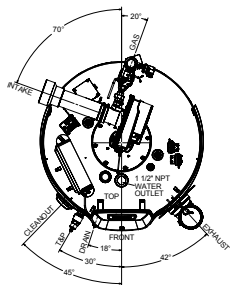
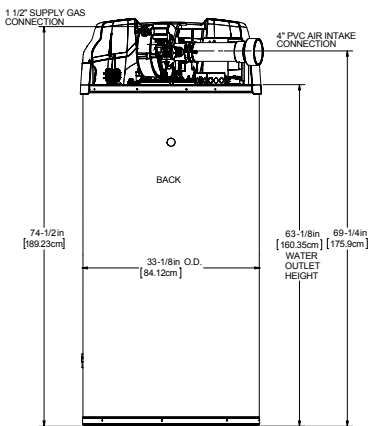

Model Number	Dimensions in Inches				
	A	B	C	D	E
BTH-300(A)	4.75	33.12	4.75	52	75.75
BTH-400(A)	4.75	33.12	4.75	52	75.75
BTH-500(A)	4.75	33.12	4.75	52	75.75

Model Number	Dimensions in Inches				
	F	G	H	I	J
BTH-300(A)	73.75	12.75	63.13	69.25	23
BTH-400(A)	73.75	12.75	63.13	69.25	23
BTH-500(A)	73.75	12.75	63.13	69.25	23

Optional Concentric Vent kit 100113124 (BTH-300 through BTH-500 models).

Electrical characteristics- 120V-60 Hz A.C., 5.0A.

"A" in the model number represents ASME construction.

Models are certified from sea level to 10,100 ft. elevation.

COMMERCIAL GAS

POLARIS® HIGH EFFICIENCY



Condensing Design

- Operates at up to 96% thermal efficiency which saves money on operating costs compared to a standard 80% efficient gas water heater.
- Helical internal heat exchanger keeps hot combustion gases in the tank longer to extract more heat into the water.
- Modulating burner maintains high efficiency operation at lower input rates.

Stainless Steel Construction

- Tank and helical heat exchanger are constructed from 444 stainless steel for excellent corrosion resistance without the need for an anode.

Whisper Quiet Operation

- Ultra quiet blower and burner minimize noise.

Power Direct Vent Design

- Direct vent using PVC, CPVC or ABS either thru-the-wall or thru-the-roof.
- Optional concentric vent kit

Advanced Electronic Control

- Large LCD display provides precise temperature control and advanced diagnostics.

Code Compliance

- Complies with SCAQMD Rule 1146.2 and other air quality management districts with similar requirements for Ultra-Low NOx emissions requirements of 14 ng/J or 20 PPM.
- Meets UBC, CEC, and ICC National Codes.
- Meets the thermal efficiency and standby loss requirements of the U. S. Department of Energy and current edition of ASHRAE/IES 90.1.

3-Year Limited Tank and 1-Year Limited Parts Warranty

- For complete information, consult written warranty or go to hotwater.com.



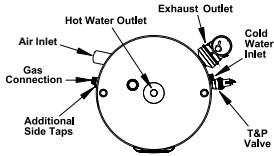

TOP

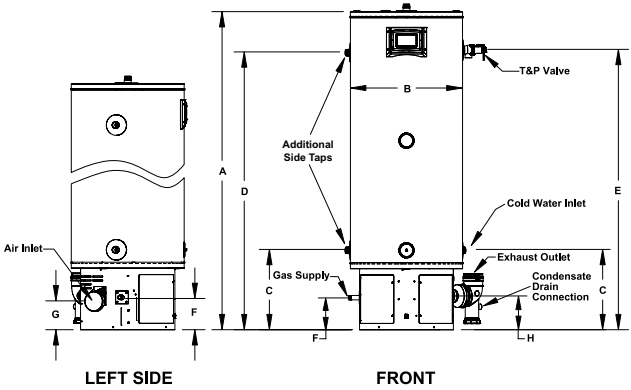

LEFT SIDE

FRONT

Model Number	Gallon Capacity	BTU/h Input Gallon Per Hour	Thermal Efficiency	Recovery @ 100° Rise Gallon Per Hour	Dimensions in Inches	
					A	B
BSS 130	34	130,000	96%	149	48-1/2	22
BSS 150	34	150,000	94%	171	48-1/2	22
BTS 130	50	130,000	95%	149	62-3/8	22
BTS 150	50	150,000	95%	171	63-3/4	22
BTS 175	50	175,000	96%	200	63-3/4	22
BTS 199	50	199,000	96%	227	63-3/4	22

Model Number	Vent Connection	1" Water Connections		T&P E	Gas Supply* F	Approx. Shipping Weight (lbs)
		C	D			
BSS 130	2 or 3	15-3/4	40-1/2	41	6-3/8	150
BSS 150	2 or 3	15-3/4	40-1/2	41	6-3/8	150
BTS 130	2 or 3	15-3/4	54-1/2	55	6-3/8	176
BTS 150	2 or 3	15-3/4	55-3/4	56-1/4	6-3/8	180
BTS 175	3	15-3/4	55-3/4	56-1/4	6-3/8	180
BTS 199	3	15-3/4	55-3/4	56-1/4	6-3/8	180

Available in Propane (LP) gas. Specify when ordering Propane (LP) gas.
Models certified for sea level to 7,700 ft. elevation.

COMMERCIAL GAS

MASTER-FIT® BTR



The Eliminator™ Self-Cleaning System

- Designed to significantly reduce or eliminate sediment build-up inside the tank
- Reduced sediment build-up maintains rated thermal efficiency and reduces water heating costs
- Self-cleaning system maximizes tank life

Factory-Installed Draft Diverter and Automatic Flue Damper (BTR-120-400 Models)

- BTR-500 Model features induced draft design and no damper
- Low-profile draft diverter helps for installation in tight spaces
- Automatic motorized flue damper helps minimize standby heat loss

Three Water Connection Options for Added Flexibility

- Hot and cold water connections can be made through front, top or rear of unit
- Eliminator™ system operates when cold water is connected through front

3-Year Limited Tank and 1-Year Warranty

- For complete warranty information, consult written warranty or go to hotwater.com



Model Number	Gallon Capacity	Input BTU/HR Natural Gas	Recovery Capacity GPH @ 100°F Rise
BTR-120*	71	120,000	116
BTR-154	81	154,000	149
BTR-180	81	180,000	175
BTR-197	100	199,000	193
BTR-198	100	199,000	193
BTR-199	81	199,000	193
BTR-200 (A)	100	199,000	193
BTR-250* (A)	100	250,000	242
BTR-251* (A)	65	251,000	243
BTR-275* (A)	100	275,000	267
BTR-305 (A)	65	305,000	296
BTR-365 (A)	85	365,000	354
BTR-400 (A)	100	390,000	378
BTR-500 (A)	85	500,000	485

Specify when ordering propane (LP) gas.

*Model BTR 120 is shipped with 6" x 5" flue outlet adapter. Models BTR 250, 251 and 275 are shipped with a 8" x 6" flue outlet adapter.

Standard models certified from sea level to 2,000 ft. elevation. Order SMR S54 for elevations up to 8,000 ft.

BTR-500 model features induced draft design and no damper.

Line drawings and dimensions on the following page.

COMMERCIAL GAS
MASTER-FIT® BTR (CONTINUED)

Master-Fit BTR 120-400

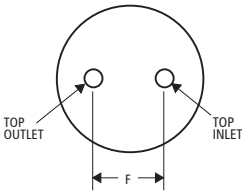
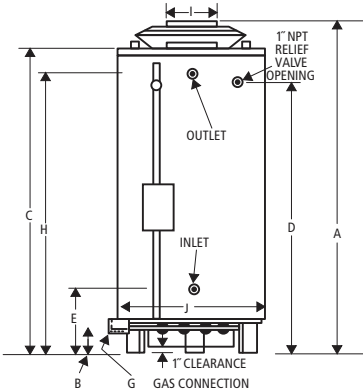

MODEL
BTR-120-400

Master-Fit BTR 500

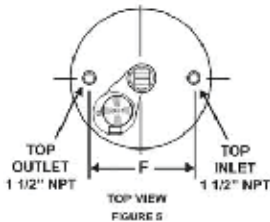
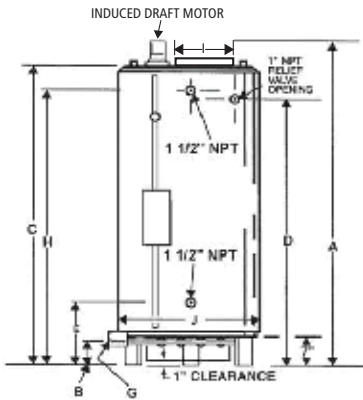

MODEL
BTR-500

Model Number	Dimensions in Inches					
	A	B	C	D	E	F
BTR-120*	69-3/4	4-1/4	59-1/2	50-7/8	19-11/16	19
BTR-154	73	4-1/4	66-1/2	57-7/8	19-11/16	19
BTR-180	67-1/2	4-1/2	62	53-5/8	20-1/2	21
BTR-197	75	4-1/2	70	61-5/8	20-1/2	21
BTR-198	75	4-1/2	70	61-5/8	20-1/2	21
BTR-199	67-1/2	4-1/2	62	53-5/8	20-1/2	21
BTR-200(A)	72	4-1/2	65-1/8	55-7/8	19-3/4	23
BTR-250*(A)	72	4-1/2	65-1/8	55-7/8	19-3/4	23
BTR-251*(A)	75	4-1/2	65-3/4	57-1/4	20	N/A
BTR-275*(A)	72	4-1/2	65-1/8	55-7/8	19-3/4	23
BTR-305 (A)	75	4-1/2	65-3/4	57-1/4	20	N/A
BTR-365 (A)	79-1/2	4-1/2	70-1/4	62-1/2	22-1/2	23
BTR-400 (A)	75-1/2	4-1/2	67-1/2	58-1/4	26-3/4	23
BTR-500 (A)	81-1/2	17-1/2	77-1/4	67-1/2	27	21

Model Number	Dimensions in Inches				Approx. Shipping Weight (lbs)	
	G	H	I	J	Standard	ASME
BTR-120*	1/2	51-7/8	6	27-3/4	400	-
BTR-154	1/2	59	6	27-3/4	470	-
BTR-180	1/2	54-5/8	6	27-3/4	470	-
BTR-197	1/2	62-5/8	6	27-3/4	603	-
BTR-198	1/2	61-1/2	6	27-3/4	603	-
BTR-199	1/2	54-5/8	6	27-3/4	470	-
BTR-200(A)	1/2	56-3/8	6	30-1/4	630	725
BTR-250*(A)	1/2	56-3/8	8	30-1/4	630	725
BTR-251*(A)	1/2	58-3/4	8	27-3/4	750	862
BTR-275*(A)	1/2	56-3/8	8	30-1/4	630	725
BTR-305 (A)	1/2	58-3/4	8	27-3/4	750	862
BTR-365 (A)	3/4	63	8	27-3/4	725	833
BTR-400 (A)	3/4	59	8	30-1/4	760	874
BTR-500 (A)	1	67-1/2	8	27-3/4	812	857

Specify when ordering propane (LP) gas.

*Model BTR 120 is shipped with 6" x 5" flue outlet adapter. Models BTR 250, 251 and 275 are shipped with a 8" x 6" flue outlet adapter.

Standard models certified from sea level to 2,000 ft. elevation. Order SMR S54 for elevations up to 8,000 ft.

BTR-500 model features induced draft design and no damper.

MASTER-FIT® ULTRA-LOW NOx



80% Thermal Efficiency means Lower Operating Costs

Fan Assisted Combustion

- The blower is built into the low NOx burner assembly
- Complies with California SCAQMD Rule 1146.2 and other Air Quality Management Districts with similar NOx emission requirements of 14 ng/J or 20 ppm

Air-Flapper

- A stainless steel air flapper is used inside the premix system to replace externally mounted flue damper to minimize the standby heat loss and to minimize the overall heater height

Metal Venting

- Rated Category I Appliance. Uses standard double wall type "B" vent.
- Can be commonly vented with other Category I appliances
- Vent connects directly to the vent connector outlet
- An excellent choice for retrofit and upgrade installations

3-Year Limited Tank/1-Year Limited Parts Warranty

- For complete warranty information, consult written warranty or go to hotwater.com.



Model Number	Gallon Capacity	Input BTU/HR	Recovery Capacity GPH @ 100°F Rise
BTL-120	81	120,000	115
BTL-154	81	154,000	148
BTL-180	81	180,000	173
BTL-198	81	199,000	191
BTL-199	100	199,000	191
BTL-250	100	250,000	240
BTL-275	100	275,000	264
BTL-310	86	310,000	298
BTL-366	86	366,000	352
BTL-400	86	390,000	375
BTL-250A	100	250,000	240
BTL-275A	100	275,000	264
BTL-310A	86	310,000	298
BTL-366A	86	366,000	352
BTL-400A	86	390,000	375

Electrical characteristics—120V-60 Hz A. C., 5.0A.

(A) after model number designates ASME construction.

LEG KITS FOR UL SANITATION TO MEET NSF-5 (increases overall height by 4").

BTL models not available in LP gas.

Line drawings and dimensions on the following page.

MASTER-FIT® ULTRA-LOW NO_x

(CONTINUED)

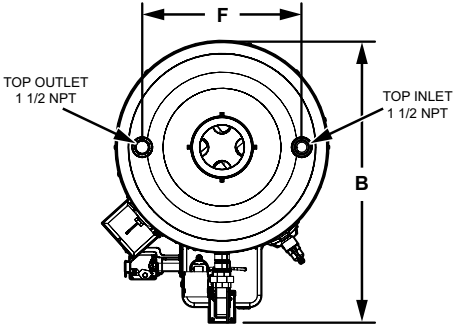

TOP VIEW

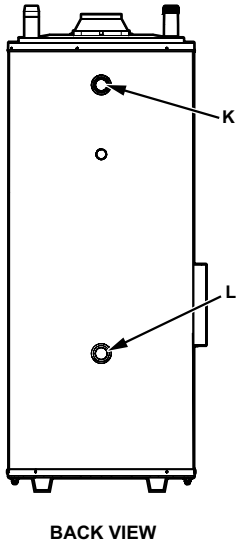
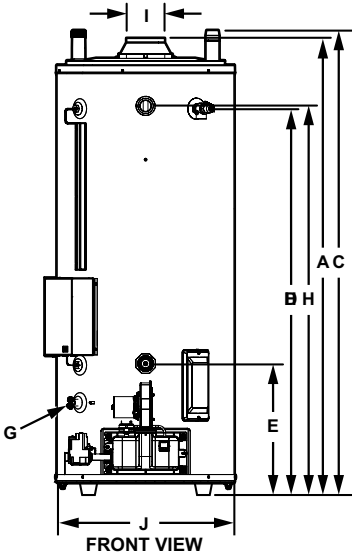

Letter	BTL-120, 154, 180, 198	BTL-199, 250(A), 275(A)	BTL-310(A), 366(A), 400(A)
	Dimensions in Inches		
A	63-3/4	71-3/4	71-3/4
B	37	37	37
C	65	73	73
D	52-3/4	60-3/4	60-3/4
E	20-3/4	20-1/2	20-1/2
F	21	21	21
G	3/4 NPT		
H	53	61	61
I	6	6	6
J	27-3/4	27-3/4	27-3/4
K	1-1/2 NPT		
L	1-1/2 NPT		

Approx. Shipping Weight (lbs)	BTL-120, 154, 180, 198	BTL-199, 250(A), 275(A)	BTL-310(A), 366(A), 400(A)
Standard	650	750	810
ASME	N/A	800	860

Electrical characteristics—120V-60 Hz A. C., 5.0A.

(A) after model number designates ASME construction.

LEG KITS FOR UL SANITATION TO MEET NSF-5 (increases overall height by 4”).

BTL models not available in LP gas.

COMMERCIAL GAS CONSERVATIONIST® BT



Glasslined Tank

- Maximizes tank life.
- Fully Automatic Controls with Safety Shutoff
- Accurate, dependable control system requires no electric connections. Fixed automatic gas shutoff device for added safety. Not recommended for 180°F sanitizing.

Heavy Gauge Steel Jacket

- Finished with baked enamel over bonderized undercoat.

Foam Insulation

- Saves fuel, helps reduce standby heat loss.
- Low NOx

Complies with Texas and other Districts Requirements for NOx Emissions Less than 40 ng/j

Easy-to-Install

- Completely factory-assembled. Only gas, water and vent connections need be made. All connections are located in front and top of heaters for ease of installation and service.

3-Year Limited Tank / 1-Year Limited Parts Warranty

- For complete warranty information, consult written warranty or go to hotwater.com.



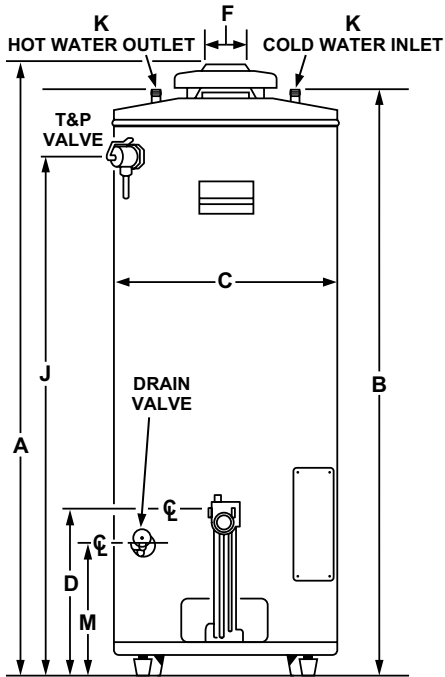
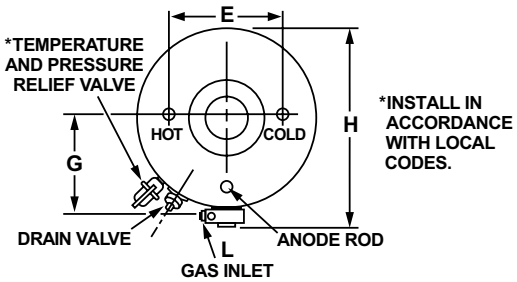

Model Number	Gallon Capacity	Input Rating BTU/HR	Recovery Capacity GPH @ 100°F Rise	Approx. Shipping Weight (lbs)
BT-80	74	75,100	73	275
BT-100	98	75,100	73	350

Model Number	Dimensions in Inches					
	A	B	C	D	E	F
BT-80	61-1/8	58-1/2	26-1/2	15-3/16	16	4
BT-100	68-5/8	66-1/2	27-3/4	15-3/16	16	4

Model Number	Dimensions in Inches					
	G	H	J	K	L	M
BT-80	14-1/2	29-11/16	54-1/4	1	1/2	11-15/16
BT-100	15-3/4	30-15/16	54-1/4	1	1/2	11-15/16

NSF leg kit 100111360.
Specify when ordering (LP) gas.

COMMERCIAL GAS

CONSERVATIONIST® POWER VENT



Approval Rating and Certification

- All models comply with ANSI Z21.10.3/CSA 4.3 and ASHRAE/IES 90.1-2004
- Meets Texas and other low NOx areas requiring 40 ng/J
- All models are approved for use in combined appliance applications.

CFC Free Foam Insulation

- Minimize radiant heat loss

Dip Tube

- Carries inlet water deep into the tank

Hot Surface Ignition

- Has a solid state ignition surface that does not flutter or blow out
- Provides increased reliability and efficiency over spark ignition systems. Eliminates the pilot and saves energy

User-Friendly

- State-of-art electronic gas control provides more precise temperature control.
- LED control light displays operation status and diagnostics

3-Year Limited Tank/1-Year Limited Parts Warranty

- For complete warranty information, consult written warranty or go to hotwater.com.



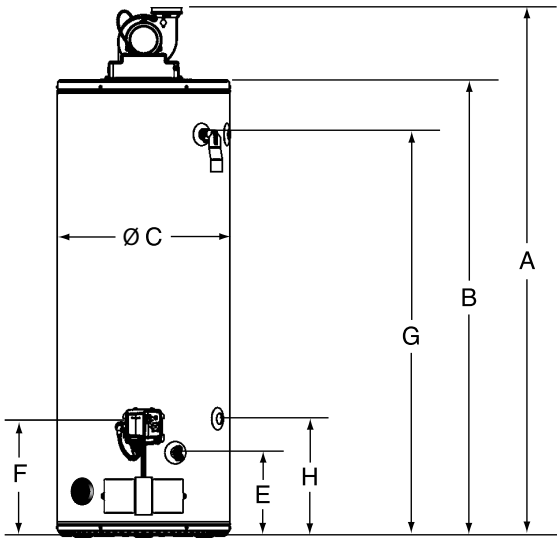
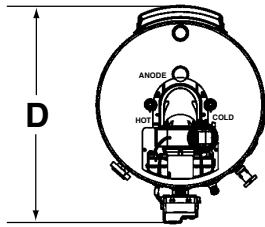

Model Number	Gallon Capacity	Btuh Input	Approx. Shipping Weight
BTf-80	75	76,000	277 lbs

Model Number	Dimensions in inches			
	A	B	C	D
BTf-80	70-5/8	61-1/4	26	33-1/8

Model Number	Dimensions in inches			
	E	F	G	H
BTf-80	11	13-1/4	53	15-1/4

Recovery capacity based on 81% thermal efficiency.
 Available in LP (Propane) gas.
 Can be installed up to 10,100 feet without alteration.

COMMERCIAL GAS

CONSERVATIONIST® POWER DIRECT VENT



DynaClean™ Diffuser Dip Tube

- Helps reduce lime and sediment buildup and maximizes hot water output. Made from long-lasting PEX cross-linked polymer

Blue Diamond® Glass Coating

- Provides superior corrosion resistance compared to the industry-standard glasslining.

Hot Surface Ignition

- Has a solid state ignition surface that does not flutter or blow out
- Provides increased reliability and efficiency over spark ignition systems. Eliminates the pilot and saves energy.

Standards

- Design-certified by CSA International, according to ANSI Z21.10.3-CSA 4.3 standards governing storage-type water heaters.
- Meets the thermal efficiency and standby loss requirements of the U.S. Department of Energy and current edition of ASHRAE/IES 90.1.

3-Year Limited Tank/1-Year Limited Parts Warranty

- For complete warranty information, consult written warranty or go to hotwater.com



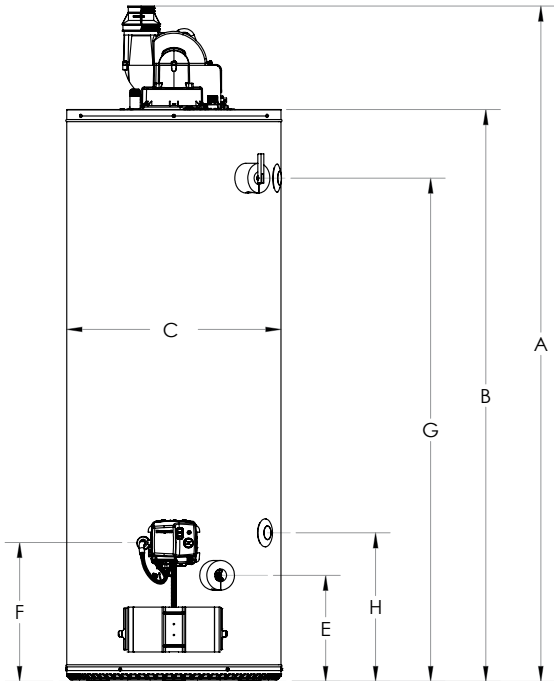
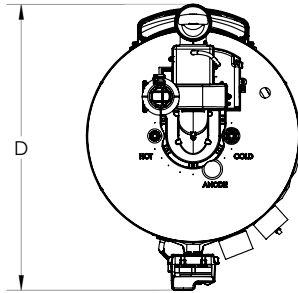

Model Number	Gallon Capacity	Btuh Input	Approx. Shipping Weight (lbs)
BPD-80	75	72,000	277

Model Number	Dimensions in Inches							
	A	B	C	D	E	F	G	H
BPD-80	70-5/8	61-1/4	26	33-1/8	11	13-1/4	53	15-1/4

Specify when ordering propane (LP) gas.
 Can be installed up to 10,100 feet without alteration.
 Recovery capacity based on 81% thermal efficiency.

CONSERVATIONIST® ULTRA-LOW NOx



AURI CERTIFIED®
www.auridirectory.org

Code Compliance

- The Ultra-Low NOx atmospheric vent commercial gas water heater which meets the thermal efficiency and standby loss requirements of the U.S. Department of Energy and Current Edition ASHRAE/IES 90.1.

Fully Automatic Controls with Safety Shutoff

- Accurate, dependable control system requires no electric connections. Fixed automatic gas shutoff device for added safety. Not recommended for 180° F sanitizing.

Heavy Gauge Steel Jacket

- Finished with baked enamel over bonderized undercoat

Foam Insulation

- Saves fuel, helps reduce standby heat loss.

Ultra-Low NOx Emissions

- Complies with SCAQMD Rule 1146.2 and other Air Quality Management Districts with similar requirements of 14 ng/J or 20 ppm.

Easy-to-Install

- Completely factory-assembled. Only gas, water and vent connections need to be made. All connections are located in front and top of heaters for ease-of-installation and service.

3-Year Limited Tank and 1-Year Limited Parts Warranty

- For complete warranty information, consult written warranty or go to hotwater.com

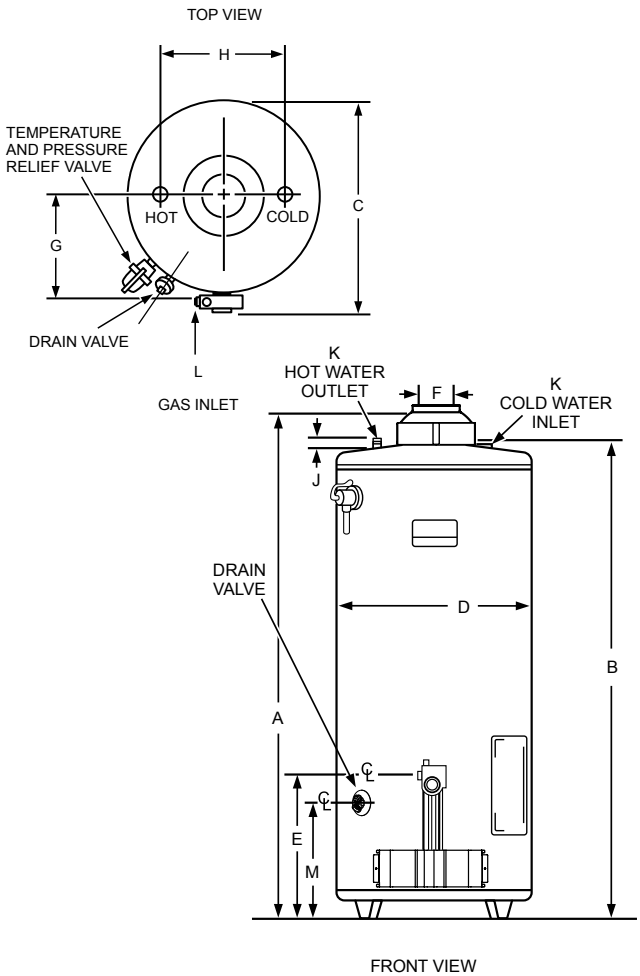

FRONT VIEW

Model Number	Gallon Capacity	Input BTU/hr	Recovery Capacity GPH @ 100°F Rise	Approx. Shipping Weight (lbs)
BL-80 **	74	75,100	73	285
BL-100*	98	75,100	74	350

Dimensions in Inches					
Model Number	A	B	C	D	E
BL-80 **	62-1/16	58	29-1/2	25-1/4	15-7/8
BL-100*	70-1/2	66-1/2	30-15/16	27-3/4	15-3/16

Dimensions in Inches							
Model Number	F	G	H	J	K	L	M
BL-80 **	4	15-1/4	16	2	1	1/2	12-1/2
BL-100*	4	15-3/4	16	1-1/4	1-1/4	1/2	11-15/16

Natural gas only.

*Recovery rating based on 81% thermal efficiency

**Recovery rating based on 80% thermal efficiency

COMMERCIAL GAS

POWER BURNER LIGHT DUTY



Power Gas Burner

- Electronic flame safeguard control with direct spark ignition
- Redundant gas valves for added safety
- Power gas burner requires 120V, 60Hz service
- Non-forced-draft burner; negative draft required in vent piping

Fully Automatic Controls with Safety Shutoff

- High temperature limit control (manual reset)
- Dual thermostats for accurate temperature control

Glass Coating

- Exclusive process provides superior protection against corrosion

3-Year Limited Tank and 1-Year Limited Parts Warranty

- For complete warranty information, consult written warranty or go to hotwater.com



Model Number	BTU Input Per Hour	Tank Size
BTP-270(A)	270,000	81
BTP-370(A)	370,000	81

Model Number	GPH or LPH	Recovery Gallons Per Hour Temperature Rise	Maximum Amperes 120V, 60 Hz, 1
		100°	
BTP-270(A)	GPH	262	5
BTP-370(A)	GPH	359	5

** BTP 370 available in Natural Gas only.

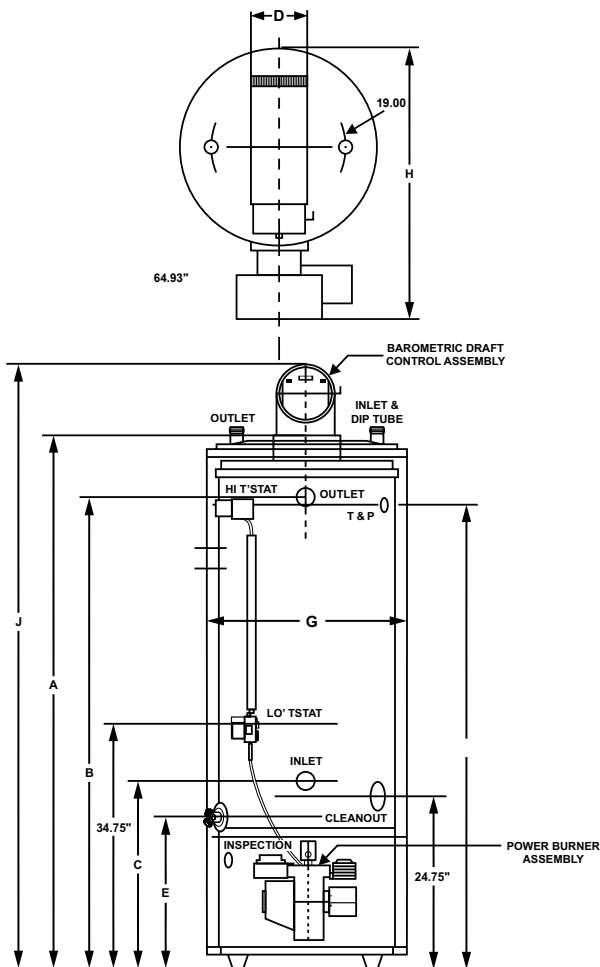

Model Number	Dimensions in Inches				
	A	B	C	D	E
BTP-270(A)	74-3/4	65	26-3/4	6	21-3/8
BTP-370(A)**	74-3/4	65	26-3/4	6	21-3/8

Model Number	Dimensions in Inches			Approx. Shipping Weight	
	G	H	J	Standard	ASME
BTP-270(A)	27-3/4	38	85-1/4	547 lbs	632 lbs
BTP-370(A)**	27-3/4	38	85-1/4	547 lbs	632 lbs

** BTP 370 available in Natural Gas only.

COMMERCIAL GAS

LOW NO_x POWER BURNER



Venting Options

- BTP models designed for conventional atmospheric vertical venting. Barometric draft regulating damper provided. Order Vent Kit Part #100125540.
- BTPV models designed for horizontal atmospheric sidewall venting or direct venting.
- For sidewall venting order Vent Kit Part #100125500.
- For direct venting order Vent Kit Part #100131270.

Low NO_x Power Gas Burner (Natural Gas Only)

- Pre-mix design with internal Flue Gas Recirculation (FGR)
- Safety features include internal blocked flue sensor, separate pilot system, internal thermal cutoff and anti-flashback barrier.

Fully Automatic Controls

- Including safety shut-off, high-temperature limit control
- Dual thermostat, adjust from 120°F to 180°F
- Factory start-up included; required for activating and assuring maximum performance.

3-Year Limited Tank and 1-Year Limited Parts Warranty

- For complete warranty information, consult written warranty or go to hotwater.com



Model Number	Gallon Capacity	Input/BTU/HR Natural Gas	Recovery Capacity GPH @ 100°F Rise	Approx. Shipping Weight (lbs)
BTP(V)-540A	85	540,000	523	950
BTP(V)-650A	85	650,000	630	950
BTP(V)-740A	85	740,000	718	950

Not available in propane (LP).

Vent Kit included in unit price if ordered with heater.

Authorizes start-up service included; required to activate warranty. Consult local factory representative (Continental U.S. only)

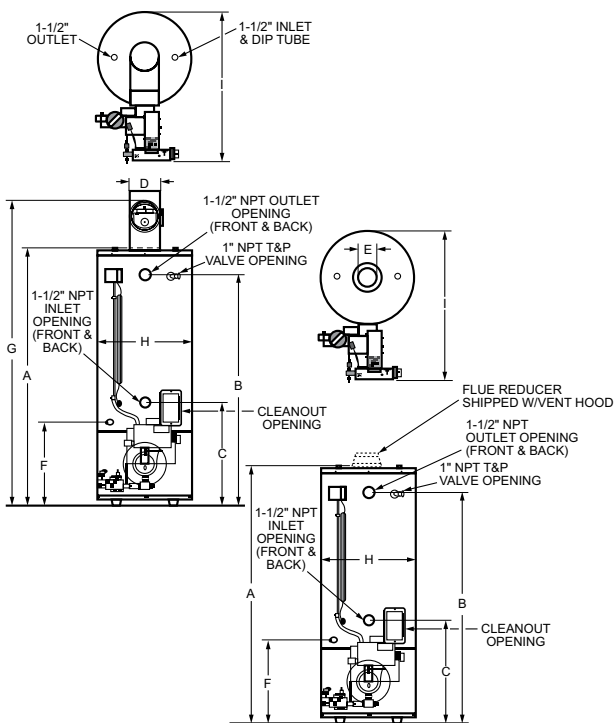

Model Number	Dimensions in Inches				
	A	B	C	D	E
BTP(V)-540A	80-3/4	73	32-1/4	9	26-1/2
BTP(V)-650A	80-3/4	73	32-1/4	9	26-1/2
BTP(V)-740A	80-3/4	73	32-1/4	9	26-1/2

Model Number	Dimensions in Inches			
	F	G	H	I
BTP(V)-540A	26-1/2	93	29-1/2	48-1/2
BTP(V)-650A	26-1/2	93	29-1/2	48-1/2
BTP(V)-740A	26-1/2	93	29-1/2	48-1/2

Not available in propane (LP).

Vent Kit included in unit price if ordered with heater.

Authorizes start-up service included; required to activate warranty. Consult local factory representative (Continental U.S. only)

COMMERCIAL GAS

CONSERVATIONIST® HIGH VOLUME POWER BURNER



Power Gas Burner

- Suitable for natural or propane gas
- Electronic flame safeguard control with intermittent spark ignition
- Main and pilot automatic gas valves with gas pressure regulators
- Diaphragm air switch for proof of blower operation
- Flame inspection port
- Low NOx available on models from 400,000 Btu to 2,000,000 BTU (Natural gas only)
- Factory start-up included. Required for activating and assuring maximum performance.

Fully Automatic Controls with Safety Shutoff

- High-temperature limit control (manual reset)
- CSA certified and ASME rated T&P relief valve
- Hinged-door control compartment
- Standard control is for 120°-180°F water service
- Factory-installed low-water cutoff

Blue Diamond® Glass Coating

- Provides superior corrosion resistance compared to the industry-standard glasslining.

Codes and Standards

- Design-certified by UL (Underwriters Laboratories), according to ANSI Z21. 10.3-4.3 CSA Standards
- Meets the thermal efficiency and standby loss requirements of the U.S. Department of Energy and current edition of ASHRAE/IES 90.1

3-Year Limited Tank and 1-Year Limited Parts Warranty

- For complete warranty information, consult written warranty or go to hotwater.com



Model Number	Gallon Capacity	Recovery Capacity GPH @ 100°F Rise	Input BTU/HR *Natural Gas	Approx. Shipping Weight (lbs)
BTP-150-140	163	136	140,000	1292
BTP-150-199	163	193	199,000	1292
BTP-150-255	163	247	255,000	1292
BTP-150-270	163	262	270,000	1397
BTP-150-400	151	387	400,000	1397
BTP-150-540	151	524	540,000	1505
BTP-150-720	145	698	720,000	1510
BTP-200-300	221	291	300,000	2098
BTP-200-600	221	582	600,000	2098
BTP-200-800	221	776	800,000	2103
BTP-200-1000	221	970	1,000,000	2103
BTP-200-1250	210	1212	1,250,000	2467
BTP-200-1500	201	1454	1,500,000	2757
BTP-300-300	300	291	300,000	2150
BTP-300-600	300	582	600,000	2150
BTP-300-800	411	776	800,000	2308
BTP-300-1000	411	970	1,000,000	2308
BTP-300-1250	411	1212	1,250,000	2584
BTP-300-1500	411	1454	1,500,000	2774
BTP-400-600	411	582	600,000	3207
BTP-400-800	411	776	800,000	3212
BTP-400-1000	411	970	1,000,000	3212
BTP-400-1250	411	1212	1,250,000	3212
BTP-400-1500	411	1455	1,500,000	3402
BTP-400-1750	404	1697	1,750,000	3528
BTP-400-2000	397	1939	2,000,000	3669
BTP-600-720	594	698	720,000	3667
BTP-600-1000	594	970	1,000,000	3667
BTP-600-1250	594	1212	1,250,000	3667
BTP-600-1500	594	1454	1,500,000	3837
BTP-600-1750	594	1697	1,750,000	3837
BTP-600-2000	594	1939	2,000,000	3837
BTP-600-2250	585	2182	2,250,000	4477
BTP-600-2500	575	2424	2,500,000	4619

†Models are available in low NOx (include the "N" in the model number when ordering)
 Exp, BTPN-600-1500 - Natural Gas only.
 Specify when ordering propane (LP) gas.
 Authorized start-up service included; required to activate warranty. Consult local factory representative (Continental U.S. Only).

Line drawings and dimensions on the following page.

COMMERCIAL GAS CONSERVATIONIST® HIGH VOLUME POWER BURNER (CONTINUED)

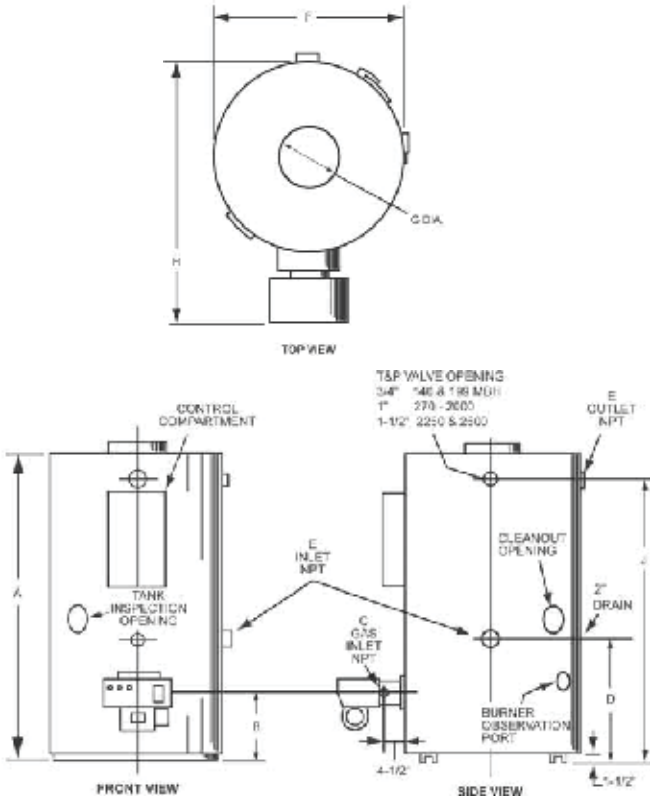

Optional Low Nox Burners		VTPN/NMP Motor HP
Available Low Nox Burner BTU Input Sizes (Nat. Gas Only)	BTUH	
	400,000	1/4 HP
	540,000	
	600,000	
	720,000	
	800,000	1/2 HP
	1,000,000	
	1,250,000	
	1,500,000	1 HP
	1,750,000	
2,000,000		

Model Number	Dimensions in Inches								
	A	B	C	D	E	F	G	H	J
BTP-150-140	82-1/4	13-1/2	1/2	29-1/4	1-1/4	36-1/2	5	47	73-1/2
BTP-150-199	82-1/4	13-1/2	1/2	29-1/4	1-1/4	36-1/2	6	47	73-1/2
BTP-150-255	82-1/4	13-1/2	1/2	29-1/4	1-1/4	36-1/2	6	47	73-1/2
BTP-150-270	82-1/4	13-1/2	1	29-1/4	1-1/4	36-1/2	6	57-1/2	73-1/2
BTP-150-400	82-1/4	13-1/2	1	29-1/4	1-1/4	36-1/2	7	57-1/2	73-1/2
BTP-150-540	82-1/4	13-1/2	1	29-1/4	1-1/4	36-1/2	8	57-1/2	73-1/2
BTP-150-720	82-1/4	13-1/2	1-1/4	29-1/4	1-1/4	36-1/2	10	57-1/2	73-1/2
BTP-200-300	84-1/2	17-1/2	1	34-3/4	1-1/2	44-3/4	6	66-1/2	74-3/4
BTP-200-600	84-1/2	17-1/2	1	34-3/4	1-1/2	44-3/4	8	66-1/2	74-3/4
BTP-200-800	84-1/2	17-1/2	1-1/4	34-3/4	1-1/2	44-3/4	10	66-1/2	74-3/4
BTP-200-1000	84-1/2	17-1/2	1-1/4	34-3/4	1-1/2	44-3/4	10	66-1/2	74-3/4
BTP-200-1250	84-3/4	13-1/2	1-1/4	29-1/2	1-1/2	44-3/4	12	66-1/2	75
BTP-200-1500	84-3/4	13-1/2	1-1/2	29-1/2	1-1/2	44-3/4	12	81-1/2	75
BTP-300-300	92	14	1	29-1/4	1-1/2	44-3/4	6	66-1/2	82-1/2
BTP-300-600	92	14	1	29-1/4	1-1/2	44-3/4	8	66-1/2	81-1/2
BTP-300-800	92	14	1-1/4	29-1/4	1-1/2	44-3/4	10	66-1/2	81-1/2
BTP-300-1000	92	14	1-1/4	29-1/4	1-1/2	44-3/4	10	66-1/2	81-1/2
BTP-300-1250	92	14	1-1/4	29-1/4	1-1/2	44-3/4	12	66-1/2	81-1/2
BTP-300-1500	92	14	1-1/2	29-1/4	1-1/2	44-3/4	12	81-1/2	81-1/2
BTP-400-600	89	17-1/2	1	33-1/4	2	55	8	76-1/2	78-3/4
BTP-400-800	89	17-1/2	1-1/4	33-1/4	2	55	10	76-1/2	78-3/4
BTP-400-1000	89	17-1/2	1-1/4	33-1/4	2	55	10	76-1/2	78-3/4
BTP-400-1250	89	17-1/2	1-1/4	33-1/4	2	55	12	76-1/2	78-3/4
BTP-400-1500	89	17-1/2	1-1/2	33-1/4	2	55	12	91-1/2	78-3/4
BTP-400-1750	89	17-1/2	2	33-1/4	2	55	14	91-1/2	78-3/4
BTP-400-2000	96-1/4	17-1/2	2	33-1/4	2	55	14	91-1/2	86-1/2
BTP-600-720	114	17-1/2	1-1/4	33-1/4	2	55	10	76-1/2	105
BTP-600-1000	114	17-1/2	1-1/4	33-1/4	2	55	10	76-1/2	105
BTP-600-1250	114	17-1/2	1-1/4	33-1/4	2	55	12	76-1/2	105
BTP-600-1500	114	17-1/2	1-1/2	33-1/4	2	55	12	91-1/2	105
BTP-600-1750	114	17-1/2	2	33-1/4	2	55	14	91-1/2	105
BTP-600-2000	114	17-1/2	2	33-1/4	2	55	14	91-1/2	105
BTP-600-2250	114	17-1/2	2	33-1/4	2	55	16	91-1/2	105
BTP-600-2500	114	17-1/2	2	33-1/4	2	55	14	91-1/2	105

†Models are available in low NOx (include the "N" in the model number when ordering)
Exp, BTPN-600-1500 - Natural Gas only.

Specify when ordering propane (LP) gas.

Authorized start-up service included; required to activate warranty. Consult local factory representative (Continental U.S. Only).

CONSERVATIONIST® DURACLAD OIL-FIRED TANK-TYPE



Efficient Combustion Chamber

- Precast, high temperature combustion chamber made of alumina silica ceramic fiber. Engineered for maximum insulation and heat reflection. Unique design assures more complete combustion by stabilizing flame pattern.

Interrupted Ignition

- Reduces electrical consumption

Two Hand-hole Cleanouts

- Allows easy cleaning on standard models COF-385 and larger and ASME models

Easy-to-Install Burner

- Three-bolt mounting of burner assures easy installations.

3-Year Limited Tank and 1-Year Limited Parts Warranty

- Factory Start-Up included: required for activating warranty and assuring maximum operating performance (Continental U.S. only)
- For complete warranty information, consult written warranty or go to hotwater.com



Model Number	Gallon Capacity	Input BTU/HR	Recovery Capacity GPH @ 100° F Rise*	Firing Rate in GPM	Approx. Shipping Weight (lbs)	
					Standard	ASME
COF-199†	86	199,000	191	1.42	553	N/A
COF-245	86	245,000	235	1.75	554	N/A
COF-315	84	315,000	302	2.25	554	657
COF-385	75	385,000	369	2.75	624	742
COF-455	75	455,000	436	3.25	700	747
COF-700	69	700,000	671	5	739	822

*Based on No. 2 fuel oil. All models have 1/8 HP motor.

Add "A" to the end of the model number for ASME tanks. (COF 315A - COF-700A only)

†Model supplied with Flue reducer which should be installed on top cover.

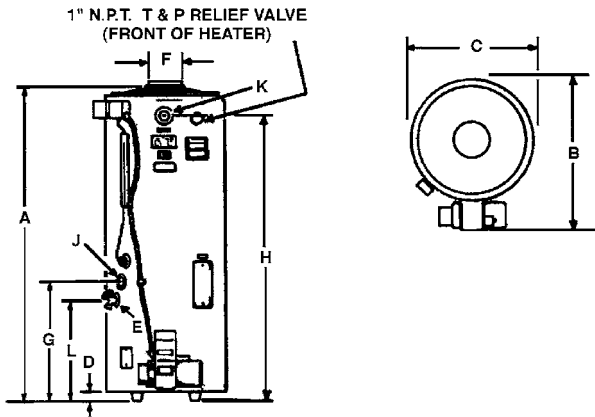

Model Number	Dimensions in Inches				
	A	B	C	D	E
COF-199†	74-1/2	36-3/4	27-3/4	2	3/4 NPT
COF-245	74-1/2	36-3/4	27-3/4	2	3/4 NPT
COF-315A	74-1/2	36-3/4	27-3/4	2	3/4 NPT
COF-385A	73-3/4	36-3/4	27-3/4	2	3/4 NPT
COF-455A	73-3/4	36-3/4	27-3/4	2	3/4 NPT
COF-700A	73-3/4	36-3/4	27-3/4	2	3/4 NPT

Model Number	Dimensions in Inches					
	F	G	H	J	K	L
COF-199†	8	26-5/8	74-1/2	1-1/2 NPT	1-1/2 NPT	22-3/4
COF-245	8	26-5/8	74-1/2	1-1/2 NPT	1-1/2 NPT	22-3/4
COF-315A	8	26-5/8	74-1/2	1-1/2 NPT	1-1/2 NPT	22-3/4
COF-385A	8	24-3/4	73-3/4	1-1/2 NPT	1-1/2 NPT	23-7/16
COF-455A	8	24-3/4	73-3/4	1-1/2 NPT	1-1/2 NPT	23-7/16
COF-700A	8	30-3/16	79-3/16	1-1/2 NPT	1-1/2 NPT	28-7/8

Add "A" to the end of the model number for ASME tanks. (COF 315A - COF-700A only)

†Model supplied with Flue reducer which should be installed on top cover.

CUSTOM HEAVY-DUTY LARGE VOLUME OIL-FIRED



Fully Automatic Controls with Safety Shutoff

- High temperature limit control (manual reset). CSA Certified and ASME rated temperature and pressure relief valve.
- Hinged door control compartment with key lock for ease of access.
- Two thermostats, upper and lower, for accurate temperature control.

Jacket and Insulation

- Heavy gauge steel jacket with baked powder coat finish.
- Insulated with high-density foam insulation that meets or exceed all required standards.
- Meets or exceeds the thermal efficiency and/or standby loss requirements of the U.S.
- Department of Energy and current edition ASHRAE/IES 90.1.

3-Year Limited Tank and 1-Year Limited Parts Warranty

- For complete warranty information, consult written warranty or go to hotwater.com



Model Number	Gallon Capacity	Input Rating BTU/HR	Recovery Capacity GPH @ 100°F Rise
COF-150-140	163	140,000	136
COF-150-199	163	199,000	193
COF-150-255	163	255,000	247
COF-150-270	163	270,000	262
COBT-150-350	150	350,000	339
COF/COBT-150-400	151	400,000	387
COF/COBT-150-540	151	540,000	524
COF/COBT-150-720	145	720,000	698
COF/COBT-200-300*	221	300,000	291
COF/COBT-200-600	221	600,000	582
COF/COBT-200-800	221	800,000	776
COF/COBT-200-1000	201	1,000,000	970
COF/COBT-200-1250	201	1,250,000	1212
COF/COBT-200-1500	201	1,500,000	1455
COF/COBT-300-300*	300	300,000	291
COF/COBT-300-600	300	600,000	582
COF/COBT-300-800	300	800,000	776
COF/COBT-300-1000	300	1,000,000	970
COF/COBT-300-1250	300	1,250,000	1212
COF/COBT-300-1500	300	1,500,000	1455
COF/COBT-400-600	411	600,000	582
COF/COBT-400-800	411	800,000	776
COF/COBT-400-1000	411	1,000,000	970
COF/COBT-400-1250	411	1,250,000	1212
COF/COBT-400-1500	397	1,500,000	1455
COF/COBT-400-1750	397	1,750,000	1697
COF/COBT-400-2000	397	2,000,000	1939
COF/COBT-600-720	594	720,000	698
COF/COBT-600-1000	594	1,000,000	970
COF/COBT-600-1250	594	1,250,000	1212
COF/COBT-600-1500	594	1,500,000	1455
COF/COBT-600-1750	594	1,750,000	1697
COF/COBT-600-2000	594	2,000,000	1939
COF/COBT-600-2250	575	2,250,000	2182
COF/COBT-600-2500	575	2,500,000	2424

*COBT models are 350,000 BTU Natural Gas.
Authorized start-up service included; required to activate warranty.
Consult local factory representative. (Continental U. S. Only).
Specify when ordering propane (LP) gas.

Line drawings and dimensions on the following page.

COMMERCIAL GAS

CUSTOM HEAVY-DUTY LARGE VOLUME OIL-FIRED *(CONTINUED)*

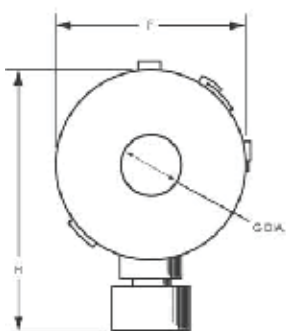

TOP VIEW

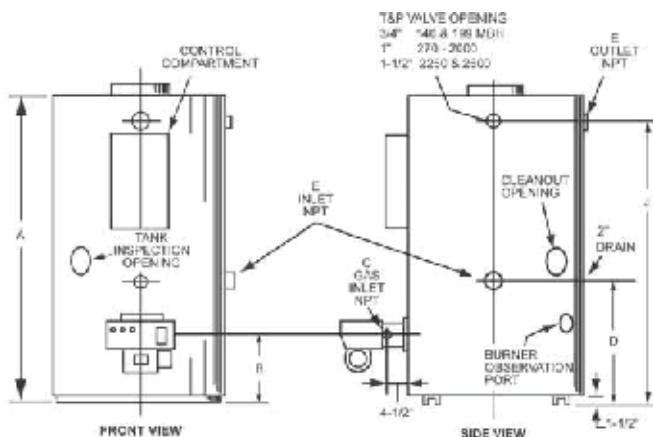

FRONT VIEW

SIDE VIEW

Model Number	Dimensions in Inches								
	A	B	C	D	E	F	G	H	J
COF-150-140	82-1/4	13-1/2	1/2	29-1/4	1-1/4	36-1/2	5	47	73-1/2
COF-150-199	82-1/4	13-1/2	1/2	29-1/4	1-1/4	36-1/2	6	47	73-1/2
COF-150-255	82-1/4	13-1/2	1/2	29-1/4	1-1/4	36-1/2	6	47	73-1/2
COF-150-270	82-1/4	13-1/2	1	29-1/4	1-1/4	36-1/2	6	57-1/2	73-1/2
COBT-150-350	82-1/4	13-1/2	1	29-1/4	1-1/4	36-1/2	7	57-1/2	73-1/2
COF/COBT-150-400	82-1/4	13-1/2	1	29-1/4	1-1/4	36-1/2	7	57-1/2	73-1/2
COF/COBT-150-540	82-1/4	13-1/2	1	29-1/4	1-1/4	36-1/2	8	57-1/2	73-1/2
COF/COBT-150-720	82-1/4	13-1/2	1-1/4	29-1/4	1-1/4	36-1/2	10	57-1/2	73-1/2
COF/COBT-200-300*	84-1/2	17-1/2	1	34-3/4	1-1/2	44-3/4	6	66-1/2	74-3/4
COF/COBT-200-600	84-1/2	17-1/2	1	34-3/4	1-1/2	44-3/4	8	66-1/2	74-3/4
COF/COBT-200-800	84-1/2	17-1/2	1-1/4	34-3/4	1-1/2	44-3/4	10	66-1/2	74-3/4
COF/COBT-200-1000	84-1/2	17-1/2	1-1/4	34-3/4	1-1/2	44-3/4	10	66-1/2	74-3/4
COF/COBT-200-1250	84-3/4	13-1/2	1-1/4	29-1/2	1-1/2	44-3/4	12	66-1/2	75
COF/COBT-200-1500	84-3/4	13-1/1	1-1/4	29-1/2	1-1/2	44-3/4	12	81-1/2	75
COF/COBT-300-300*	92	14	1	29-1/4	1-1/2	44-3/4	6	66-1/2	81-1/2
COF/COBT-300-600	92	14	1	29-1/4	1-1/2	44-3/4	8	66-1/2	81-1/2
COF/COBT-300-800	92	14	1-1/4	29-1/4	1-1/2	44-3/4	10	66-1/2	81-1/2
COF/COBT-300-1000	92	14	1-1/4	29-1/4	1-1/2	44-3/4	10	66-1/2	81-1/2
COF/COBT-300-1250	92	14	1-1/4	29-1/4	1-1/2	44-3/4	12	66-1/2	81-1/2
COF/COBT-300-1500	92	14	1-1/4	29-1/4	1-1/2	44-3/4	12	81-1/2	81-1/2
COF/COBT-400-600	89	17-1/2	1	33-1/4	2	55	8	76-1/2	78-3/4
COF/COBT-400-800	89	17-1/2	1-1/4	33-1/4	2	55	10	76-1/2	78-3/4
COF/COBT-400-1000	89	17-1/2	1-1/4	33-1/4	2	55	10	76-1/2	78-3/4
COF/COBT-400-1250	89	17-1/2	1-1/4	33-1/4	2	55	12	76-1/2	78-3/4
COF/COBT-400-1500	89	17-1/2	1-1/4	33-1/4	2	55	12	91-1/2	78-3/4
COF/COBT-400-1750	89	17-1/2	2	33-1/4	2	55	14	91-1/2	78-3/4
COF/COBT-400-2000	96-1/4	17-1/2	2	33-1/4	2	55	14	91-1/2	86-1/2
COF/COBT-600-720	114	17-1/2	1-1/4	33-1/4	2	55	10	76-1/2	108
COF/COBT-600-1000	114	17-1/2	1-1/4	33-1/4	2	55	10	76-1/2	105
COF/COBT-600-1250	114	17-1/2	1-1/4	33-1/4	2	55	12	76-1/2	105
COF/COBT-600-1500	114	17-1/2	1-1/2	33-1/4	2	55	12	91-1/2	105
COF/COBT-600-1750	114	17-1/2	2	33-1/4	2	55	14	91-1/2	105
COF/COBT-600-2000	114	17-1/2	2	33-1/4	2	55	14	91-1/2	105
COF/COBT-600-2250	114	17-1/2	2	33-1/4	2	55	16	91-1/2	105
COF/COBT-600-2500	114	17-1/2	2	33-1/4	2	55	16	91-1/2	105

*COBT models are 350,000 BTU Natural Gas.

Authorized start-up service included-required to activate warranty.

Consult local factory representative. (Continental U. S. Only).

Specify when ordering propane (LP) gas.

COMMERCIAL ELECTRIC LIGHT-SERVICE



Designed for light duty commercial applications with intermittent hot water loads.

Glasslined Tank

- Tank interior is coated with glass specially designed by A. O. Smith for water heater use.

Heating Elements

- Two 4.5 KW zinc plated copper sheathed elements are standard.

Standard Voltages

- The standard voltage is 240V single phase.

Top Mounted Recessed Junction Box

Controls

- Thermostat is adjustable through a range of 120° to 181°F with a manual reset high temperature cutoff. The heater is wired for non-simultaneous single phase operation.

Coregard™ Anode Rod

- Our anode rods have a stainless steel core that extends the life of the anode rod allowing superior tank protection for longer than standard anode rods.

Enhanced-Flow Brass Drain Valve

- Solid brass, tamper resistant, enhanced-flow, ball type, drain valve.

Maximum Working Pressure 150 psi

Factory Installed CSA Certified and ASME Rated Temperature and Pressure Relief Valve

Certified to UL 1453 for Commercial Electric Water Heaters

Compliance

- Meets the standby loss requirements of the U.S. Department of Energy and current edition of ASHRAE/IES 90.1.

Warranty

- 3-Year limited tank/1-Year limited parts.
- For complete information consult the written warranty or hotwater.com.

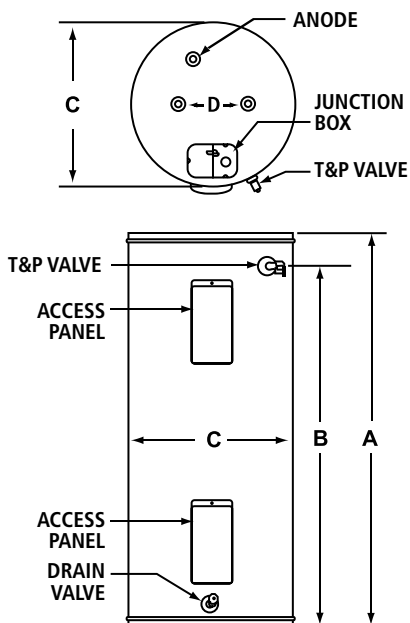

Model Number	Gallon Capacity	Standard Element Wattage 240 VAC	Dimensions in Inches				Approx. Shipping Weight (lbs)
			A	B	C Diameter	D	
LTE 66D	66	4500	60-1/4	53	22	8	146
LTE 80D	80	4500	60-1/2	52-1/4	24	8	175
LTE 120D	119	4500	61-1/2	54-1/2	28	8	268

Not available with top mounted T&P valve option

Element Wattage (Upper/Lower)	U. S. Gallons/Hr at Temperature Rise Indicated	
	F°	100
Non-Simultaneous Operation		
/1500	GPH	6
/2000	GPH	8
/2500	GPH	10
3000/3000	GPH	12
4000/4000	GPH	16
4500/4500	GPH	18
5000/5000	GPH	20
6000/6000	GPH	24
Simultaneous Operation		
3000/3000	GPH	24
4000/4000	GPH	32
4500/4500	GPH	36
5000/5000	GPH	41
6000/6000	GPH	49

COMMERCIAL ELECTRIC

DEN/DEL ELECTRIC DURA-POWER™



DEN-40

DEL-30



Low Lead Content



Glasslined Tank

- Thirteen sizes, 6 thru 119 gallon capacity.
- Tank interior is coated with glass specially designed by A. O. Smith for water heater use.

Elements

- Zinc plated copper sheaths for longer life.
- Medium watt density means lower surface temperature to minimize scale build-up and more surface to heat water. Element sizes from 1.5 to 6 KW. Maximum input 12 KW

Standard Voltages

- 120, 277 single phase and 208, 240 and 480V unbalanced three-phase delta; easily converted to single-phase at terminal block (except 208V with 6000 watt elements). Single element heater, single-phase only.

Terminal Block

- Factory-installed. Just bring the service to heater and connect to block. Terminal block not supplied on 120V & 277 volt models. (No junction box on DEL6-20)

Element Wattage (Upper/Lower)	U. S. Gallons/Hr at Temperature Rise Indicated	
	F°	100
Non-Simultaneous Operation		
/1500	GPH	6
/2000	GPH	8
/2500	GPH	10
3000/3000	GPH	12
4000/4000	GPH	16
4500/4500	GPH	18
5000/5000	GPH	20
6000/6000	GPH	24
Simultaneous Operation		
3000/3000	GPH	24
4000/4000	GPH	32
4500/4500	GPH	36
5000/5000	GPH	41
6000/6000	GPH	49

6 gallon model not available above 3.0 kW.

Single element heaters available in single phase only.

HOT WATER OUTLET DEL-6

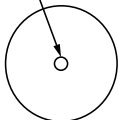
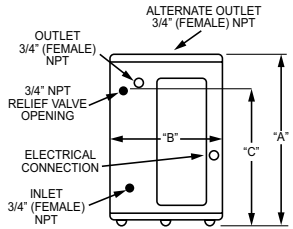
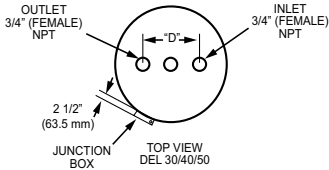
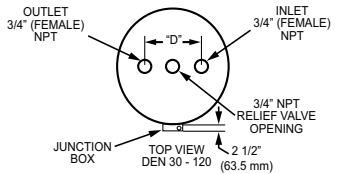
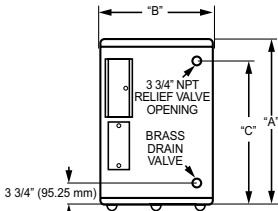
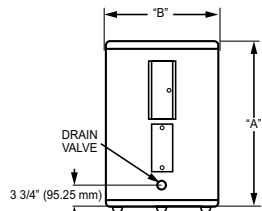
TOP VIEW
DEL 6/10/15/20FRONT VIEW
DEL 6/10/15/20
*(NO SIDE OUTLET AVAILABLE FOR DEL-6 MODELS)TOP VIEW
DEL 30/40/50TOP VIEW
DEN 30-120FRONT VIEW
DEL 30/40/50FRONT VIEW
DEN 30-120

Model Number	Gallon Capacity	Dimensions in Inches				Approx. Shipping Weight (lbs.)
		A	B	C	D	
Compact Models						
DEL-6S	6	15-1/2	14-1/4	11	N/A	35
DEL-10S	10	18-1/4	18	12-1/2	N/A	54
DEL-15S	15	26	18	20-1/2	N/A	58
DEL-20S	20	22-1/4	21-3/4	15-3/8	N/A	73
Lowboy Models						
DEL-30D	30	30-7/8	21-3/4	24-1/8	8	100
DEL-40D	40	32-1/4	24	25-9/16	8	125
DEL-50D	50	32-1/4	26-1/2	25-1/8	8	166
Tall Models						
DEN-30D	30	34-1/2	20-1/2	N/A	8	98
DEN-40D	40	45-1/8	20-1/2	N/A	8	113
DEN-52D	50	54-7/8	20-1/2	N/A	8	131
DEN-66D	66	60-3/4	21-3/4	N/A	8	176
DEN-80D	80	59-3/8	24	N/A	8	211
DEN-120D	119	62-7/16	29-3/8	N/A	8	326

S= Single Element D= Dual Elements.

Dual element models wired for 3-phase 208/240/480 volt.

Field convertible to 1-phase as long as amp does not exceed 48 Amps.

COMMERCIAL ELECTRIC GOLD Xi SERIES



Advanced Electronic Control

- Plain English text and animated icons display diagnostics

Economy Mode Operation Lowers the Operating Set Point and Reduces Operating Costs

Thermostatic Linear Sequencing Control Helps Reduce Current Surges and Provides Accurate Control of Water Temperature

Goldenrod Elements

- All DVE models ship standard with patented Goldenrod 24K gold plated elements. Goldenrod elements provide long life with superior scaling resistance.

Standard Voltages

- 208, 240, 277, 480V single-phase and three-phase delta. Convertible from three-phase to single-phase (in field) and vice versa (except 208/54kW) 277 single-phase only.

Element availability

- DRE/DVE heaters available from 3kw to 54 KW with recoveries of 25 to 837 GPH at a 100°F rise.

3-Year Limited Tank and 1-Year Limited Parts Warranty

- For complete warranty information, consult written warranty or go to hotwater.com.



ASME/CRN
(optional)



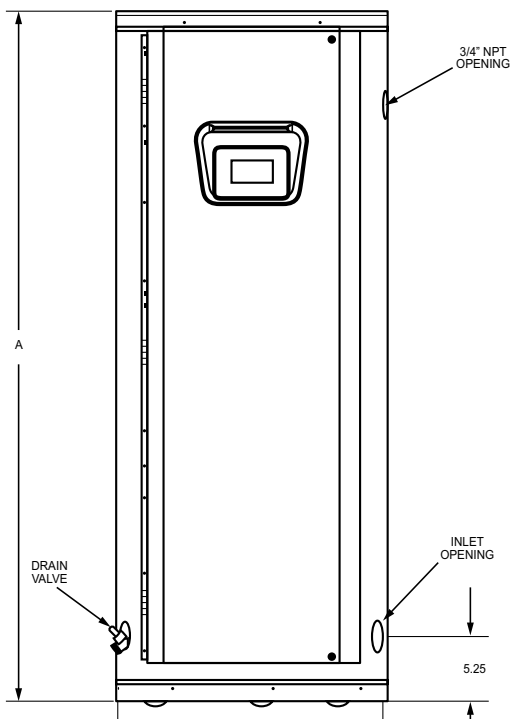
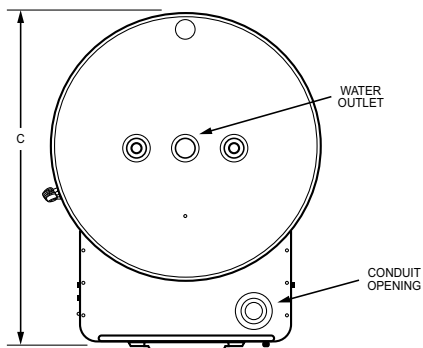

Model Number	Gallon Capacity	Dimensions in Inches			Approx. Shipping Weight (lbs)
		A	B	C	
DVE-52	50	55-3/4	21-3/4	27	265
DVE-80	80	60-1/4	25-1/2	31	280
DVE-120	119	62-1/4	29-1/2	35	390

See specification sheets or contact your local rep for optional kW's available.

COMMERCIAL ELECTRIC

GOLD SERIES



Gold Elements

- DRE models ship with the Goldenrod 24K gold plated elements (see spec sheet for kW options).
- Patented Goldenrod elements provide long life and superior scaling resistance.
- Low watt density means lower surface temperature to minimize scale buildup and more surface to heat water. Goldenrod elements carry a one-year warranty against failure due to lime scale buildup.

Fusing

- Protects all elements, thermostats, and internal wiring circuits against excess current flow. Meets National Electrical Code requirements that non-ASME tanks must have internal fusing when current draw exceeds 48 amps. Available as an option on Canadian-built heaters

Meets the Standby Loss Requirements of the U. S. Department of Energy and Current Edition of AHRAE/IES 90.1.

Standard Voltages

- 208, 240, 277, 480V single-phase and three-phase delta. Convertible from three-phase to single-phase (in field) and vice versa (except 208/54kW) 277 single-phase only.

Element availability

- DRE/DVE heaters available from 3kw to 54 KW with recoveries of 25 to 837 GPH at a 100°F rise.

3-Year Limited Tank and 1-Year Limited Parts Warranty

- For complete warranty information, consult written warranty or go to hotwater.com.



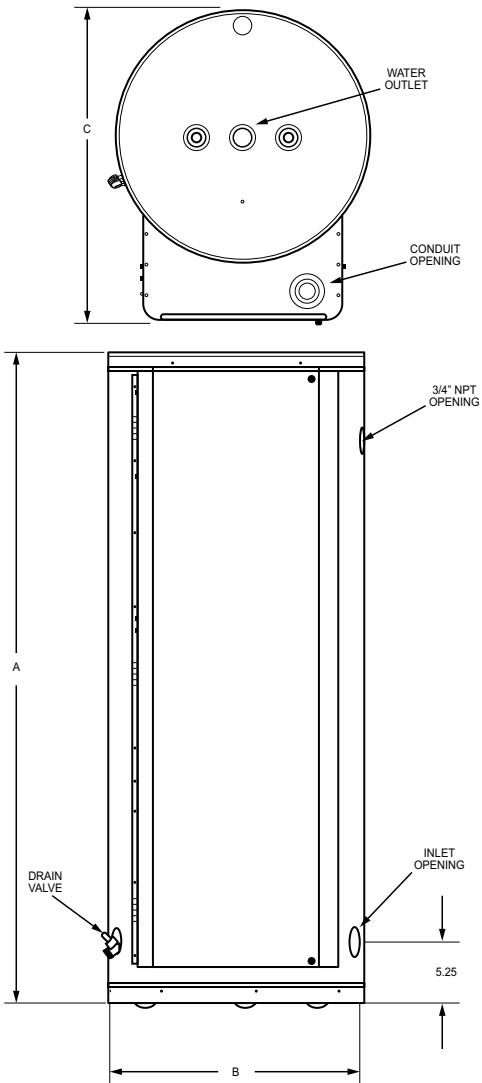

Model Number	Gallon Capacity	Dimensions in Inches			Approx. Shipping Weight (lbs)
		A	B	C	
DRE-52*	50	55-3/4	21-3/4	27	265
DRE-80	80	60-1/4	25-1/2	31	280
DRE-120	119	62-1/4	29-1/2	35	390

* DRE-52 is maximum 36kW.

See specification sheets or contact your local rep for optional kW's available.

COMMERCIAL ELECTRIC HEAVY-DUTY CUSTOM Xi



Advanced Electronic Control

- Provides Precise Temperature Control and Plain English Text with Animated Icons Display

Low-Water Cutoff—Remote Electronic Immersion-Type Probe to Prevent Energizing of the Elements, Eliminating Accidental Dry Firing

Incoloy-Sheath Heating Elements Standard

Factory-Wired, 120V Circuit Controls

Power-Circuit Fusing for System Protection

Glass-Lined Tank, with ASME Construction

CSA Certified and ASME Rated T&P Relief Valve

BACnet and Modbus Compatible with ICC Interface

3-Year Limited Tank and 1-Year Limited Parts Warranty

- For complete warranty information, consult written warranty or go to hotwater.com

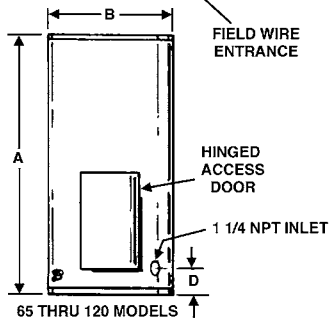
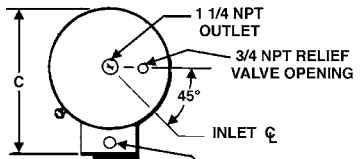
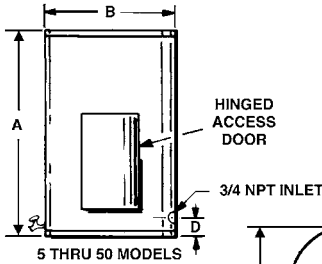
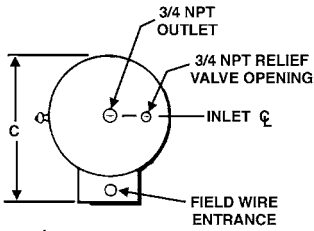

Model Number	Gallon Capacity	Maximum kW Input	Dimensions in Inches (mm)				Approx. Shipping Weight (lbs.)
			A	B	C	D	
DSE-5	5	3	20-1/4	16-1/4	22-1/2	5-1/4	82
DSE-10	10	6	26-1/4	18-3/4	25	5-1/4	116
DSE-20	20	18	27-1/4	20-1/2	26-1/2	5-3/4	145
DSE-30	30	24	35-3/4	20-1/2	26-1/2	5-3/4	150
DSE-40	40	36	45-3/4	20-1/2	26-1/2	5-3/4	190
DSE-50	50	90	54-3/4	20-1/2	26-1/2	5-3/4	221
DSE-65	65	90	54	26-1/2	33-1/2	7	280
DSE-80	80	90	52-1/4	28	35	7	285
DSE-100	100	90	60-1/2	28	35	7	354
DSE-120	120	90	65-1/2	30	37	7-1/2	420

COMMERCIAL ELECTRIC

HEAVY-DUTY CMC/SU BOOSTER

ELECTRIC DURA-POWER™



Incoloy-Sheath Heating Elements
Standard

A. O. Smith Goldenrod® Elements
Optional

Standard Voltages for Easy Installation

Immersion Thermostat for Efficient
Control

Power-Circuit Fusing for System
Protection

Heavy-Duty Magnetic Contactors

CMC Available in 6 to 54 KW Inputs
and 25 to 221 GPH Recovery at 100°F

SU Available in 24 to 54 KW Inputs and
98 to 221 GPH Recovery at 100°F

CMC Model is Under-Counter
Mountable

Standard Voltages: 208, 240, 277, 480

Factory-Wired 120V Circuit Controls

3-Year Limited Warranty

SU MODELS

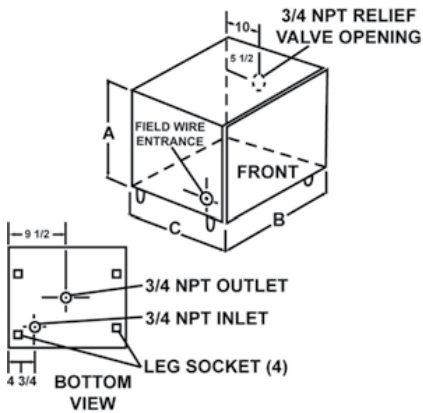

CMC MODELS

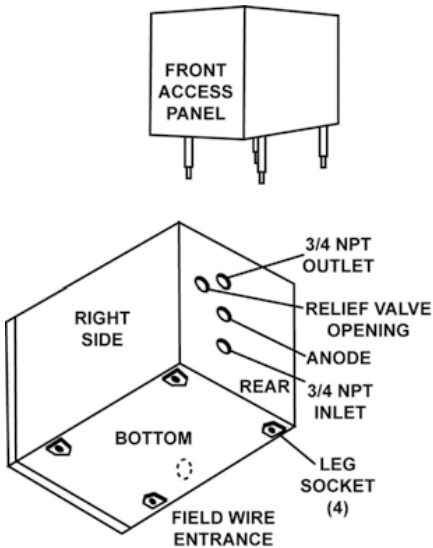

Model Number	Gallon Capacity	Dimensions in Inches			Inlet/Outlet	Approx. Shipping Weight (lbs)
		A	B	C		
CMC-6 through CMC-18	5	13.75	13	23.5	3/4	80
CMC-20 through CMC-54	5	12	18	23.5	3/4	96
SU-24 through SU-54	20	25	22.25	23	3/4	200

COMMERCIAL ELECTRIC

HEAVY-DUTY PREMIUM ELECTRIC

DVE/DHE DURA-POWER™



Advanced Electronic Control: A. O. Smith's New Proprietary Electronic Water Heater Control Provides Precise $\pm 1^\circ\text{F}$ Temperature Control that is Ideal for Industrial and Food Service Applications where Exact Temperatures of Hot Water are Needed.

iCOMM™ Compatible and Can be Monitored from Remote Locations; Call 1.888.WATER02 for More Information.

Progressive Modulating: Sizes the Input of Available Elements to Match Current Load Conditions; Rotates and Lead Lags Element Loads to Provide Long Life and Equal Wear.



ASME

Heavy-Duty Incoloy-Sheath Heating Elements

240V, 480V and 600V

Check with Factory for Voltages and kW's Not Listed.

Factory-Installed Terminal Block

Heavy-Duty Magnetic Contactors

Factory-Wired, 120V Circuit Controls

Power-Circuit Fusing

Low-Water Cutoff

Glass-Lined Tank (Standard)

Handhole Clean-Out(s)

Color-Coded Circuitry

CSA Certified and ASME Rated T&P Relief Valve

Standard kW Ratings	Number of Immersion Heaters	BTU Input and Output	Recovery Capacity GPH @ 100°F Rise	Standard kW Ratings	Number of Immersion Heaters	BTU Input and Output	Recovery Capacity GPH @ 100°F Rise
24	2-12kW	81,912	98	600	40-15kW	2,047,800	2,460
30	2-15kW	102,390	123	630	42-15kW	2,150,190	2,583
36	3-12kW	122,868	147	660	44-15kW	2,252,580	2,706
45	3-15kW	153,585	184	690	46-15kW	2,345,970	2,829
60	4-15kW	204,720	246	720	48-15kW	2,457,360	2,952
75	5-15kW	255,975	307	810	54-15kW	2,764,530	3,321
90	6-15kW	307,170	369	900	60-15kW	3,071,700	3,690
105	7-15kW	358,365	430	990	66-15kW	3,378,870	4,059
120	8-15kW	409,560	492	1080	72-15kW	3,686,040	4,428
150	10-15kW	511,950	615	1170	78-15kW	3,993,210	4,797
180	12-15kW	614,340	738	1260	84-15kW	4,300,380	5,166
210	14-15kW	716,730	861	1350	90-15kW	4,607,550	5,535
240	16-15kW	819,120	987	1440	96-15kW	4,914,720	5,904
270	18-15kW	921,510	1,107	1530	102-15kW	5,221,890	6,273
300	20-15kW	1,023,900	1,230	1620	108-15kW	5,529,060	6,642
330	22-15kW	1,126,290	1,353	1800	120-15kW	6,141,600	7,380
360	24-15kW	1,228,680	1,476	1980	132-15kW	6,757,740	8,118
390	26-15kW	1,331,070	1,599	2040	136-15kW	6,962,520	8,364
420	28-15kW	1,433,460	1,722	2220	148-15kW	7,576,860	9,102
450	30-15kW	1,535,850	1,845	2250	150-15kW	7,679,250	9,225
480	32-15kW	1,638,240	1,968	2400	160-15kW	8,188,800	9,840
510	34-15kW	1,740,630	2,091	2540	176-15kW	9,010,320	10,824
540	36-15kW	1,843,020	2,214	2820	188-15kW	9,624,660	11,562
570	38-15kW	1,945,410	2,337	3000	200-15kW	10,236,000	12,300

Complete model number includes the desired kw at the end, minimum installation Clearances required: 30" from front, 12" from top and 24" from right side.
BACnet and Modbus connectivity available with the ICC Gateway device.

Line drawings and dimensions on the following page.

COMMERCIAL ELECTRIC

HEAVY-DUTY PREMIUM ELECTRIC

DVE/DHE DURA-POWER™ (CONTINUED)

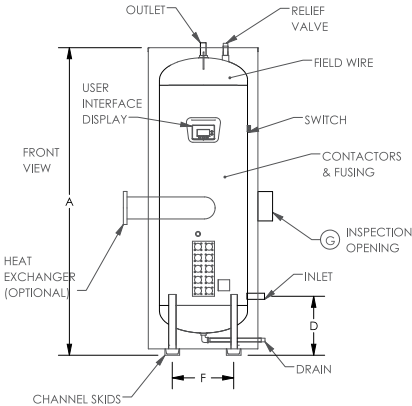
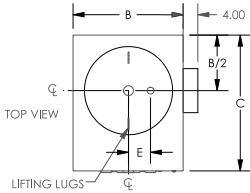
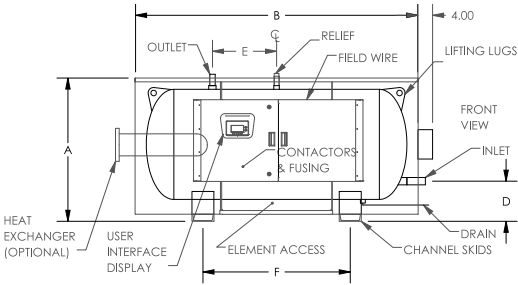
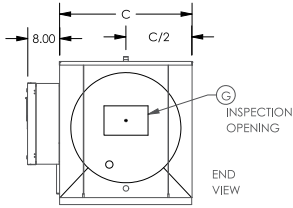

Model Number	Gallon Capacity	Maximum kW Input	Dimensions in Inches					
			A	B	C	D	E	F
Horizontal Electric Storage Heater								
DHE-200	200	180	38-1/2	77	36	10-1/2	17-1/2	31
DHE-250	250	240	38-1/2	91	36	10-1/2	24	48
DHE-300	300	300	44-1/2	81	42	8-1/4	17	36
DHE-350	350	330	44-1/2	93	42	8-1/4	23	48
DHE-400	400	390	44-1/2	100	42	8-1/4	26-1/2	55
DHE-500	500	480	51	94	48	14	24	48
DHE-600	600	600	51	109	48	14	32	64
DHE-700	700	690	51	121	48	14	38	76
DHE-800	800	780	57	111	54	16-1/2	32	64
DHE-1,000	1,000	990	61	111	60	16-1/2	29-1/2	59
DHE-1,250	1,250	1,200	61	138	60	16-1/2	43	86
DHE-1,500	1,500	1,500	61	150	60	16-1/2	50	98
DHE-2,000	2,000	1,980	70	177	66	20	60	120
DHE-3,000	3,000	3,000	76	211	72	20	72-1/2	131
DHE-5,000	5,000	3,000	82	296	78	20-1/2	113-1/2	195
DHE-7,500	7,500	3,000	94	317	90	20-1/2	121	218
DHE-10,000	10,000	3,000	106	345	102	22	132	220
Vertical Electric Storage Heater								
DVE-140	140	150	83-1/2	30	37	16	6	17
DVE-150	150	150	83-1/2	30	37	16	6	17
DVE-150L	150	150	59-1/2	36	43	17-1/2	6	21
DVE-200	200	180	79-1/2	36	43	17-1/2	6	21
DVE-250	250	240	93	36	43	17-1/2	6	21
DVE-300	300	300	83-1/2	42	49	19	6	25-1/2
DVE-350	350	330	95-1/2	42	49	19	6	25-1/2
DVE-400	400	390	102-1/2	42	49	19	6	25-1/2
DVE-500	500	480	97	48	55	21	6	30
DVE-600	600	600	112	48	55	21	6	30
DVE-700	700	690	124	48	55	21	6	30
DVE-800	800	780	116	56	61	23	8	34
DVE-1000	1,000	990	116	60	67	24-1/2	10	38
DVE-1250	1,250	1,200	143	60	67	24-1/2	10	38
DVE-1500	1,500	1,500	155	60	67	24-1/2	10	38
DVE-2000	2,000	1,980	183	66	73	25	12	42-1/2
DVE-3000	3,000	3,000	217	72	79	27-1/2	14	47
DVE-5000	5,000	3,000	309	78	85	30	14	51
DVE-7500	7,500	3,000	330	90	97	30	14	59-1/2
DVE-10,000	10,000	3,000	358	102	109	30	14	68

Complete model number includes the desired kW at the end (example: DVE-140-120)
 Minimum installation clearances required: 30" from front, 12" from top and 24" from right side

150 gallon available in both tall (T) and short (S) models

BACnet and Modbus connectivity available with the ICC Gateway device

CIRCULATING WATER HEATER

XP HIGH EFFICIENCY WATER HEATERS



Up to 96% Thermal Efficiency

Fully Modulating with 5:1 Turndown

Advanced Electronics with Large Touchscreen Display and Built-In Lead/Lag Sequencing

Direct Vent Flexibility Up to 100 Feet

Matches with Storage Tank for Storage Flexibility

ASME Rated Relief Valve

160 lb. ASME Working Pressure

Factory-Supplied Bronze Circulating Pump

Adjustable Pump Delay

316L Stainless steel Heat Exchanger

Professional Start-Up Included: Required for Activating Warranty and Assuring Maximum Operating Performance

Meets the Requirements of South Coast Air Quality Management District in Southern California and the Requirements of Texas Commission on Environmental Qualities.

5-Year Heat Exchanger and 1-Year Parts Limited Warranty

- For complete warranty information, consult written warranty or go to hotwater.com

XP



ASME

Recovery Capacities					
Model Number	BTU/HR Natural Gas Input	Water Flow	Temperature Rise		
			70	100	140
XWH-150	150,000	GPH	248	173	124
XWH-200	200,000	GPH	336	235	168
XWH-285	285,000	GPH	474	332	237
XWH-400	400,000	GPH	665	465	332
XWH-500	500,000	GPH	831	582	416
XWH-600	600,000	GPH	997	698	499
XWH-700	700,000	GPH	1,164	815	582
XWH-800	800,000	GPH	1,330	931	665

Line drawings and dimensions on the following page.

CIRCULATING WATER HEATER

XP HIGH EFFICIENCY WATER HEATERS (CONTINUED)

150 - 200

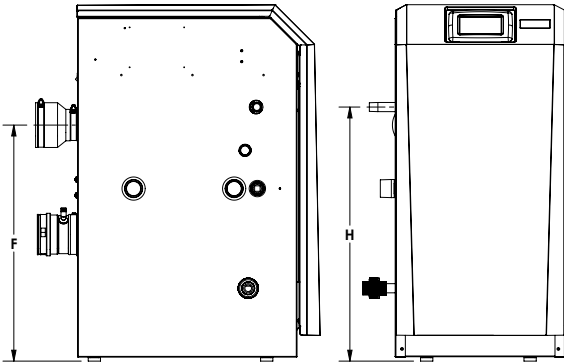

Model Number	Dimensions in Inches			
	A	B	C	D
XWH-150	32-3/4	18-1/4	15-1/2	6-3/4
XWH-200	32-3/4	22-1/4	15-1/2	6-3/4

Model Number	Dimensions in Inches				
	E	F	G	H	I
XWH-150	15-3/4	21-1/2	11-1/2	23-1/4	3-3/4
XWH-200	15-3/4	21-1/2	11-1/2	23-1/4	9-1/4

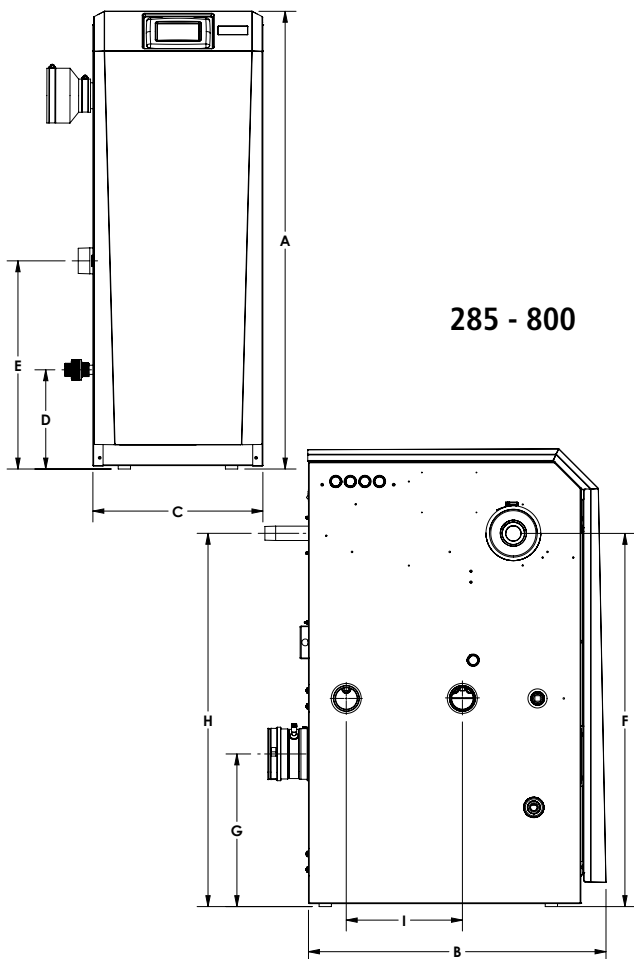

285 - 800

Model Number	Dimensions in Inches				
	A	B	C	D	E
XWH-285	42	20	15-1/2	9-1/4	19-1/4
XWH-400	42	27-1/4	15-1/2	9	19
XWH-500	42	31-3/4	15-1/2	9-1/4	19
XWH-600	42	46-1/2	15-1/2	9-1/4	19-1/4
XWH-700	42	40-1/2	15-1/2	9-1/4	19-1/4
XWH-800	42	45-1/2	15-1/2	9-1/4	19-1/4

Model Number	Dimensions in Inches			
	F	G	H	I
XWH-285	34-1/4	14	31-1/2	3-3/4
XWH-400	34-1/4	14	34-1/4	10-3/4
XWH-500	32-3/4	14	36-1/4	10-3/4
XWH-600	36-1/2	14	33-1/4	10-3/4
XWH-700	36-1/2	14	33-1/4	13-3/4
XWH-800	36-1/2	14	33-1/4	13-3/4

CIRCULATING WATER HEATER

XP^{PLUS} HIGH EFFICIENCY WATER HEATERS



Up to 99% in Low Temperature Applications

Super Alloy Metal Fiber Burners

20:1 Turndown Models 2 Million BTUH and up, 10:1 Turndown Models 1.7 Million BTUH and Down

ASME Rated Relief Valve

160 lb. ASME Working Pressure

Factory-Installed Bronze Circulating Pump

Adjustable Pump Delay

Honeywell Sola Control with Color Touchscreen LCD Display

Multi-Burner Sequencing Models 2 Million BTUH and up Have 4 Burners; Models 1.7 Million BTUH and Down Have 2 Burners

Redundant Flow and Low Water Protection-Factory Installed LWCO and Flow Switch(s)

Manual Reset High Limit

316L Stainless steel Heat Exchanger(s)

Professional Start-Up Included: Required for Activating Warranty and Assuring Maximum Operating Performance

Meets the Requirements of South Coast Air Quality Management District in Southern California and the Requirements of Texas Commission on Environmental Qualities.

5-Year Heat Exchanger and 1-Year Parts Limited Warranty

- For complete warranty information, consult written warranty or go to hotwater.com

XP^{PLUS}



ASME
CRN

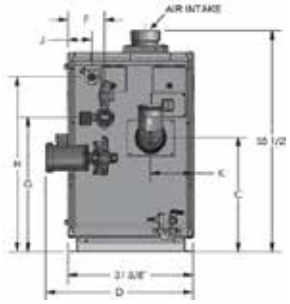
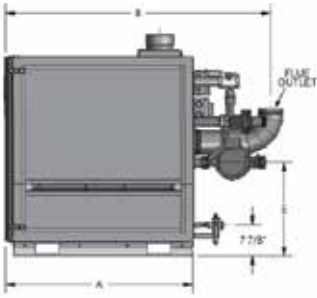

Recovery Capacities			
Model Number	BTU/HR Natural Gas Input	Water Flow	Temperature Rise °F
			100
XWH-1000	920,000	GPH	1,065
XWH-1300	1,300,000	GPH	1,497
XWH-1700	1,700,000	GPH	1,962
XWH-2000	2,000,000	GPH	2,317
XWH-2600	2,600,000	GPH	3,000
XWH-3400	3,400,000	GPH	3,956

Simple Heat Exchanger Model Dimensions			
Models	XWH-1000	XWH-1300	XWH-1700
	Dimensions in Inches		
Flue Outlet Diameter	6	8	8
Air Intake Diameter	6	6	8
Wat Inlet	2 inch NPT		2-1/2 inch NPT
Water Outlet	2 inch NPT		2-1/2 inch NPT
Gas Inlet	2 inch NPT		2 inch NPT
A	47	49	57
B	67	68	76
C	29	29	29
D	37	38	37
E	23	23	24
F	9	9	9
G	34	34	34
H	44	45	45
J	6	6	6
K	11	11	11
L	12	11	12

Line drawings and dimensions on the following page.

CIRCULATING WATER HEATER

XP^{PLUS} HIGH EFFICIENCY WATER HEATERS (CONTINUED)

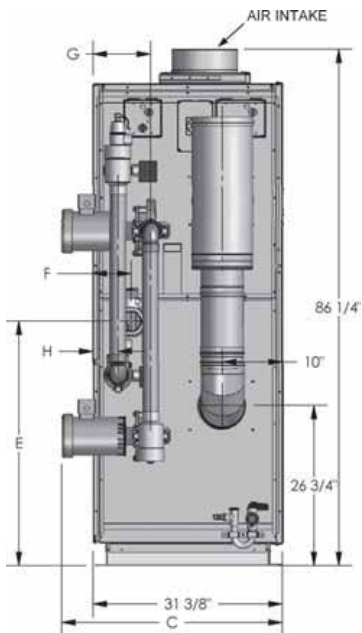
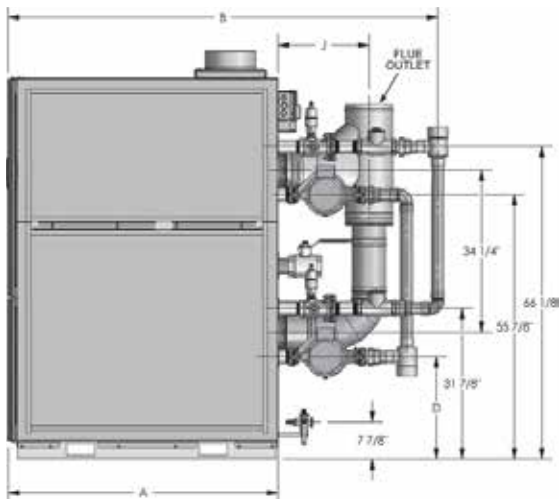

Recovery Capacities			Approx. Shipping Weight (lbs)
Model Number	BTU/HR Natural Gas Input	Recovery Capacity GPH @ 100°F Rise	
XWH-1000	920,000	1,065	865
XWH-1300	1,300,000	1,497	1065
XWH-1700	1,700,000	1,962	1140
XWH-2000	2,000,000	2,317	1485
XWH-2600	2,600,000	3,000	1830
XWH-3400	3,400,000	3,956	2175

Double Heat Exchanger Model Dimensions			
Models	XWH-2000	XWH-2600	XWH-3400
	Dimensions in Inches		
Flue Outlet Diameter	8	8	10
Air Intake Diameter	8	8	10
Wat Inlet	3 inch NPT		4 inch NPT
Water Outlet	3 inch NPT		4 inch NPT
Gas Inlet	2 inch NPT		3 inch NPT
A	47	49	57
B	78	80	91
C	36	37	37
D	22	22	22
E	40	41	41
F	7	6	6
G	10	10	10
H	4	4	4
J	20	19	19
K	12	12	13

COMMERCIAL WATER HEATER

BURKAY® GENESIS® DOMESTIC WATER HEATER

85% Thermal Efficiency

Electronic Control with Precise Temperature Management

Stage Gas Firing System - Prevents Short Cycling and Ensures Smooth Operation, Saves Fuel and Extends Product Life

Low NOx Operation

Copper Finned-Tube Heat Exchanger

Space-Saving Design: Optional Stack Rack Allows One Unit to be Stacked on Top of Another, Doubling Output within the Footprint of a Single Unit

Meets ASHRAE/IES 90.1-2004

Multiple Venting Options

Factory Start-Up Included

5-Year Heat Exchanger and 1-Year Parts Limited Warranty

- For complete warranty information, consult written warranty or go to hotwater.com.



Burkay
GENESIS®



Model Number	Input MBH	Recovery Capacity GPH @ 100°F Rise	Approx. Shipping Weight (lbs)
GWH-400N	399	412	454
GWH-500N	500	515	467
GWH-650N	650	670	551
GWH-750N	750	773	611
GWH-1000N	990	1,020	843
GWH-1250N	1,260	1,298	939
GWH-1450N	1,440	1,484	1,035
GWH-1800N	1,800	1,855	1,168
GWH-2100N	2,070	2,133	1,285

When ordering propane change "N" to "P" in the model number (example GWH-750P).

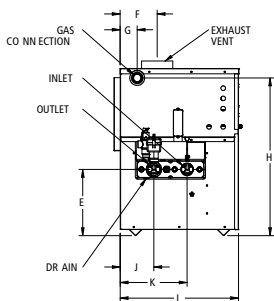

GWH-400 THRU GWH-750

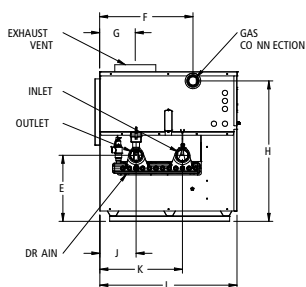

GWH-1000 THRU GWH-2100

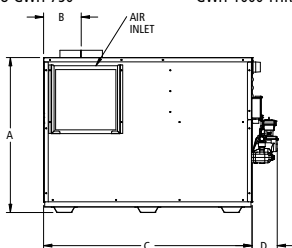

SIDE VIEW

Model Number	Dimensions in Inches					
	A	B	C	D	E	F
GWH-400N	31-1/2	7	37-5/8	8-7/8	12-1/2	7
GWH-500N	31-1/2	7	45-3/8	8-7/8	12-1/2	7
GWH-650N	31-1/2	8-1/2	56-3/4	8-7/8	12-1/2	8-1/2
GWH-750N	31-1/2	8-1/2	64	8-7/8	12-1/2	8-1/2
GWH-1000N	36	8-3/4	48-1/2	5-7/8	15-7/8	22-1/2
GWH-1250N	36	9-3/4	58-3/4	5-7/8	15-7/8	22-1/2
GWH-1450N	36	10-1/2	68-7/8	5-7/8	15-7/8	22-1/2
GWH-1800N	36	11	82-3/8	5-7/8	15-7/8	22-1/2
GWH-2100N	36	11	92-5/8	5-7/8	15-7/8	22-1/2

Model Number	Dimensions in Inches				
	G	H	J	K	L
GWH-400N	3-1/4	29-3/4	6-3/8	12-5/8	22-1/4
GWH-500N	3-1/4	29-3/4	6-3/8	12-5/8	22-1/4
GWH-650N	3-1/4	29-3/4	6-3/8	12-5/8	22-1/4
GWH-750N	3-1/4	29-3/4	6-3/8	12-5/8	22-1/4
GWH-1000N	8-1/2	33-3/4	8-3/4	19-7/8	33
GWH-1250N	9-3/4	33-3/4	8-3/4	19-7/8	33
GWH-1450N	10-1/4	33-3/4	8-3/4	19-7/8	33
GWH-1800N	10-7/8	33-3/4	8-3/4	19-7/8	33
GWH-2100N	10-7/8	33-3/4	8-3/4	19-7/8	33

When ordering propane change "N" to "P" in the model number (example GWH-750P).

COMMERCIAL WATER HEATER

VARIABLE FIRE™ HIGH-EFFICIENCY WATER HEATERS



Up to 85% Thermal Efficiency

Advanced Modulating Control with Venturi-Mixing Gas/Air Ratio System

Small Footprints, Zero Clearance to Combustibles on Sides of Unit

Category II and IV Listed: Requires the use of AL29-4C, a Vent Material That Resists the Effects of Corrosive Condensates

Complies with SCAQMD Rule 1146.2 and Other Air Quality Management Districts with Similar Requirements for Low NOx emissions

Capable of Firing from 100% to 25% (or a 4:1 Turndown Ratio) of the Rated Input, Based on the Current System Demand



Meets Thermal Efficiency and Standby Loss Requirements of the U.S. Department of Energy and Current Edition of ASHRAE/IES 90.1

Professional Start-Up Included - Required for Activating Warranty and Assuring Maximum Operating Performance

5-Year Heat Exchanger and 1-Year Parts Limited Warranty

- For complete warranty information, consult written warranty or go to hotwater.com.

Model Number	BTU/Hr Input	Recovery Capacity GPH @ 100°F Rise	Approx. Shipping Weight (lbs)
VWH0500N	500,001	515	573
VWH0750N	750,000	773	622
VWH1000N	999,999	1030	662
VWH1500N	1,500,000	1545	1,118
VWH2000N	2,000,000	2061	1,187

Change "N" to "P" when ordering propane (LP) gas (Example: VWH-750-P).

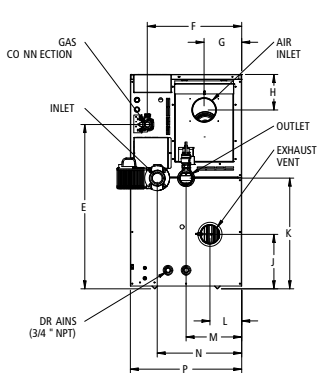

REAR VIEW
(VWH0500N-VWH1000N)

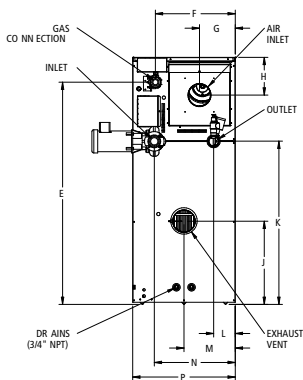

REAR VIEW
(VWH1500N-VWH2000N)

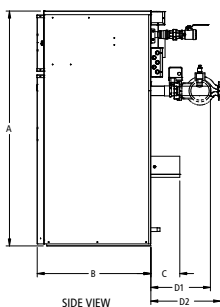

SIDE VIEW

*Pump shipped loose

Model Number	Dimensions in Inches							
	A	B	C	D1	D2	E	F	G
VWH-500N	44-1/2	30-3/8	6	12-1/2	15-1/8	34-1/8	19-5/8	7-3/4
VWH-750N	52-1/8	30-3/8	6	12-1/2	15-1/8	41-3/4	19-5/8	7-3/4
VWH-1000N	59-1/4	30-3/8	6	12-1/2	15-1/8	48-7/8	19-5/8	7-3/4
VWH-1500N	65-3/8	31-5/8	8	16-1/2	19-3/8	58-3/4	21-1/8	9-1/2
VWH-2000N	76-5/8	31-5/8	8	16-1/2	19-3/8	70	21-1/8	9-1/2

Model Number	Dimensions in Inches						
	H	J	K	L	M	N	P
VWH-500N	7-3/8	11-3/8	23	6-1/2	11-1/2	17-1/2	23-1/8
VWH-750N	7-3/8	11-3/8	30-1/2	6-1/2	11-1/2	17-1/2	23-1/8
VWH-1000N	7-3/8	11-3/8	37-5/8	6-1/2	11-1/2	17-1/2	23-1/8
VWH-1500N	9-1/2	22	43-1/4	5-3/4	13-1/2	21-3/8	27-1/8
VWH-2000N	9-1/2	27-3/8	54-3/8	5-3/4	13-1/2	21-3/8	27-1/8

Authorized start-up service included; required to activate warranty.(Continental U.S. Only).
Change "N" to "P" when ordering propane (LP) gas (Example: VWH-750-P).

COMMERCIAL WATER HEATER

BURKAY® ENERGY SAVER COPPER HEAT EXCHANGER



All Non-Ferrous Waterways

- Rustproof because water comes in contact with nothing but copper, brass or bronze
- Copper transfers heat eight times faster than ferrous metals yet offer remarkable structural strength without excessive weight
- Free from the effects of thermal shock

Efficiency Copper Coil Combustion Chamber

- Continuous coils of tightly wound copper tubing form a unique combustion chamber
- Water circulating thru the coils, around the flame, captures radiant heat which may otherwise be lost

High Efficiency Stainless Steel Burner

- Developed especially for A. O. Smith water heaters using the very latest burner principles

Forced Water Circulation Improves System Efficiency

- Water moving at 2 to 4 feet per second helps to prevent lime buildup and also scrubs extra heat from the copper coil combustion chamber



Model	Input Rating BTU/Hr. Natural & Propane Gas	Temperature Rise-100°F Gallons Per Hour
HW-120M	120,000	120
HW-160M	160,000	154
HW-200M	199,000	195
HW-225M	225,00 Nat. Gas Only	217

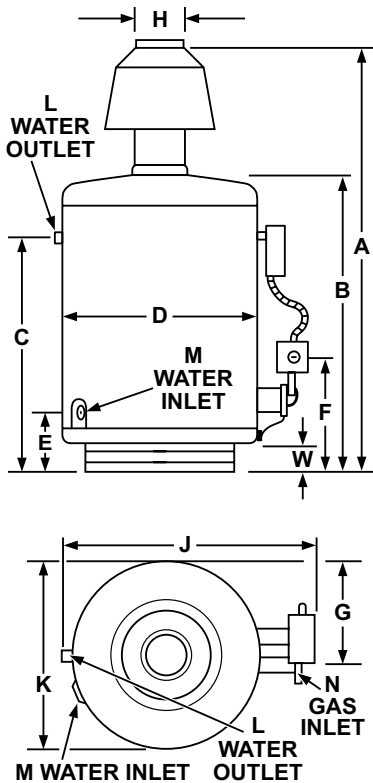

Models	HWH-120	HWH-160	HWH-200	HWH-225
Dimensions in Inches				
A	49-3/8	50-1/8	53-1/4	60
B	30-3/8	30-3/8	33-1/8	33-1/8
C	23-5/8	23-5/8	27-1/8	27-1/8
D	20-3/4	20-3/4	20-3/4	20-3/4
E	5-1/2	5-1/2	5-1/2	5-1/2
F	10	10	10	10
G	11-13/16	11-13/16	11-13/16	11-13/16
H	6	7	7	7
J	26-11/16	26-11/16	26-11/16	26-11/16
K	20-3/4	20-3/4	20-3/4	20-3/4
L	1-1/4 NPT	1-1/4 NPT	1-1/4 NPT	1-1/4 NPT
M	1 NPT	1 NPT	1 NPT	1 NPT
N	1/2 NPT	1/2 NPT	1/2 NPT	1/2 NPT
W	1-3/4	1-3/4	1-3/4	1-3/4
Approx. Shipping Weight	120 lbs.	155 lbs.	165 lbs.	175 lbs.

HOT WATER SUPPLY BOILERS

BURKAY® HWH GAS DOMESTIC WATER HEATERS & BOILERS



All Non-Ferrous Waterways

- All castings are made of bronze or brass
- All water tubes are made from copper
- Brazed joints or flare union construction make the boiler immune to the effects of thermal shock and thermal cycling
- A great boiler for domestic hot water supply

Efficiency Copper Coil Combustion Chamber

- The combustion chamber is a heat exchanger formed from a two passage coil of tightly wound continuous copper tube
- Water circulating through this coil surrounds the main burner and captures the radiant heat
- A wrap of insulation on the outside of the coil retains the heat captured by the circulating water



Model Number	Input Rating BTU/HR Natural & Propane (LP) Gas	Recovery Capacity GPH @ 100°F Rise	Approx. Shipping Weight (lbs)
HW-300	300,000	298	255
HW-399	399,000	392	301
HW-420	420,000	417	301
HW-520	520,000	516	381
HW-670 Nat.	660,000	646	381
HW-670 Prop	670,000	656	381

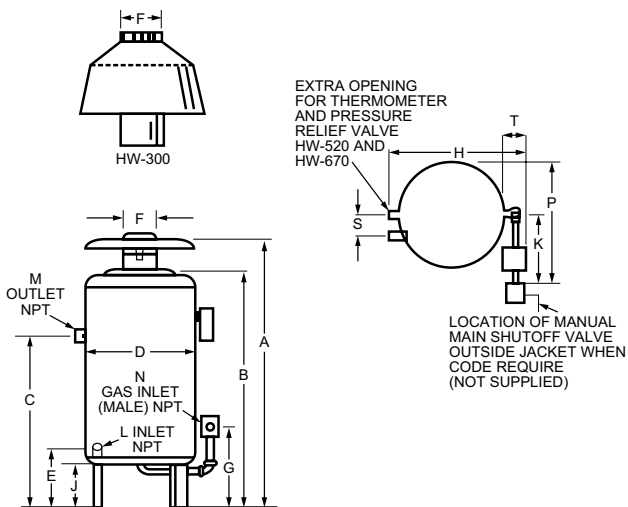

Dimensions in Inches		Models				
		HW-300	HW-399	HW-420	HW-520	HW-670
A	Overall height	65	57-1/8	57-1/8	68-5/16	68-5/16
B	Height to Top of Jacket	43-1/4	45-1/8	45-1/8	56-1/4	56-1/4
C	Floor to Center Line Water Outlet	36	38-3/4	38-3/4	46	46
D	Diameter of Jacket	25-1/4	27	27	27	27
E	Floor to Center Line Water Inlet	12	12	12	12	12
F	Draft Diverter Outlet Diameter	8	10	10	10	12
G	Floor to Center Line Gas Inlet	16-1/2	16-3/4	16-3/4	8	8
H	Overall Depth	29-5/8	31-1/2	31-1/2	36-1/2	36-1/2
J	Support Height	9	9	9	9	9
K	Width of Control String (approx.)	14	14	14	11	11
L	Pipe Size of Water Inlet (NPT)	1-1/4	1-1/2	1-1/2	2	2
M	Pipe Size of Water Outlet (NPT)	1-1/4	1-1/2	1-1/2	2	2
N	Pipe Size of Gas Inlet (NPT)	3/4	3/4	1	1	1
P	Control String Plus 1/2 Jacket Diameter (approx.)	26-5/8	27-1/2	27-1/2	24-1/2	24-1/2
S	Horizontal Length between Water Inlet & Outlet	5-3/8	5-1/2	5-1/2	5-3/4	5-3/4
T	Control String from Jacket	5	5	5	7	7

COMMERCIAL ELECTRIC BOILERS

DURA-POWER™

NW ELECTRIC BOILERS



ASME Code Construction

Incoloy Immersion Heaters

Control and Power Circuit Fusing

Pilot Switch and Light

Heavy-Duty UL-Rated Magnetic
Contactors Rated for 100,000

Low-Water Cutoff

120V Control Circuit

Modulating Step Control

Hydronic Boiler, Not for Potable Water
Applications

1-Year Limited Tank Warranty

- For complete warranty information, consult written warranty or go to hotwater.com.



ASME

UL MINIMUM CLEARANCE REQUIREMENTS:
24" ALL SIDES, 12" TOP

NOTE: ALLOW 30" CLEARANCE FOR HINGED CONTROL COMPARTMENT DOORS.

ELEMENTS CAN BE CHANGED WITH 24" CLEARANCE.

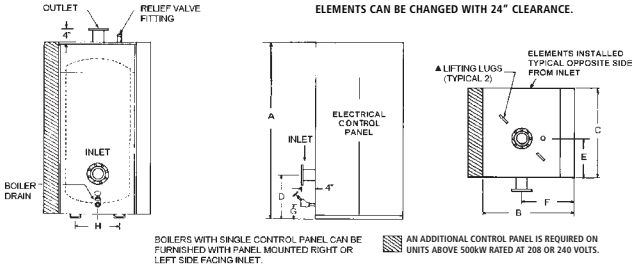

MODELS: NW-37, NW-60, NW-96 AND NW-150

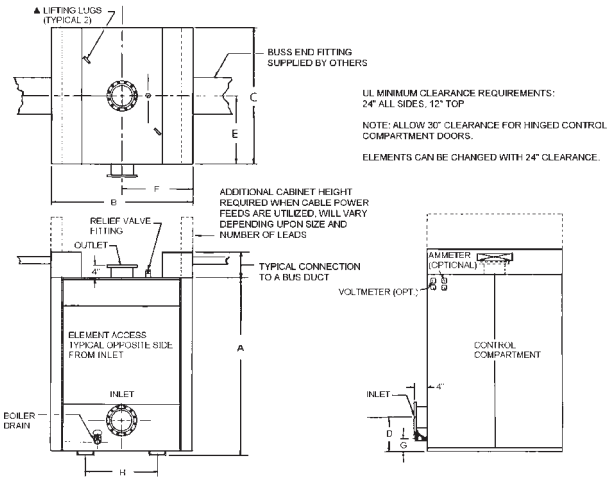

Model Number	Gallon Capacity	Maximum kW Input	Dimensions in Inches							
			A**	B	C	D	E	F	G	H
NW-37	37	180	42	32	30	12-1/2	12	20	4	
NW-60	60	300	57	32	30	12-1/2	12	20	4	
NW-96	96	480	69-1/2	36	38	17	16	24	5	17
NW-150	150	720	69-1/2	54	44	20	19	27	5-1/2	20
NW-220	220	1140	71	60	50	21	25	30	5-1/2	25-1/2
NW-334	334	1740	99	60	50	25	25	30	7-1/4	25-1/2
NW-400	400	2100	90-1/2	66	56	25-1/2	28	33	7-3/4	30
NW-500	500	2580	90-1/2	72	62	26-1/2	31	36	7-3/4	34
NW-570	670	3300	96-1/2	78	68	30-1/2	34	39	7-3/4	38

See heater specification sheet for additional features and options.

**Where overall height is a problem a larger diameter vessel with a reduced height may be furnished.

Fittings under 4" will be threaded type. All fittings 4" and larger will be Flanged.

Lifting lugs and channel skid base on 96 gallon and larger units.

More information on the following page.

COMMERCIAL ELECTRIC BOILERS

DURA-POWER™

NW ELECTRIC BOILERS (CONTINUED)

Model Number	Gallon Capacity	Standard Wattage kW	BTU Output	Gal/Hr. 100°F Rise	Number of Immersion Heaters
NW-37-45-K	37	45	153,585	180	3
NW-37-60-K	37	60	204,720	240	4
NW-37-75-K	37	75	255,975	300	5
NW-37-90-K	37	90	307,170	369	6
NW-37-105-K	37	105	358,365	430	7
NW-37-120-K	37	120	409,560	492	8
NW-37-150-K	37	150	511,950	615	10
NW-37-180-K	37	180	614,340	736	12
NW-60-210-K	60	210	716,730	861	14
NW-60-240-K	60	240	819,120	984	16
NW-60-270-K	60	270	921,510	1,107	18
NW-60-300-K	60	300	1,023,900	1,230	20
NW-96-330-K	96	330	1,126,290	1,353	22
NW-96-360-K	96	360	1,228,680	1,476	24
NW-96-390-K	96	390	1,331,070	1,599	26
NW-96-420-K	96	420	1,433,460	1,722	28
NW-96-450-K	96	450	1,535,850	1,845	30
NW-96-480-K	96	480	1,638,240	1,968	32
NW-150-540-K	150	540	1,843,020	2,214	36
NW-150-600-K	150	600	2,047,800	2,460	40
NW-150-660-K	150	660	2,252,580	2,706	44
NW-150-720-K	150	720	2,457,360	2,952	48
NW-220-780-K	220	780	2,662,140	3,198	52
NW-220-840-K	220	840	2,866,920	3,444	56
NW-220-900-K	220	900	3,071,700	3,690	60
NW-220-960-K	220	960	3,276,480	3,936	64
NW-220-1020-K	220	1,020	3,481,260	4,182	68
NW-220-1080-K	220	1,080	3,636,040	4,428	72
NW-220-1140-K	220	1,140	3,890,820	4,674	76
NW-334-1200-K	334	1,200	4,095,600	4,920	80
NW-334-1260-K	334	1,260	4,300,380	5,166	84
NW-334-1380-K	334	1,380	4,709,940	5,658	92
NW-334-1500-K	334	1,500	5,119,500	6,150	100
NW-334-1620-K	334	1,620	5,529,060	6,642	108
NW-334-1740-K	334	1,740	5,938,630	7,134	116
NW-400-1800-K	400	1,800	6,143,400	7,380	120
NW-400-1860-K	400	1,860	6,348,180	7,626	124
NW-400-1980-K	400	1,980	6,757,740	8,118	132
NW-400-2100-K	400	2,100	7,167,300	8,610	140
NW-500-2220-K	500	2220	7,576,860	9,102	148
NW-500-2340-K	500	2340	7,986,420	9,594	156
NW-500-2460-K	500	2460	8,395,980	10,080	164
NW-500-2580-K	500	2580	8,805,540	10,578	172
NW-670-2700-K	670	2700	9,315,100	11,070	180
NW-670-2820-K	670	2820	9,624,660	11,562	188
NW-670-2940-K	670	2940	10,034,220	12,054	196
NW-670-3060-K	670	3060	10,443,780	12,546	204
NW-670-3180-K	670	3180	10,853,340	13,038	212
NW-670-3300-K	670	3300	11,262,900	13,530	220

Model Number	Steps (Standard)	Standard Number and kW of Steps	Amperage 3 Phase			
			208V	240V	480V	575V
NW-37-45-K	1	1 @ 45	128	108	55	45
NW-37-60-K	1	1@ 60	171	144	73	60
NW-37-75-K	1	1 @ 75	213	180	90	75
NW-37-90-K	3	3 @ 30	250	217	108	90
NW-37-105-K	4	3 @ 30 +1 @15	292	253	126	105
NW-37-120-K	4	4 @ 30	334	289	144	121
NW-37-150-K	5	5 @ 30	417	361	180	151
NW-37-180-K	5	4 @ 30 + 1@ 60	500	433	216	181
NW-60-210-K	5	3 @ 30 + 2 @ 60	584	505	252	211
NW-60-240-K	5	2 @ 30 + 3 @ 60	668	577	288	241
NW-60-270-K	5	1 @ 30 + 4 @ 60	751	650	324	271
NW-60-300-K	5	5 @ 60	834	722	360	301
NW-96-330-K	10	9 @ 30 + 1 @ 60	917	794	396	331
NW-96-360-K	10	8 @ 30 + 2 @ 60	1001	866	432	362
NW-96-390-K	10	7 @ 30 +3 @60	1084	938	468	392
NW-96-420-K	10	6 @ 30 + 4 @ 60	1168	1010	504	422
NW-96-450-K	10	5 @ 30 + 5 @ 60	1251	1083	540	452
NW-96-480-K	10	4 @ 30 + 6 @ 60	1334	1155	576	487
NW-150-540-K	10	2 @ 30 + 8 @ 60	150	1299	648	542
NW-150-600-K	10	10 @ 60	1668	1443	720	602
NW-150-660-K	10	8 @ 60 + 2 @ 90	NOT RECOMMENDED	NOT RECOMMENDED	792	663
NW-150-720-K	10	6 @ 60 + 4 @90			864	723
NW-220-780-K	10	4 @ 60 + 6 @ 90			936	783
NW-220-840-K	10	9 @ 90 + 1 @ 30			1008	843
NW-220-900-K	10	10 @ 90			1080	904
NW-220-960-K	10	8 @ 90 + 2 @ 120			1152	964
NW-220-1020-K	10	6 @ 90 + 4 @ 120			1224	1024
NW-220-1080-K	10	4 @ 90 + 6 @ 120			1296	1084
NW-220-1140-K	10	2 @ 90 + 8 @ 120			1368	1145
NW-334-1200-K	10	10 @ 120			1440	1205
NW-334-1260-K	10	8 @ 120 + 2 @ 150			1512	1265
NW-334-1380-K	10	4 @ 120 + 6 @ 150			1656	1386
NW-334-1500-K	10	10 @ 150			1800	1506
NW-334-1620-K	15	6 @ 90 + 9 @120			1944	1627
NW-334-1740-K	15	2 @ 90 + 13 @ 150			2068	1747
NW-400-1800-K	15	15 @ 120			2160	1807
NW-400-1860-K	15	13 @ 120 + 2 @ 150			2232	1868
NW-400-1980-K	15	9 @ 120 + 6 @ 150			2376	1988
NW-400-2100-K	15	5 @ 120 + 10 @ 150			2520	2109
NW-500-2220-K	15	1 @ 120 + 14 @ 150			2664	2229
NW-500-2340-K	18	18 @ 120 + 2 @ 90			2808	2350
NW-500-2460-K	18	18 @ 120 + 2 @ 150			2952	2470
NW-500-2580-K	18	14 @ 120 + 6 @ 150			3096	2590
NW-670-2700-K	19	10 @ 120 + 10 @ 150			3240	2711
NW-670-2820-K	18	6 @ 120 + 14 @ 150			3384	2832
NW-670-2940-K	18	2 @ 120 + 18 @ 150			3528	2952
NW-670-3060-K	18	18 @ 150 + 2 @ 180			3672	3073
NW-670-3180-K	18	14 @ 150 + 6 @ 180			3816	3193
NW-670-3300-K	18	10 @ 150 + 10 @ 180	3960	3313		

HOT WATER GENERATOR

STEAM OR BOILER HOT WATER HWG GENERATOR SYSTEMS

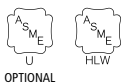

OPTIONAL

All HWG Systems are Fiberglass Insulated and Jacketed

Integral Bronze Circulator Pump

Both Steam and Boiler Water Units are Custom Built to Meet Your Specifications and are Completely Assembled with Components Sized, Piped, and Checked Before Shipping

ASME Rated

Cathodic Protection

Custom Sizes Available up to 12,000 Gallons

Available in Vertical or Horizontal Models

5-Year Limited Tank Warranty and 1-Year Limited Coil Warranty

- For complete warranty information, consult written warranty or go to hotwater.com.

Table HWG-2	Gals./Hr Recovery (Based on Circulating Tank)					
	Steam Press in Coil (psiG)	Coil Sizes (Diameter - Length)				
		4-18	4-36	6-24	6-36	6-54
180°F Boiler Water		45	87	149	223	335
Minimum GPM Required		4	7	13	19	28
212°F Boiler Water		69	135	230	346	518
Minimum GPM Required		6	12	20	29	43

Table HWG-2	Gals./Hr Recovery (Based on Circulating Tank)							
	Steam Press in Coil (psiG)	Coil Sizes (Diameter - Length)						
		8-42	8-60	10-42	10-48	12-36	12-48	14-42
180°F Boiler Water		502	707	949	1079	1135	1544	1823
Minimum GPM Required		42	59	79	90	95	129	152
212°F Boiler Water		778	1094	1469	1670	1757	2390	2822
Minimum GPM Required		65	91	122	140	146	200	235

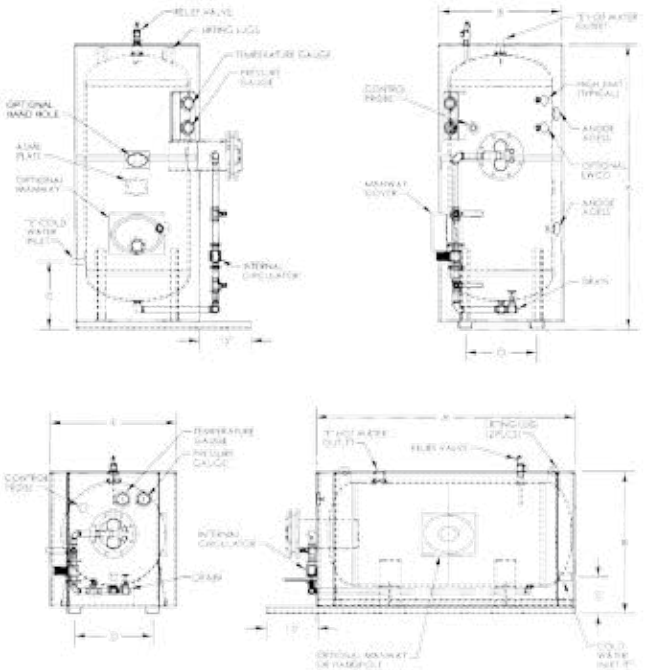

Dimensions in Inches						
Model	Gal	A	B	C	D	E
HWG24-140V	140	89	30	22	11-1/4	2-1/2
HWG30-200V	200	85	36	24	15-1/2	2-1/2
HWG36-350V	350	102	42	25-1/2	19	2-1/2
HWG36-400V	400	107	42	25-1/2	19	2-1/2
HWG48-500V	500	86	54	30	25-1/2	3
HWG48-750V	750	118	54	30	25-1/2	3
HWG48-1000V	1000	150	54	30	25-1/2	3

Dimensions in Inches							
Model	Gal	A	B	C	D	E	F
HWG30-200H	200	77	41	16	26	2-1/2	36
HWG36-350H	350	93	47	16	30	2-1/2	42
HWG36-400H	400	99	47	17	30	2-1/2	42
HWG48-500H	500	79	59	23	42	3	54
HWG48-750H	750	111	59	23	42	3	54
HWG48-1000H	1000	143	59	23	42	3	54

COMMERCIAL STORAGE TANKS

STANDARD JACKETED STORAGE TANKS

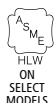

Glasslined Tank

- Alkaline borosilicate composition permanently fused to steel by firing at a temperature of 1600°F, providing years of corrosion protection and dependable use.

Ideal for Use with Gas Fired Copper Heat Exchanger Equipment for Potable Water at Temperatures Up to 180°F

Threaded Openings

- All tanks furnished with threaded openings for thermometer, relief valve, 2" recirculation lines, tank stat, and drain valve.

ASME Construction on Select Models.

- 160 psi standard working pressure on all models.

Anodic Protection

TJ-80S, TJ-80A, TJV-120M and TJV-120A

- Fits through 30" door
- Magnesium anode for anti-corrosion protection

Meets R12.5 Minimum Thermal Insulation Requirements of the U.S. Department of Energy and Current Edition of ASHRAE/IES 90.1

5-Year Heat Exchanger and 1-Year Parts Limited Warranty

- For complete warranty information, consult written warranty or go to hotwater.com.

Model Number	Gallon Capacity	Overall Length (Inches)	Diameter (Inches)	Approx. Shipping Weight (lbs)
TJ80S Jacketed-Vertical Only**	80	63	25-1/4	236
TJV120M Jacketed-Vertical Only**	119	62	29-3/8	320
TJ80A Jacketed-Vertical Only***	80	54-7/8	26-1/2	369
TJV-120A***	119	61-3/4	28	411
TJV-200M (ASME)**	175	77	32	560

Plant of Manufacture:

*Renton, Washington only

**McBee, South Carolina only

***Both McBee, South Carolina and Renton, Washington

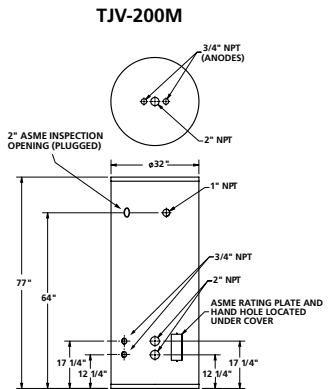
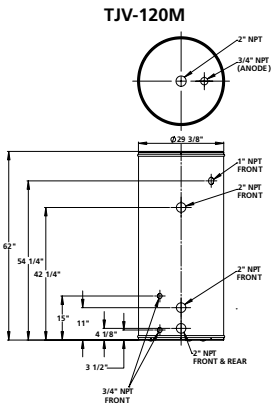
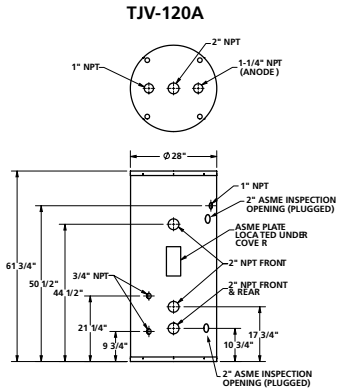
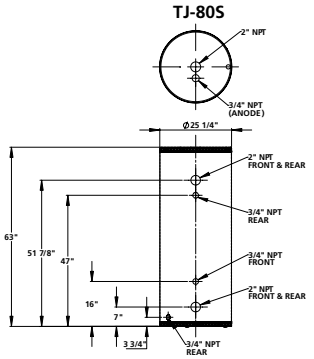
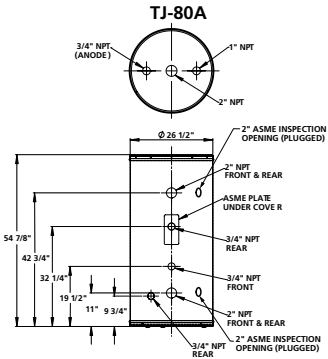

COMMERCIAL STORAGE TANKS

CUSTOM-LINE FACTORY JACKETED & INSULATED STORAGE TANKS



All tanks derived from HD (high Draw) tanks listed on pages 172-175.

Standard Sizes

- From 140 to 1,000 gallons. all stock tanks glasslined.

Horizontal or Vertical Mounting Options Available

High-Density, Fiberglass Insulated Jackets

Meet R12.5 Minimum Thermal Insulation Requirements of the U.S. Department of Energy and Current Edition of ASHRAE/IES 90.1

ASME Construction

- Available in 100, 125, 150 and 160 working pressures; 125 standard.

Anodic Protection

Accessories

- Tanks will be supplied with the fittings located as indicated on the drawings unless specified otherwise. An 11" x 15" manhole or 4" x 6" handhole is optional on glasslined tanks 36" diameter or less.

Cabinet

- Heavy gauge steel with high quality powder coat paint provides additional insulating qualities for greater energy savings.

5-Year Limited Tank Warranty

- For complete warranty information, consult written warranty or go to hotwater.com.

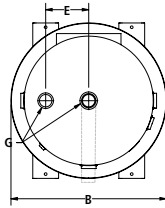
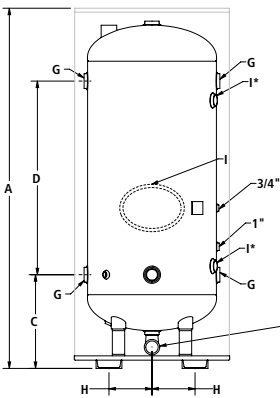

*Note: These connections are not for piping connections. They are the anode locations and also serve as the required ASME 2" inspection openings.

STORAGE TANK SELECTION

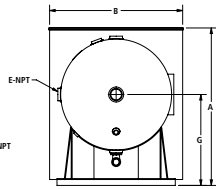
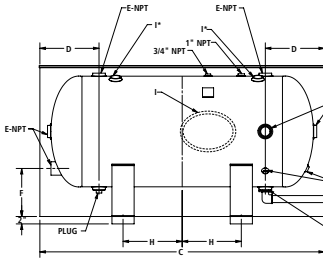

*Note: These connections are not for piping connections. They are the anode locations and also serve as the required ASME 2" inspection openings.

Model Number & Gallon Capacity	Dimensions in Inches									
	A	B	C	D	E	F	G	H	"1" ASME Inspection Openings	J
TJH-200	41	36	77	16	2-1/2	11	23	16	2	1-1/2
TJH-250	41	36	90	15	2-1/2	11	23	22-1/2	2	1-1/2
TJH-350	47	42	93	17-1/2	2-1/2	10	26	22-1/2	2	1-1/2
TJH-400	47	42	99	17-1/2	2-1/2	10	26	26	2	1-1/2
TJHT-500	53	48	94	21	3	11	29	19-1/2	12 X 16	1-1/2
TJH-500	59	54	79	22-3/4	3	12	32	11	12 X 16	1-1/2
TJH-750	59	54	111	22-3/4	3	12	32	27	12 X 16	1-1/2
TJH-1000	59	54	143	22-3/4	3	11	32	43	12 X 16	1-1/2

Model Number & Gallon Capacity	Dimensions in Inches								
	A	B	C	D	E	F	G	H	"1" ASME Inspection Openings
TJV-140	87	30	21-1/2	51	8	1-1/2	2-1/2	6-3/8	2
TJV-200	83	36	22	45	10	1-1/2	2-1/2	7-3/4	2
TJV-250	96	36	22	58	10	1-1/2	2-1/2	7-3/4	2
TJV-350	97	42	24-1/2	54	14	1-1/2	2-1/2	9-1/2	2
TJV-400	105	42	24-1/2	61	14	1-1/2	2-1/2	9-1/2	2
TJVT-500	100	48	27	52	16	1-1/2	3	11-5/16	12 X 16
TJV-500	84	54	27-3/4	33-1/4	18	1-1/2	3	12-3/4	12 X 16
TJV-750	116	54	27-3/4	65-1/2	18	1-1/2	3	12-3/4	12 X 16
TJV-1000	150	54	27-3/4	97-1/2	18	1-1/2	3	12-3/4	12 X 16

For Cement or Epoxy linings Order "HD" tanks with jackets and insulation.

COMMERCIAL STORAGE TANKS

UNINSULATED STANDARD STOCK

BARE STORAGE TANKS



Glasslined per ASME, HLW Procedures

Horizontal or Vertical Mounting Options Available

High-Density, Fiberglass Insulated Jackets or Bare Steel Tanks

Cement or Epoxy Linings Available

ASME Construction

Magnesium Anodes Protect Against Corrosion.

Meets R12.5 Minimum Thermal Insulation Requirements of the U.S. Department of Energy and Current Edition of ASHRAE/IES 90.1



5-Year Limited Tank Warranty

- For complete warranty information, consult written warranty or go to hotwater.com.

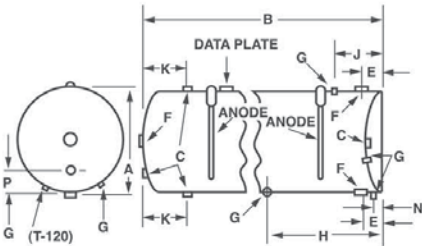

FIGURE 1 - T-80, T-120
NOTE: T-120 SHOWN.

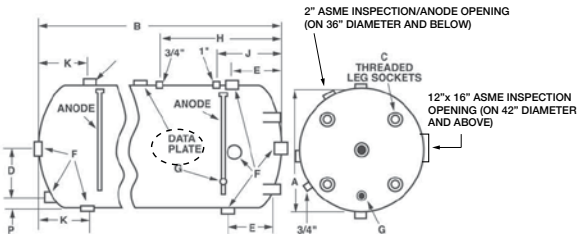

FIGURE 2 - T-140 THRU T-1000A
TL-500 - HORIZONTAL MOUNTING ONLY.
NO LEG SOCKETS.

Model Number	Gallon Capacity	Overall Dimensions in Inches	Approx. Shipping Weight (lbs)
T-80 STD	80	20 X 62-1/8	170
T-120 STD	119	24-1/4 X 65	287
T-200 STD	200	30 X 72	460
T-350 STD	350	36 X 88	670
T-140 ASME	140	24 X 76-1/4	400
T-200 ASME	200	30 X 72	460
T-250 ASME	250	30 X 84	505
T-325 ASME	325	34 X 84	600
T-350 ASME	350	36 X 88	670
T-400 ASME	400	36 X 97	775
TN-500 ASME	500	42 X 89	815
T-500 ASME	500	48 X 74	950
T-750 ASME	750	48 X 106	1290
T-1000 ASME	1000	48 X 138	1655

Model Number	Dimensions in Inches					
	A	B	C	D	E	F
T-80 STD	20	61-1/2	2	n/a	7	2
T-120 STD	24-1/4	64-3/8	2-1/2	n/a	7	2-1/2
T-200 STD	30	70-3/4	2-1/2	10	13	2-1/2
T-350 STD	36	86	2-1/2	14	16	2-1/2
T-140 ASME	24	75	2-1/2	8	12	2-1/2
T-200 ASME	30	70-3/4	2-1/2	10	13	2-1/2
T-250 ASME	30	84	2-1/2	10	13-1/4	2-1/2
T-325 ASME	34	84	2-1/2	14	16	2-1/2
T-350 ASME	36	86	2-1/2	14	16	2-1/2
T-400 ASME	36	96	2-1/2	14	16	2-1/2
TN-500 ASME	42	88	3	16	18	3
T-500 ASME	48	72-3/4	3	18	18	3
T-750 ASME	48	105	3	18	19-3/4	3
T-1000 ASME	48	136	3	18	19-3/4	3

Model Number	Dimensions in Inches					
	G	H	J	K	N	P
T-80 STD	3/4	46-1/4	16	3-1/2	3-1/4	4
T-120 STD	3/4	34-1/2	15-1/2	10-1/2	3-1/2	4-1/8
T-200 STD	3/4	28-1/2	19-1/2	13	N/A	4
T-350 STD	3/4	31-1/2	20-1/4	16	N/A	4
T-140 ASME	3/4	27-1/2	18-1/2	12	N/A	4
T-200 ASME	3/4	28-1/2	19-1/2	13	N/A	4
T-250 ASME	3/4	28-1/2	19-1/2	13	N/A	4
T-325 ASME	3/4	28-3/4	19-3/4	13-3/4	N/A	5
T-350 ASME	3/4	31-1/2	20-1/4	16	N/A	4
T-400 ASME	3/4	31-1/2	20-1/4	16	N/A	4
TN-500 ASME	3/4	33-1/2	24-1/2	18	N/A	5
T-500 ASME	3/4	32-3/4	26-3/4	19-3/4	N/A	6
T-750 ASME	3/4	32-3/4	26-3/4	19-3/4	N/A	6
T-1000 ASME	3/4	32-3/4	26-3/4	19-3/4	N/A	6

COMMERCIAL STORAGE TANKS

HEAVY-DUTY LARGE VOLUME STORAGE TANKS MODEL HD CUSTOM-BUILT



Custom-Built Tanks From 80 to 12,500 Gallons.

Horizontal or Vertical Mounting Options Available

High-Density, Fiberglass Insulated Jackets or Bare Steel Tanks

Glasslined, Cement or Epoxy Linings Available

ASME Construction

- Available in 125, 150 and 160 psi working pressure.

Anodic Protection

Manholes, Handholes, Additional Tank Opening, M Lifting Lugs, Angle Legs, Ring Bases and Horizontal Tanks Saddles All Available as Options.

Meets R12.5 Minimum Thermal Insulation Requirements of the U.S. Department of Energy and Current Edition of ASHRAE/IES 90.1

5-Year Limited Tank Warranty

- For complete warranty information, consult written warranty or go to hotwater.com



Model Number	Gallon Capacity	Dimensions Diameter x O.A. Length (Inches)	Shipping Weight (lbs.)		
			Black Steel	Glasslined Epoxy	Cement
HD20-80	80	20 x 60	210	210	–
HD20-100	100	20 x 72	294	294	–
HD24-125	125	24 x 66	420	366	–
HD24-140	140	24 x 75	438	422	–
HD24-175	175	24 x 90	489	494	–
HD30-175	175	30 x 60	575	469	870
HD30-200	200	30 x 71	657	505	990
HD30-250	250	30 x 84	740	567	1,109
HD30-300	300	30 x 99	803	654	1,238
HD36-250	250	36 x 60	873	521	984
HD36-300	300	36 x 71	998	613	1,121
HD36-350	350	36 x 86	1,122	682	1,260
HD36-400	400	36 x 93	1,198	727	1,340
HD36-500	500	36 x 122	1,445	869	1,616
HD42-375	375	42 x 67	1,105	855	1,299
HD42-450	450	42 x 79	1,260	946	1,480
HD42-500	500	42 x 88	1,415	991	1,679
HD42-600	600	42 x 103	1,574	1,097	1,885
HD42-700	700	42 x 119	1,965	1,188	2,202
HD42-800	800	42 x 134	2,008	1,399	2,451
HD48-500	500	48 x 73	1,680	1,072	1,750
HD48-600	600	48 x 81	1,878	1,231	1,984
HD48-700	700	48 x 93	2,077	1,365	2,216
HD48-750	750	48 x 105	2,300	1,455	2,468
HD48-900	900	48 x 117	2,499	1,633	2,715
HD48-1000	1,000	48 x 137	2,697	1,811	3,023
HD48-1250	1,250	48 x 159	3,292	2,157	3,639
HD48-1500	1,500	48 x 190	3,912	2,425	4,337
HD54-650	650	54 x 71	2,200	1,239	2,061
HD54-750	750	54 x 81	2,461	1,403	2,327
HD54-900	900	54 x 95	2,752	1,566	2,613
HD54-1000	1,000	54 x 105	3,010	1,730	2,936
HD54-1250	1,250	54 x 129	3,531	2,055	3,408
HD54-1500	1,500	54 x 153	4,080	2,381	3,959
HD54-1800	1,800	54 x 181	4,861	2,870	4,756
HD60-800	800	60 x 72	2,324	1,769	2,509
HD60-1000	1,000	60 x 88	2,758	2,061	3,011
HD60-1250	1,250	60 x 107	3,367	2,491	3,706
HD60-1500	1,500	60 x 126	3,657	2,679	4,101
HD60-1750	1,750	60 x 146	4,166	3,126	4,712

Line drawing and dimensions on the following page.

COMMERCIAL STORAGE TANKS

HEAVY-DUTY LARGE VOLUME STORAGE TANKS MODEL HD

CUSTOM-BUILT *(CONTINUED)*

Model Number	Gallon Capacity	Dimensions Diameter x OAL (Inches)	Shipping Weight (lbs)		
			Black Steel	Glasslined Epoxy	Cement
HD60-2000	2,000	60 x 165	4,844	3,505	5,432
HD66-1000	1,000	66 x 75	2,760	1,929	2,808
HD66-1500	1,500	66 x 107	3,886	2,675	4,011
HD66-2000	2,000	66 x 139	5,010	3,422	5,184
HD66-2500	2,500	66 x 171	6,101	4,170	6,388
HD72-2500	2500	72 x 147	6,224	4,126	5,800
HD72-3000	3,000	72 x 174	7,116	4,669	6,653
HD72-3500	3,500	72 x 201	8,493	5,212	7,943
HD72-4000	4,000	72 x 228	9,831	6,027	9,238
HD84-4000	4,000	84 x 173	9,508	6,348	9,093
HD84-5000	5,000	84 x 212	11,865	7,871	11,354
HD84-6000	6,000	84 x 252	13,599	9,012	13,063
HD84-8000	8,000	84 x 330	17,737	11,674	17,070
HD96-7500	7,500	96 x 244	15,843	11,711	16,090
HD96-10000	10,000	96 x 319	20,628	15,261	20,950
HD96-12500	12,500	96 x 395	24,590	18,303	24,892

CUSTOM-LINE STORAGE TANKS (20" THRU 96" DIA. TANKS)

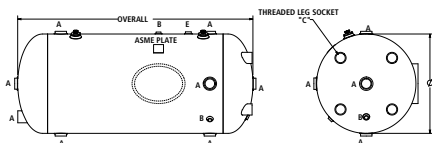

NOTE:

- 1) 54" DIAMETER AND LARGER TANKS MUST BE ORDERED WITH ANGLE LEGS RATHER THAN THREADED LEG SOCKETS FOR VERTICAL INSTALLATIONS.
 - 2) SPECIFY FOR HORIZONTAL OR VERTICAL INSTALLATION.
 - 3) NO LEG SOCKETS PROVIDED ON HORIZONTAL TANKS.
- 2 each 2" ASME inspection openings are standard on tanks 36" diameter and below.
 12"x16" ASME inspection openings are standard on tanks with 42" diameters and above.

CUSTOM-LINE STORAGE TANKS (20" THRU 96" DIA. TANKS)

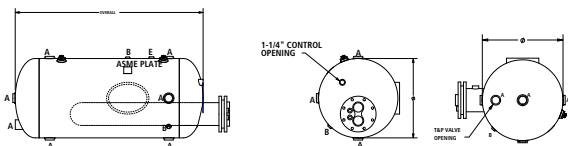

NOTE:

- 1) ADD SUFFIX "ES" FOR SINGLE - WALL OR "ED" FOR DOUBLE - WALL TO MODEL NUMBER WHEN EQUIPPED WITH A TUBE TANK HEATER (i.e.: HD-36-350ES).
- 2) SPECIFY FOR HORIZONTAL OR VERTICAL INSTALLATION.
- 3) NO LEG SOCKETS PROVIDED ON HORIZONTAL TANKS.

ALL DIMENSIONS IN INCHES

DIMENSION CHART					
DIMENSION	A	B	C	D	E
20	2	3/4	1 1/2	6	3/4
24 THRU 36	2 1/2	3/4	2 1/2	8	1
42 AND 48	3	3/4	3	10	1
54 THRU 96	3	3/4	3	10	1

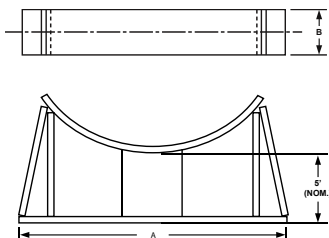
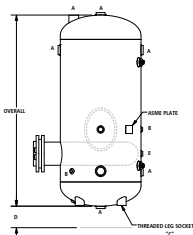

Tank Saddles			
A.O.Smith Part Number	Tank Diameter	A	B
P2-2600-20	20	22	6
P2-2600-24	24	26	6
P2-2600-30	30	32	6
P2-2600-36	36	38	6
P2-2600-42	42	44	6
P2-2600-48	48	50	6
P2-2600-54	54	56	8
P2-2600-60	60	62	8
P2-2600-66	66	58	8
P2-2600-72	72	74	10
P2-2600-84	84	86	10
P2-2600-96	96	98	10

COMMERCIAL WATER HEATER

AC-U-TEMP COMPLETE HOT WATER SYSTEMS



Standard Tank Sizes from 80 to 1000 Gallons

Ac-U-Temp System Eliminates Costly Field Errors

Simplifies Installation

Standard Ac-U-Tanks are Factory Jacketed and Insulated

All Systems are Built to Order

Multi-Heater Systems for 50%-100% Back-Up

Superior I-Beam Skid

Factory Hydrostatic and Fire-Tested Before Shipping

ASME Relief Valve 125#

Tank Temperature Sensor

Tank Thermometer

Isolation Valves

Custom Tank Sizes to 10,000 Gallons

5-Year Limited Heat Exchanger Warranty and 5-Year Limited Tank Warranty

- For complete warranty information, consult written warranty or go to hotwater.com.



INSTANTANEOUS SEMI-INSTANTANEOUS HWI WATER HEATERS

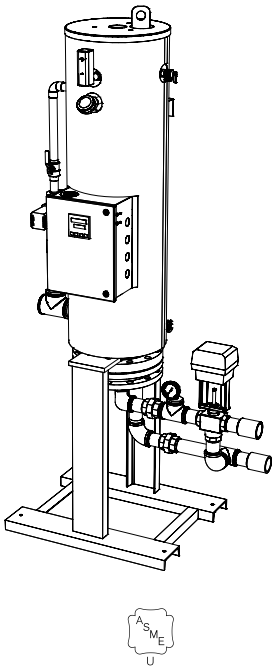

A. O. Smith's HWI Models are Available for Operation with Steam or Boiler Water as the Energy Source.; They are Factory Assembled with Components Sized, Piped and Checked at the Factory Before Shipment; HWI Models are All Space Saving Vertical Models.

Code Listing: The System Will Employ an ASME "U" Code Shell; Fitted with an ASME "U" Code 3/4" Diameter Copper Tube Heat Exchanger.

Integral Pump: The HWI System Will Employ an Integral Bronze Circulator Pump.

Steam Units - Steam Trim Consists of Temperature Control Valve, Inlet and Auxiliary Steam Traps, Inlet and Auxiliary Strainers, Steam Pressure Gauge with Siphon, Vacuum Breaker and Air Vent.

Boiler Units: Boiler Water Trim Includes Temperature Control Valve and Boiler Water Temperature Gauge.

Control Features

- Single Point Wiring – single 120V connection, controls including integral circulation
- On/Off switch-allows local On/Off for service
- Temperature Readout – LED readout of water temperature
- PID Temperature Control – modulates electrical control valve
- High Temperature Limit – Closes main valve under over temperature condition
- Remote Temperature Signal
- 2-Wire RS485 – Communication (MODBUS or ASCII)

CONSULT THE XPERT.



Confidently select the right water heater for your floor plans with the help of an Xpert. With just a few quick questions, the Xpert Product Selection Tool evaluates A. O. Smith's full range of product options against your installation, energy efficiency and usage requirements. The result is a custom selection of water heaters recommended just for you.

Visit hotwater.com/Xpert
to consult the Xpert
or download the A. O. Smith App.

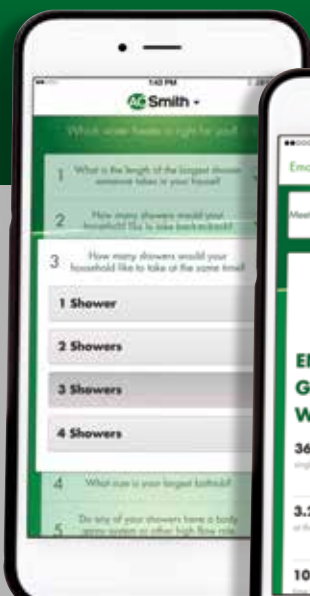



A. O. Smith | 500 Tennessee Waltz Parkway | Ashland City, TN 37015
800.527.1953 | hotwater.com

AOSAA80000 | June | © 2017 A. O. Smith Corporation | Printed in U.S.A.