



The Product Preservers™ Powered Anode System replaces sacrificial anodes which are normally shipped with water heaters.

The Powered Anode System has exclusive technology that can sense water conditions and provide the proper level of corrosion protection. In some areas, sulfates in the water react with the anode in the water heater to create hydrogen sulfide which gives hot water a rotten egg or sulfur like smell. The Powered Anode System eliminates the reaction and solves most smelly water issues.

SPECIFICATIONS

The Powered Anode System can be used with any water heater which is 50 gallons or less and contains a dedicated sacrificial anode. An application where the water heater is installed in the attic area is acceptable; however, the Powered Anode System is not recommended for outdoor water heater applications.

FEATURES

- Patented adaptive technology to quickly adjust to the local water conditions.
- Built-in LED fault light and audible alarm for system notifications.
- Easy installation with a standard 120 volt wall outlet.
- Eliminates smelly water caused by sulfate reactions with sacrificial magnesium anodes.
- Protects for years; no maintenance required.
- Great for softened water applications.

KIT COMPONENTS

- Control Module with two self-tapping screws
- Anode (electrode)
- Power Supply (Input 120 VAC/Output to module: 12 VDC)
- Wiring Harness
- Kit #100305721

ENVIRONMENTAL SPECIFICATIONS

- Humidity up to 95% non-condensing.
- Temperature, operational = 4°F to 158°F (-20°C to 70°C)
- Temperature, storage = -40°F to 176°F (-40°C to 80°C)
- Vibration = 0.5G

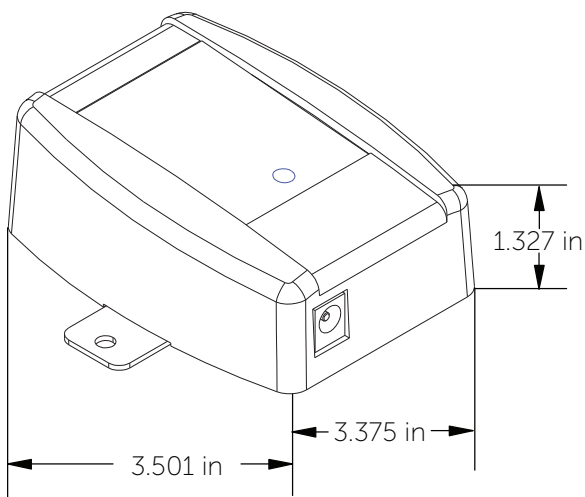

Front View of Control Module

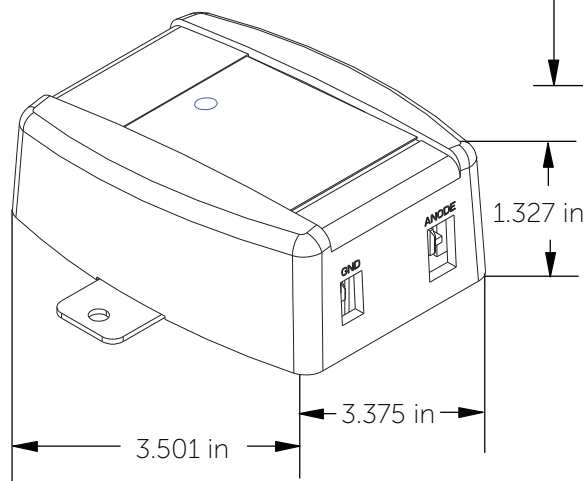

Back View of Control Module

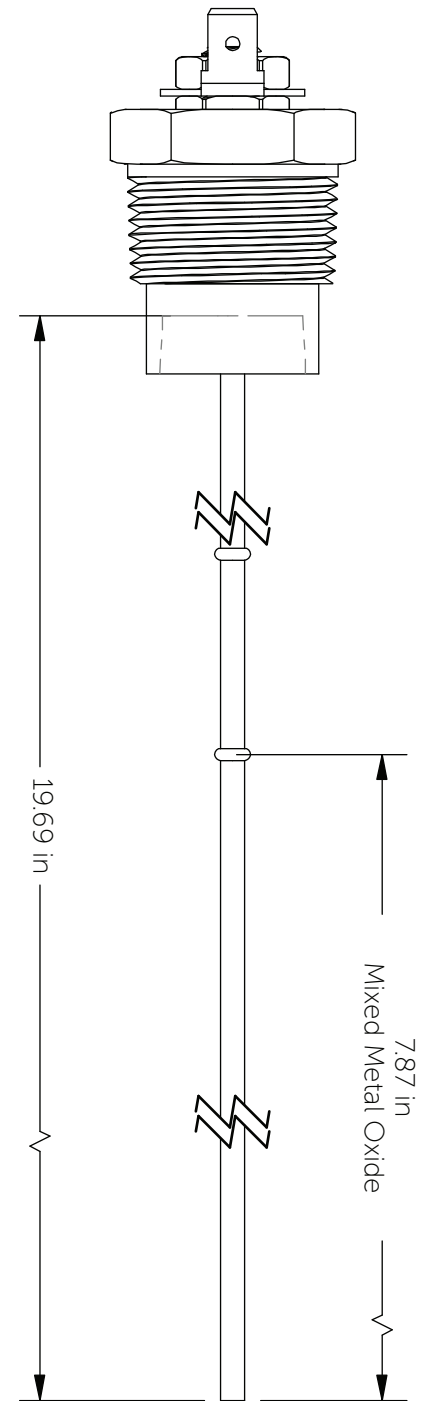

Distributed by
APCOM
125 Southeast Pkwy
Franklin, TN 37064
www.productpreservers.com

Printed in U.S.A.