

ASTRO 2 | THREE SPEED CIRCULATORS | SUBMITTAL

File No: 10.584
 Date: JULY 05, 2013
 Supersedes: 10.584
 Date: MAY 08, 2013

Job: _____ Representative: _____
 _____ Ordered by: _____ Date: _____
 Engineer: _____ Submitted by: _____ Date: _____
 Contractor: _____ Approved by: _____ Date: _____

TECHNICAL DATA

Certification: ETL listed for US and Canada (conforms to UL STD.778 certified to CSA STD. C22.2 NO.108-01 NSF 372 (for lead free bronze and stainless steel models)

Flow range: 0 - 64 USgpm / 0 - 4.04 L/s

Head range: 0 - 42.0 FEET / 0 - 12.8 METERS

Maximum fluid temperature: 185°F / 85°C (ASTRO 286 UP TO 1.35A)
 150°F / 65°C (ASTRO 286 OVER 1.35A)
 230°F / 110°C† (ALL OTHERS)

Maximum working pressure: 150 psi / 1034 kPa

MATERIALS OF CONSTRUCTION

Pump body: Cast iron (closed systems)
 Lead free bronze* (open systems)
 Stainless steel* (open systems)

Impeller: PA66

Shaft: Ceramic

Bearings: Ceramic

Gasket material: EPDM

DIMENSIONS AND WEIGHTS

LEAD FREE BRONZE*	A	B	C	D	E	F	CONNECTION TYPE & SIZE	WEIGHT
Astro 225BS ½" SWT	5.00 (127)	5.00 (127)	4.13 (105)	—	3.00 (76)	—	Sweat - ½"	6.0 (2.7)
Astro 225BS ¾" SWT	5.00 (127)	5.00 (127)	4.13 (105)	—	3.00 (76)	—	Sweat - ¾"	6.0 (2.7)
STAINLESS STEEL*	A	B	C	D	E	F	CONNECTION TYPE & SIZE	WEIGHT
Astro 220ssu**	6.00 (152)	5.00 (127)	4.00 (102)	—	3.00 (76)	—	Union - 1¼" NPSM	6.5 (2.9)
Astro 225ssu**								
Astro 230ss**	6.38 (162)	6.00 (150)	4.00 (102)	4.00 (102)	3.00 (76)	3.25 (80)	Flange - (2) ½" dia. bolt holes	8.0 (3.6)
Astro 250ss**								
Astro 210ss**								
Astro 280ss (230V)**	6.50 (165)	6.37 (162)	4.87 (124)	4.00 (102)	3.50 (90)	3.13 (80)	Flange - (2) ½" dia. bolt holes	10.1 (4.6)
Astro 286ss**								
Astro 290ss**	8.50 (216)	6.65 (169)	5.20 (132)	4.00 (102)	3.50 (90)	3.45 (88)	Flange - (2) ½" dia. bolt holes	13.2 (6.0)
CAST IRON	A	B	C	D	E	F	CONNECTION TYPE & SIZE	WEIGHT
Astro 230ci**	6.38 (162)	6.00 (150)	4.00 (102)	4.00 (102)	3.00 (76)	3.25 (80)	Flange - (2) ½" dia. bolt holes	8.0 (3.6)
Astro 230ci-R**								
Astro 250ci**	6.38 (162)	6.00 (150)	4.00 (102)	4.00 (102)	3.00 (76)	3.25 (80)	Flange - (2) ½" dia. bolt holes	8.0 (3.6)
Astro 250ci-R**								
Astro 210ci**								
Astro 280ci (230V)**	6.50 (165)	6.37 (162)	4.87 (124)	4.00 (102)	3.50 (90)	3.13 (80)	Flange - (2) ½" dia. bolt holes	10.1 (4.6)
Astro 286ci**								
Astro 290ci**	8.50 (216)	6.65 (169)	5.20 (132)	4.00 (102)	3.50 (90)	3.45 (88)	Flange - (2) ½" dia. bolt holes	13.2 (6.0)

NOTE: All dimensions are in inches (mm) and weights in lbs (kg).

* Certified <0.25 weighted average percent lead and complies with California Health and Safety Code Section 116875 (commonly known as AB 1953).

** Removable check valve installed at pump outlet.

† For open systems, it is recommended that the fluid temperature be less than 150°F (66°C) to avoid precipitation of calcium.

MOTOR DATA

MODEL	ELECTRICAL INPUT	SPEED	FULL LOAD AMP DRAW (A)	NOMINAL POWER (W)
ASTRO 210CI/SS		3	1.06	200
		2	1.50	
		1	1.72	
ASTRO 220SSU		3	0.29	33
		2	0.27	
		1	0.20	
ASTRO 225BS		3	0.64	75
		2	0.49	
		1	0.38	
ASTRO 225SSU		3	0.69	83
		2	0.55	
		1	0.43	
ASTRO 230SS/CI/CI-R	115V, 60HZ Single phase	3	0.81	97
		2	0.58	
		1	0.45	
ASTRO 250SS/CI/CI-R		3	0.98	117
		2	0.79	
		1	0.65	
ASTRO 280CI/SS		3	1.90	218
		2	1.80	
		1	1.50	
ASTRO 290CI/SS		3	1.90	218
		2	1.60	
		1	1.40	
ASTRO 280CI/SS 230V	230V, 60HZ Single phase	3	0.90	210
2		0.86		
1		0.80		
ASTRO 286CI/SS		1	1.60	370

ASTRO 225BS

ASTRO 220SSU & 225SSU

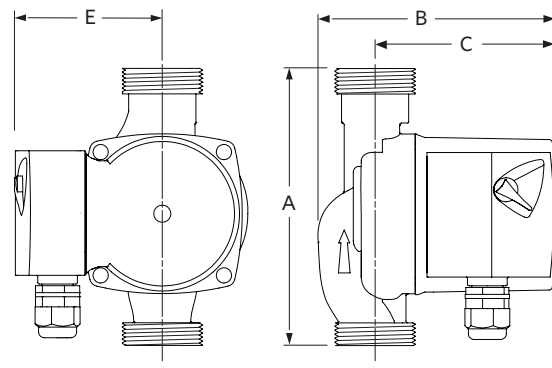
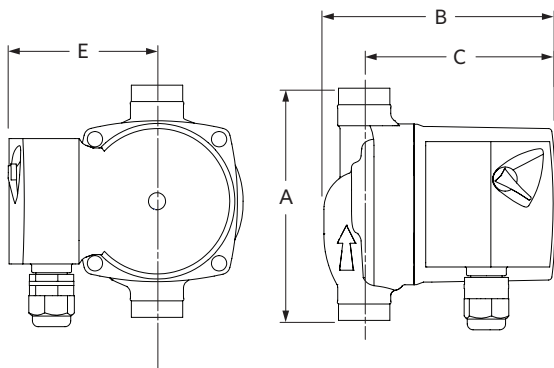

ASTRO 230SS/CI & 250SS/CI

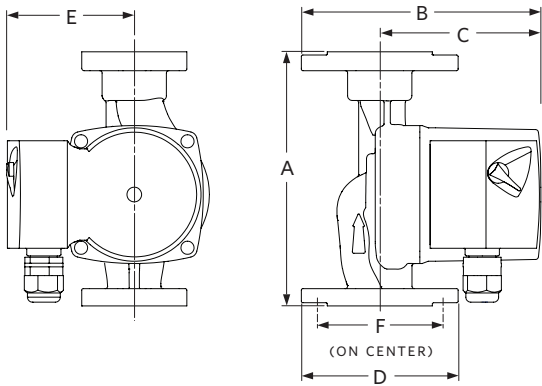

ASTRO 230CI-R & 250CI-R

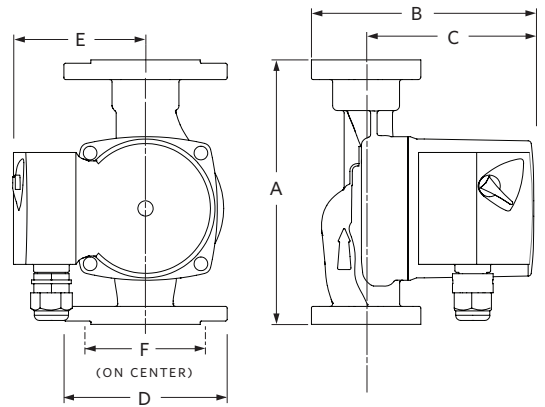

ASTRO 280CI, 290CI/SS & 286CI/SS

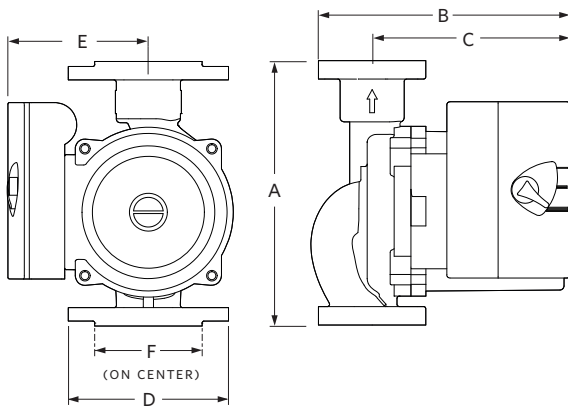

ASTRO 210CI/SS & 280SS

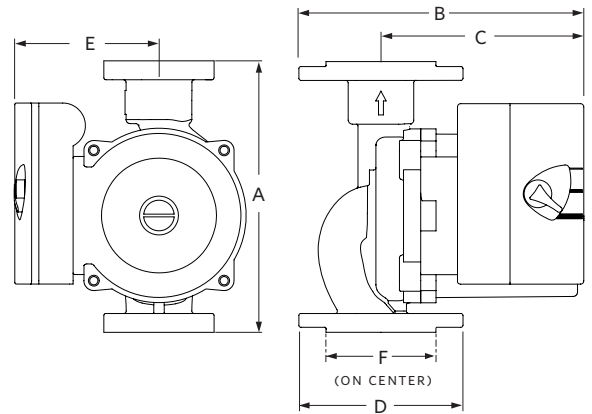

HARDWARE KIT

Companion flange kit (contains two (2) flanges, hardware and gaskets)

Cast iron: 0.75", 1", 1.25", 1.5"

Bronze: 0.75", 1", 1.25", 1.5"

Union fitting (contains two (2) half unions and gaskets)

1.25" NPSM to:

Brass/Lead free bronze: 0.5" sweat, 0.75" sweat, 0.75" FNPT

CHECK VALVE SIZE

CHECK VALVE SIZE	MODEL
1" Diameter	ASTRO 220SSU, ASTRO 225SSU
1¼" Diameter	ASTRO 210, ASTRO 230, ASTRO 250, ASTRO 280, ASTRO 286
1½" Diameter	ASTRO 290

PERFORMANCE CURVES

ASTRO 225BS, 225SSU

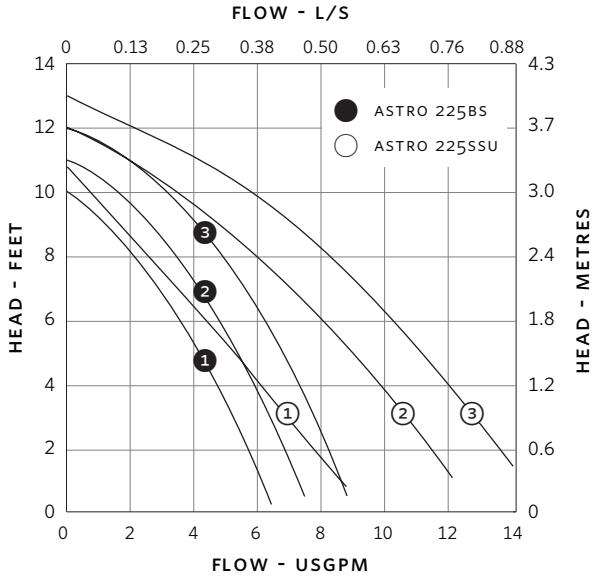

ASTRO 220, 230, 250

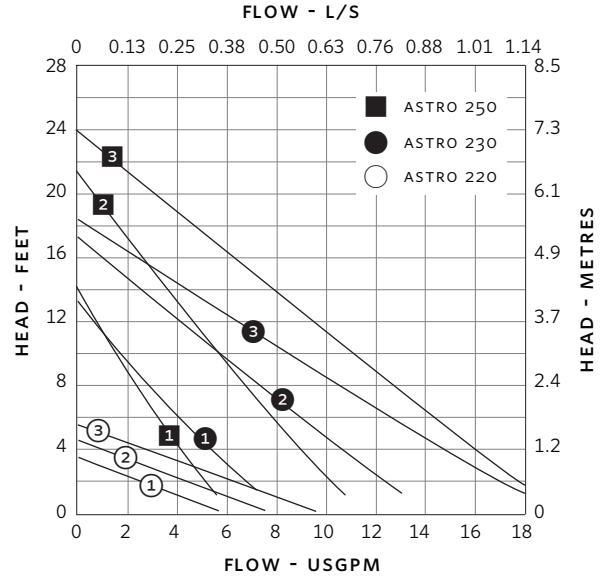

ASTRO 210, 290

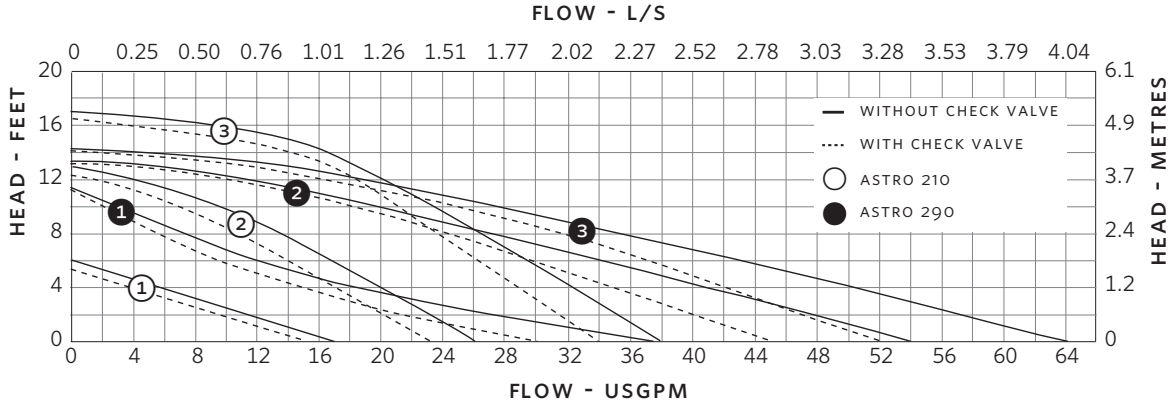

ASTRO 280, 286

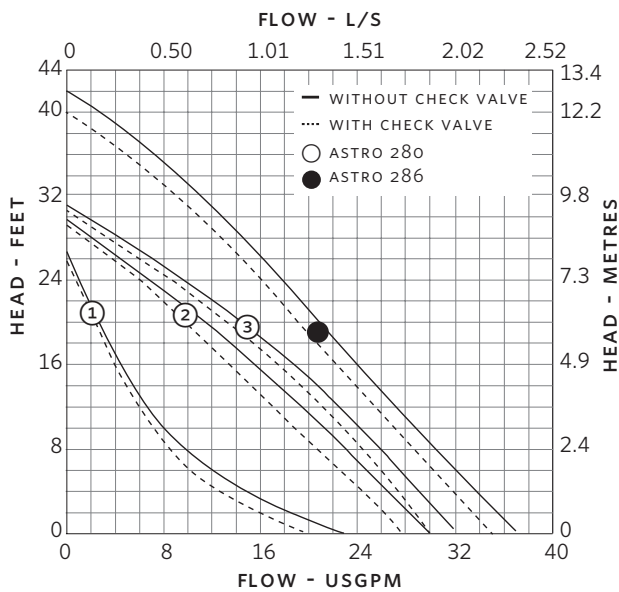

TORONTO
+1 416 755 2291

BUFFALO
+1 716 693 8813

BIRMINGHAM
+44 (0) 8444 145 145

MANCHESTER
+44 (0) 8444 145 145

BANGALORE
+91 (0) 80 4906 3555

SHANGHAI
+86 21 3756 6696