

Oval Vent Pipe Knockouts

4" Box Detail

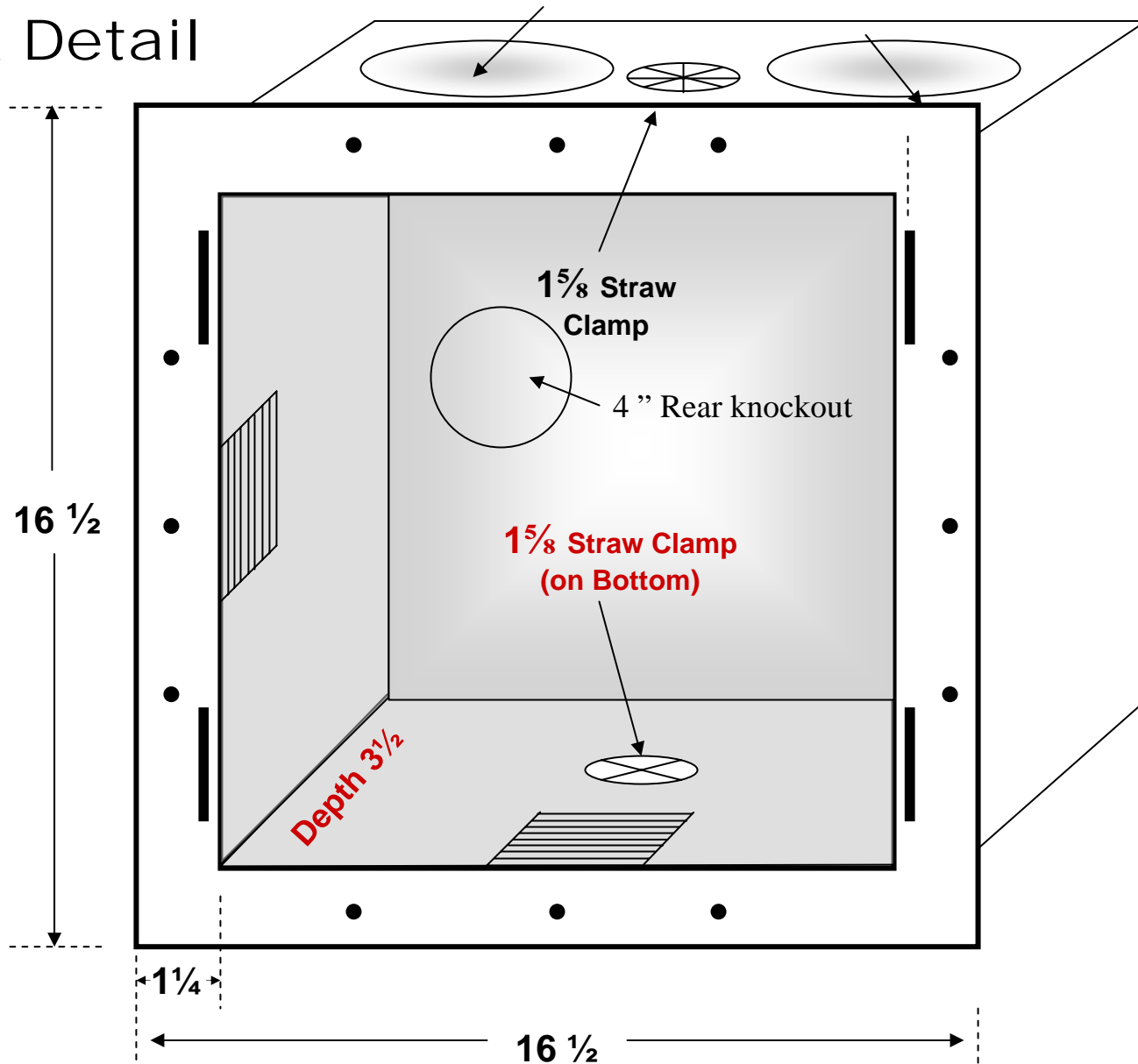

All dimensions in inches

4 Inch Box Trim Ring

Top Oval
Clearance
Notches

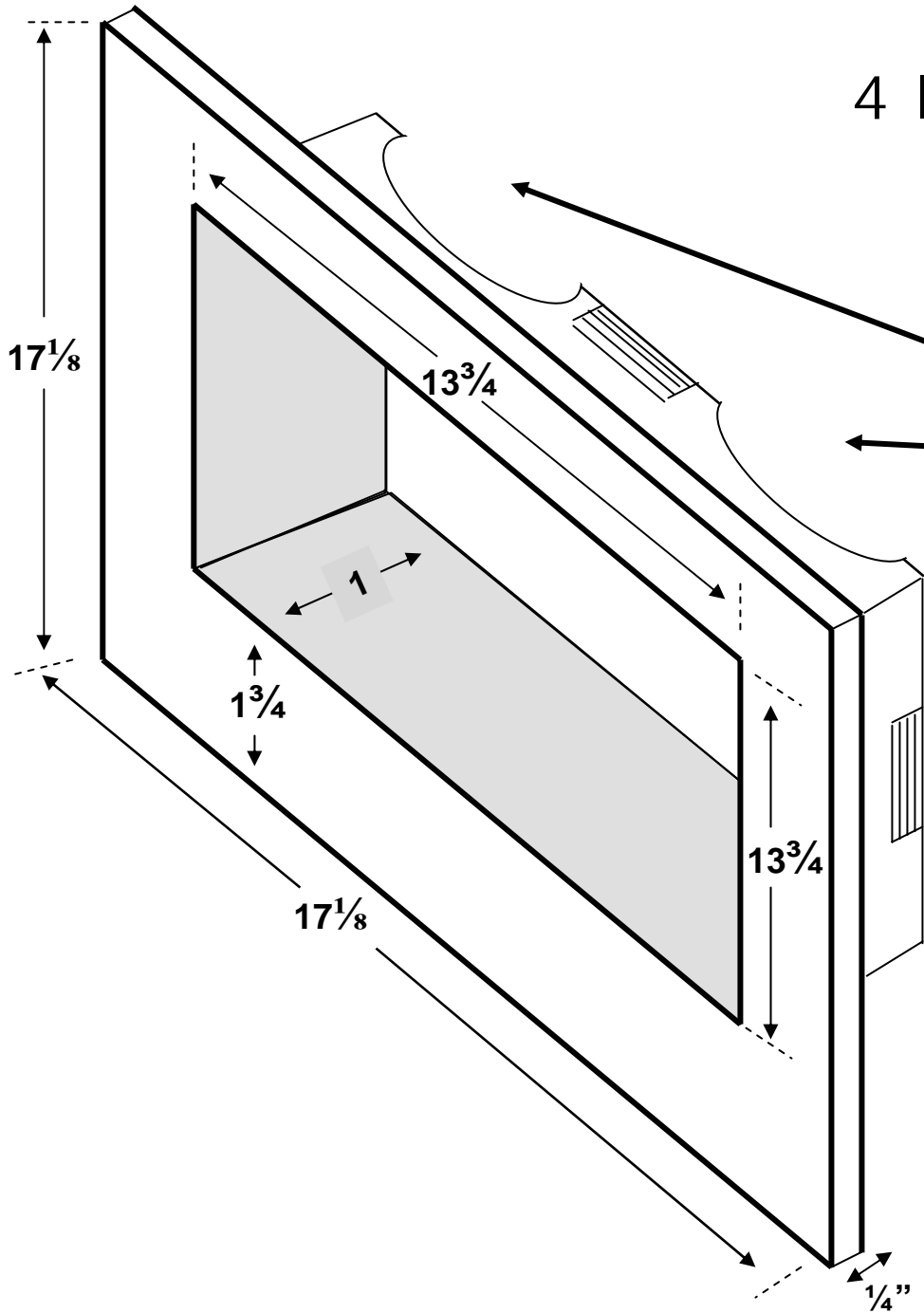

Installation Detail

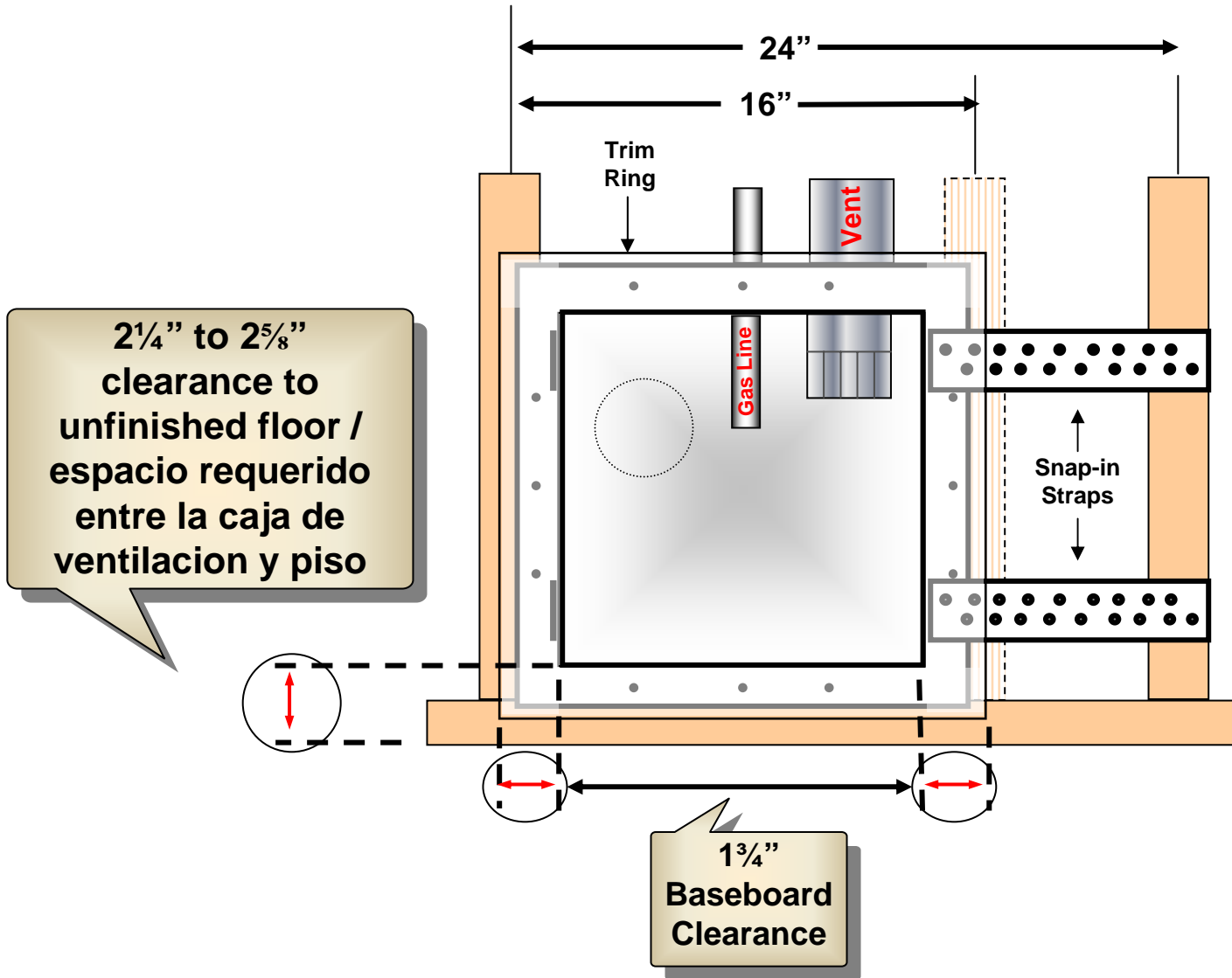

Specifications and Scope of Work

Builder Specification Wording for HVAC

“Recessed Dryer Vent Box with Snap on Trim Ring
Manufactured by Construction Solutions DBX1000”

Architectural Technical Specifications for DBX 10.01 (4” Construction)

Model Number DBX1000 Dryer Vent Box (4” Construction) by
Construction Solutions

Made of High Impact Polystyrene which Meets UL Standards for
94HB Flammability Testing and is recognized by Underwriters
Laboratories Inc. Representative samples of this component have
been evaluated by UL and meet applicable UL requirements.
Provide a 16” or 24” on center stud bay with 2 X 6 or 2 X 4 wall
structure.

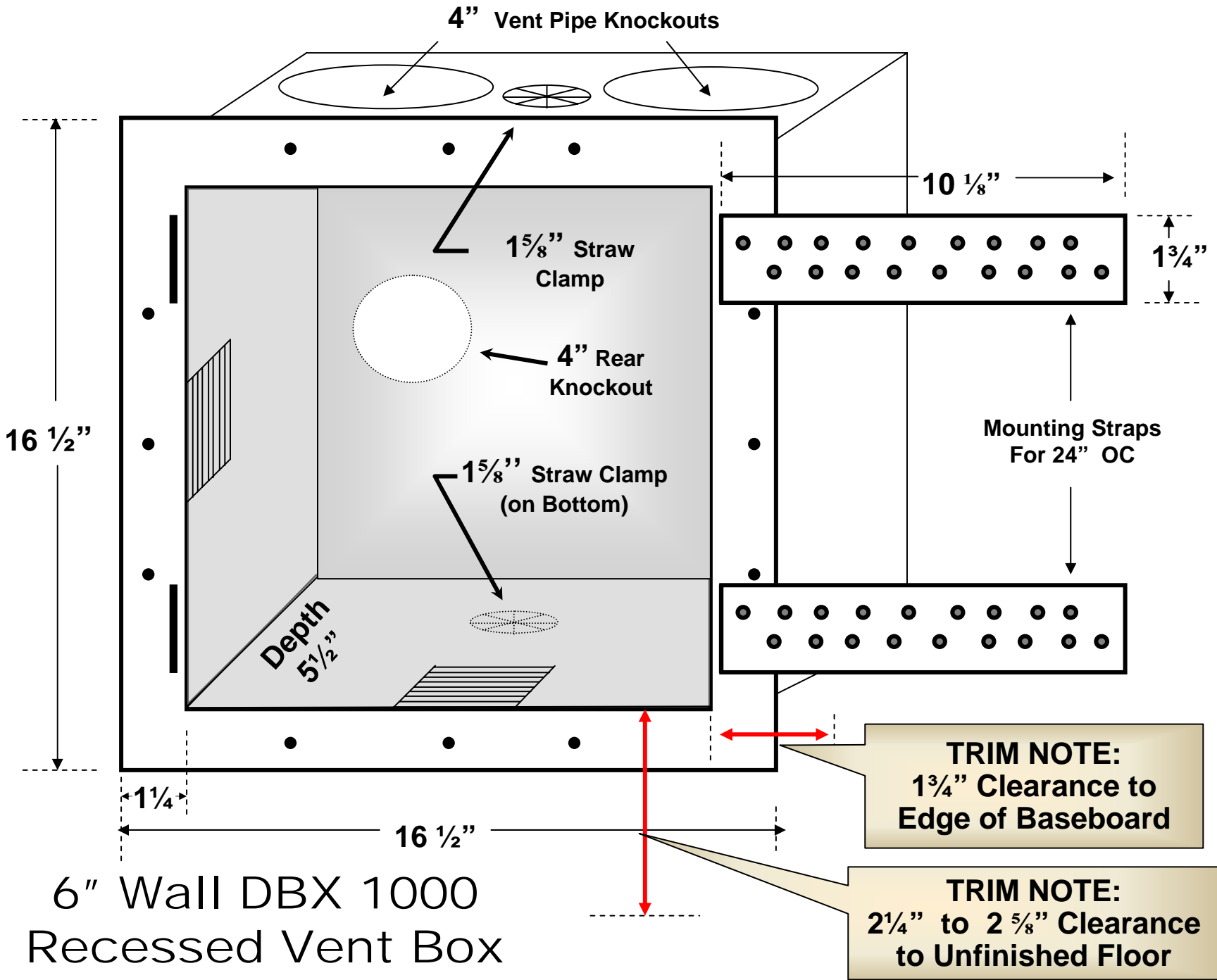

6" Inch Box Universal Trim Ring

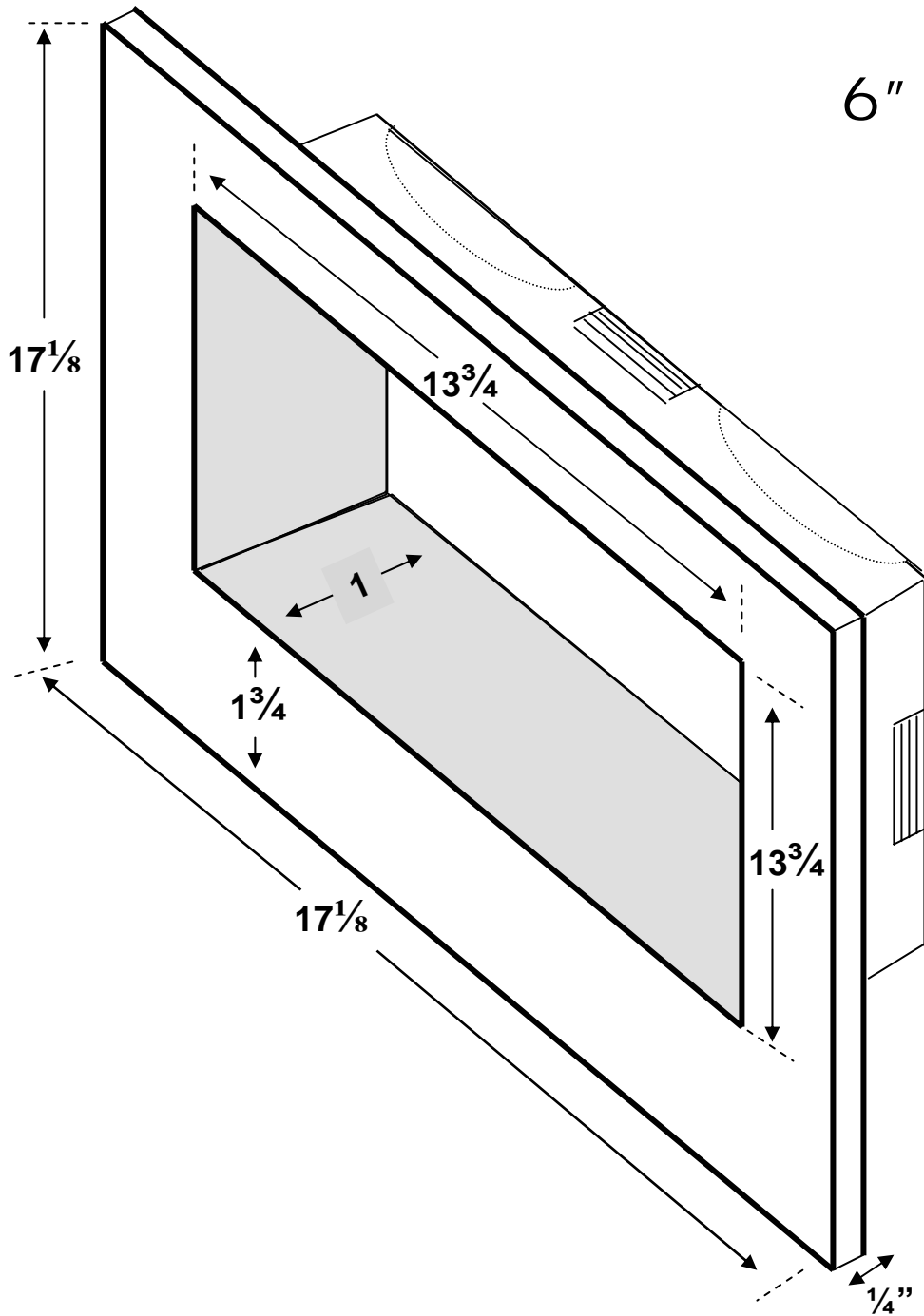

Installation Detail

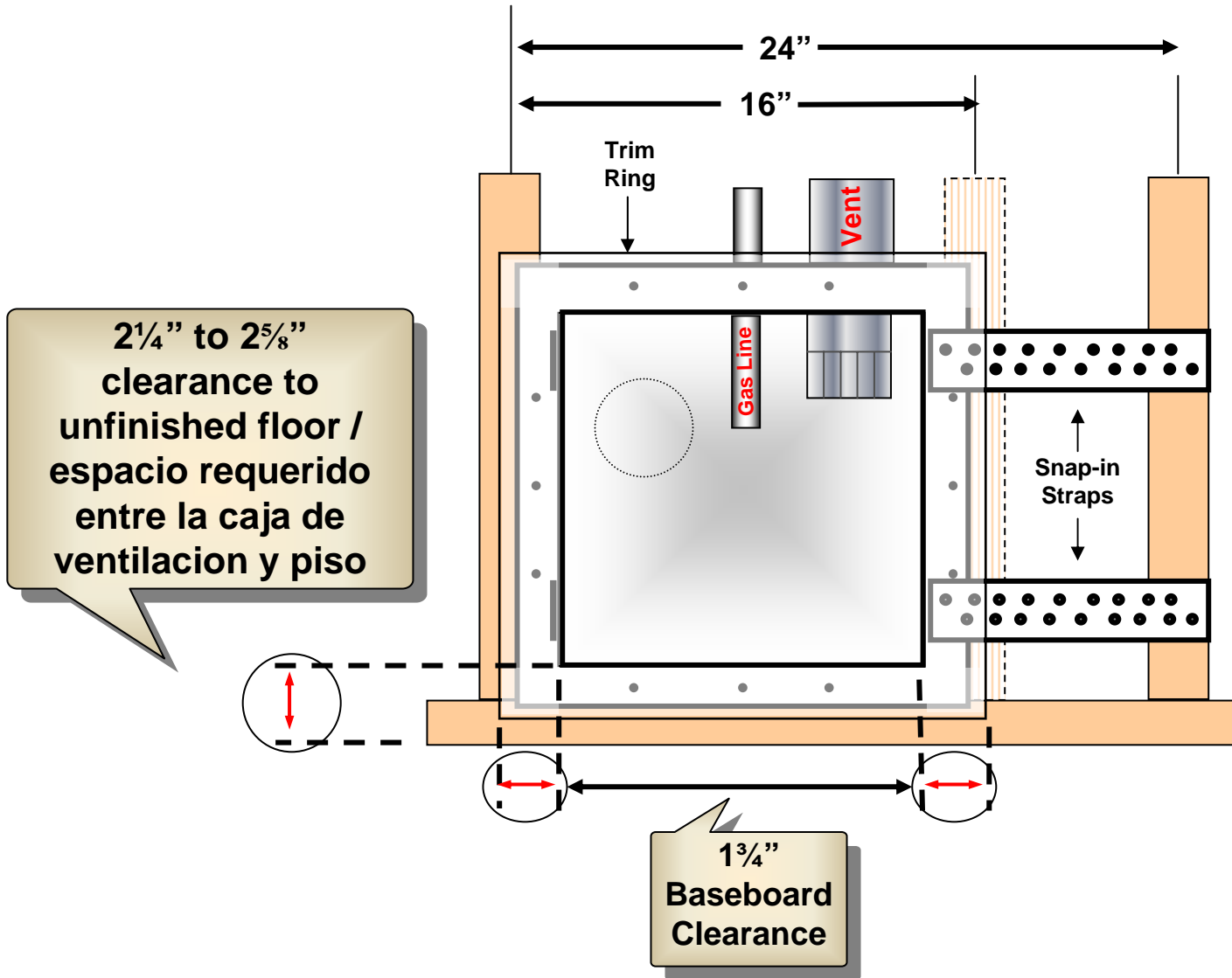

Specifications and Scope of Work

Builder Specification Wording for HVAC

“Recessed Dryer Vent Box with Snap on Trim Ring
Manufactured by Construction Solutions DBX1000”

Architectural Technical Specifications for DBX 5.01 (6” Construction)

Model Number DBX1000 Dryer Vent Box (6” Construction) by Construction Solutions

Made of High Impact Polystyrene which Meets UL Standards for 94HB Flammability Testing and is recognized by Underwriters Laboratories Inc. Representative samples of this component have been evaluated by UL and meet applicable UL requirements. Provide a 16” or 24” on center stud bay with 2 X 6 or 2 X 4 wall structure.