



22,000-25,000 BTU/HR Heater For:

- *Garages / Workshops*
- *Barns / Utility Buildings / Storage Sheds*
- *Animal Pens / Stalls*
- *Loading Docks*
- *Building Construction Sites*
- *Doorways / Ramps For Snow Prevention*

America's Most Complete Line Of Infrared Heaters!

HIGHLY EFFICIENT AND COST EFFECTIVE RADIANT HEAT.

- **Efficient Infrared Heat** - Directly heats people and objects which in turn heats surrounding air to desired temperature.
- **Economical** - No electricity required
- **Instant Heat** - Includes adjustable thermostat for individually controlled warmth
- **Large Capacity** - Heats 500-600 sq. ft. (2½ car garage)
- **Convenient** - Easy to operate and install
- **Quiet, Clean, Odor-Free Operation** - propane or natural gas
- **Ships Complete In Package For Easy Installation**
- **Includes Wall Louver For Fresh Air Intake**
- **Maintenance Free** - No moving parts to service
- **CSA Certified**
- **Limited 1 Year Warranty** - On gas control
- **Limited 5 Year Warranty** - On burner

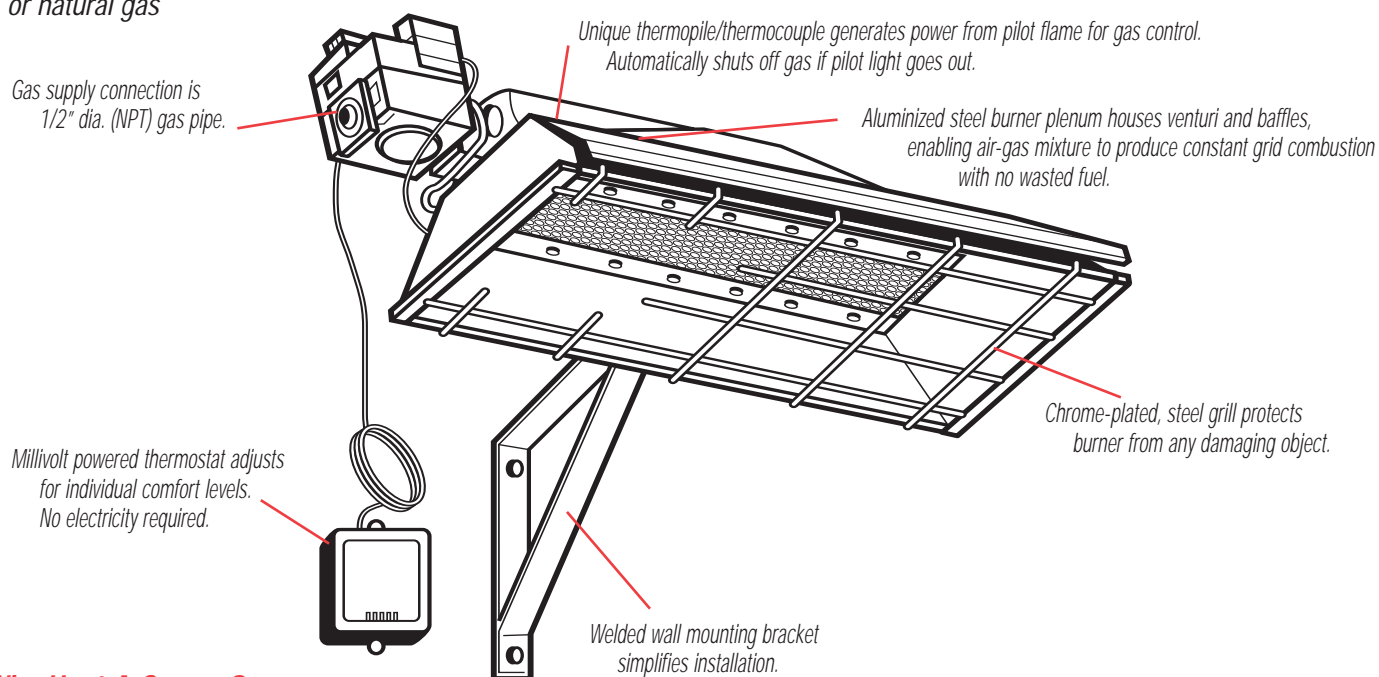

Why Heat A Garage?

- There are over 40 million single family residential garages in the U.S.
- A typical 2 car garage represents approximately 20% of the usable space in an average home
- Garages are the most under-utilized space in most climates during the winter months
- 55% of all homes have natural gas
- Cold garage temperatures may affect vehicles and plumbing
- A heated garage can be used for DIY Auto / Mechanical Maintenance / Workshop / Hobby Activities / Recreation (exercise equipment, table tennis, etc.) / Pet Comfort / Laundry



CSA Certified

SPECIFICATIONS & TECHNICAL DATA

MODEL NUMBER	BTU/HR. RATING		NORMAL MOUNTING POSITION	MOUNTING CLEARANCE TO COMBUSTIBLES				REFLECTOR DIMENSIONS L x W x H (INCHES)	TOTAL DIMENSIONS L x W x H (INCHES)	SHIPPING WEIGHT (LBS)	GAS INLET	MANIFOLD PRESSURE
	NATURAL GAS	PROPANE		TOP	SIDE	BACK	BELOW					
HS22L Stock Number: F125545	-	22,000*	30°	14"	16"	12"	48"	26½ x 11¾ x 3¼	29¾ x 12¼ x 7	25	½"	10"
HS25N Stock Number: F125444	25,000*	-	30°	14"	16"	12"	48"	26½ x 11¾ x 3¼	29¾ x 12¼ x 7	25	½"	6"

* Ratings shown are for elevations up to 2,000 feet. (In Canada, refer to rating tag.) For elevations above 2,000 feet, ratings should be reduced at the rate of 4% for each 1,000 feet above sea level or as specified by local authority having jurisdiction.

DO NOT use this in sleeping quarters, mobile homes, or recreational vehicles.