

BAROMETRIC DRAFT CONTROLS

Model: Type M



READ THESE INSTRUCTIONS CAREFULLY AND COMPLETELY BEFORE PROCEEDING WITH THE INSTALLATION.

This device **MUST** be installed by a qualified agency in accordance with the manufacturer's installation instructions. The definition of a qualified agency is: any individual, firm, corporation or company which either in person or through a representative is engaged in, and is responsible for, the installation and operation of HVAC appliances, who is experienced in such work, familiar with all the precautions required, and has complied with all the requirements of the authority having jurisdiction.

Please retain these instructions after installation.

Installed By: _____ Phone: _____ Installation Date: _____



FIELD CONTROLS

www.fieldcontrols.com

CHOOSING THE LOCATION

The best location for a draft control is on the side of a horizontal pipe. Choose the best which space will permit. (See Figures 1 & 2)

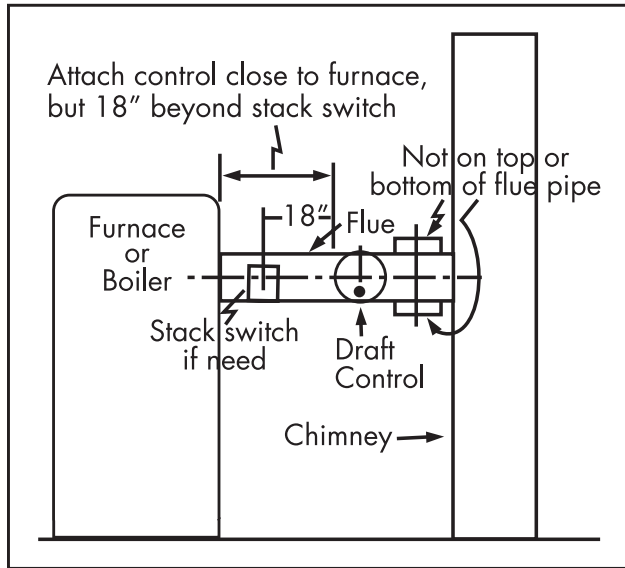

Figure 1

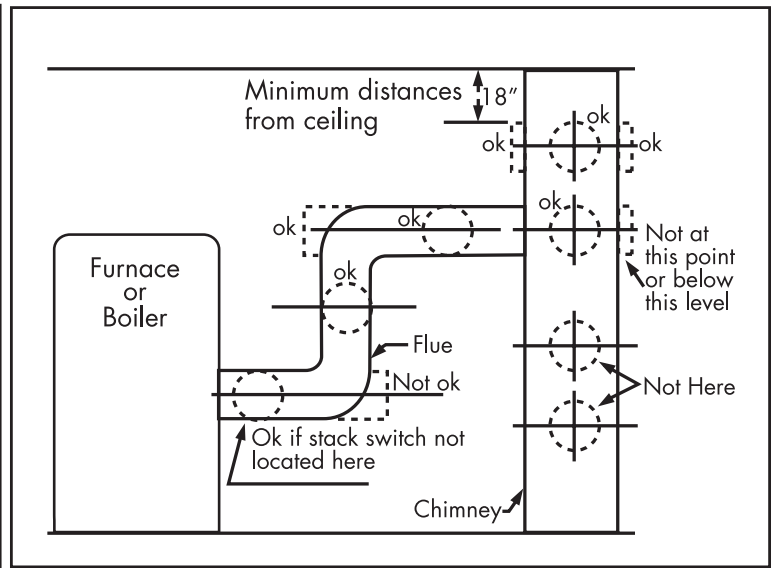

Figure 2

INSTALLATION

Bolt collar together before attaching it to the flue pipe or breeching. (See Figure 3) Squeeze and shape the collar of the draft control with the hands, if necessary, so that it will fit snugly on the flue, especially if the flue is out of round or a different size than the draft control. (See Figure 4) Then hold the collar against the flue in the EXACT position and mark the outline of the collar on the flue by means of a pencil or scratch pin. Cut a hole in the flue about half an inch smaller than the marks, if the material of which the flue is made is not heavier than 18 or 20 gauge.

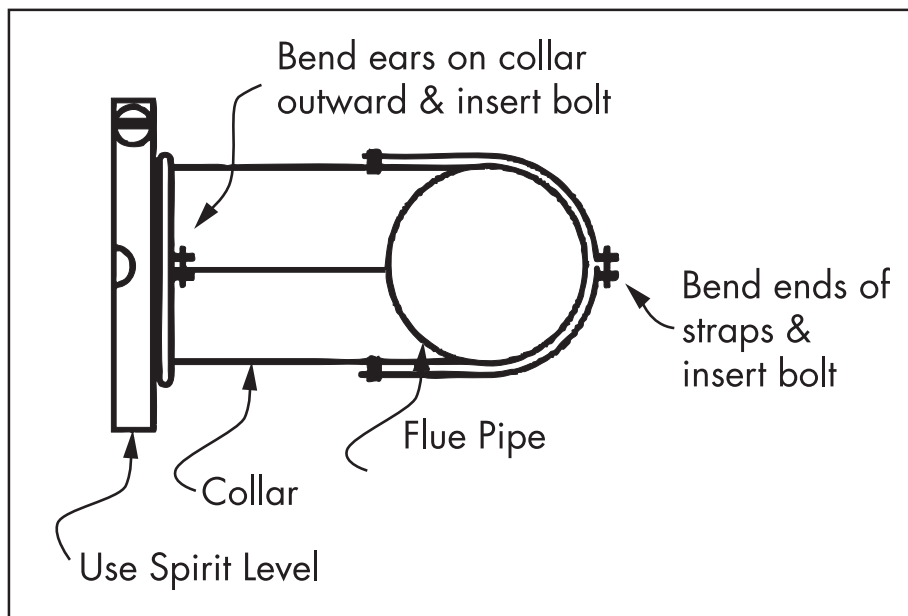

Figure 3

Then cut a series of short slits (about $\frac{3}{8}$ " or $\frac{1}{2}$ " deep) around the edges of the opening. After the collar is strapped on the flue the cut edges can be bent outward into the collar and thus make a better joint. WHEN FINISHED, THE OPENING INTO THE FLUE MUST BE FULL SIZE OF THE COLLAR OF THE DRAFT CONTROL. If flue pipe or breeching is made of material too heavy to bend out into collar, the opening into the breeching must be within $\frac{1}{4}$ " of the same diameter as the collar.

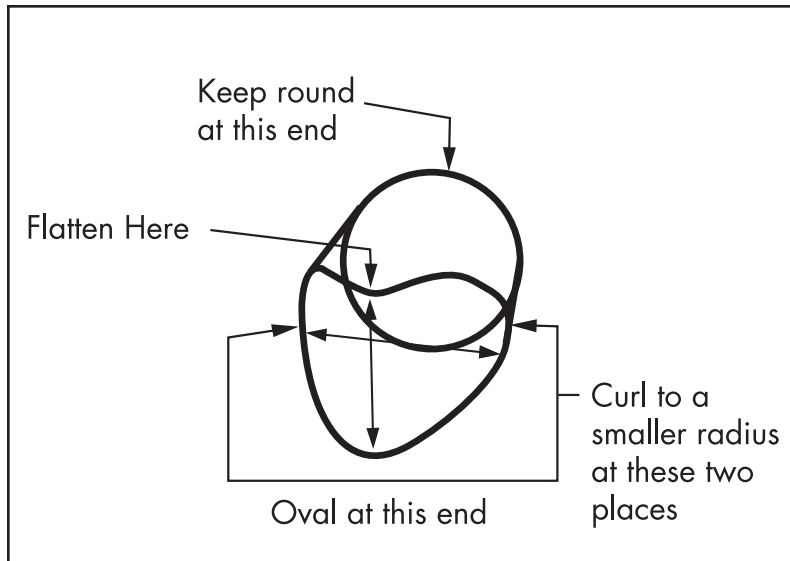

Figure 4

Strap the collar to the flue pipe and place the draft control into the collar, fastening it there by tightening the clamping screws in the collar. Support the draft control by means of a wire or strap from the ceiling as illustrated. (See Figure 5)

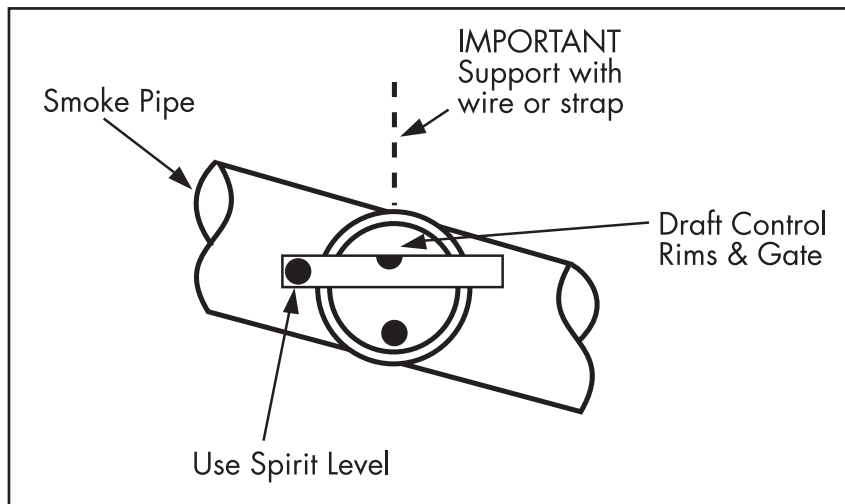

Figure 5

Use a spirit level to make sure that the control does not lean forward or backward but instead is plumb in both directions, regardless of whether the flue or breeching is horizontal, vertical, or sloping.

ADJUSTING THE CONTROL

Set the control to maintain as low a draft as will give good combustion and meet the requirements for heat. Screw the weight on the front of the control so that it moves outward (towards you as you face the front of the control) to increase the draft. Screw the weight on the front so that it moves inward if a lower draft is required. Please note that the 6" to 12" controls, inclusive, are set at the factory to maintain approximately .06" draft in the flue pipe. If this does not provide the proper draft, screw the weight inward or outward.

IMPORTANT: Don't change positions of weights on rear of gate. Except on 6" size, remove bolt and nut in upper part of gate if furnace or boiler is coal fired. Leave bolt alone if heating with oil. Bolt is identified by small decal with red arrow. On 6" size, follow directions on green card.

OIL BURNERS

After the fire has been operating long enough to thoroughly warm the heating plant, the draft may be set. The burner must be running when the adjustment of the control is made. To obtain best efficiency it is advisable that both draft, CO₂ and flue gas temperature readings be taken, as the draft control must be adjusted in combination with the oil burner fan which in turn is adjusted according to the rate of oil feed. A change in fan pressure may necessitate a change in the adjustment of the draft control.

Use a draft gauge and take readings over the fire through a small hole in the fire door or front of the furnace. For a domestic oil burner the over-fire draft should be approximately .02" to .03", although there are some makes of burners which require higher drafts. Consult with the burner manufacturer. There must always be enough draft so that the burner does not puff back into the room at the moment it starts, and there should be no objectionable smoke.

For larger plants the over-fire draft when the burner is operating probably should be from .04" to .06" or .07" if the burners are of the forced draft type. A large burner, depending entirely upon natural draft may require considerably higher drafts. It is essential that CO₂ readings be taken to determine the proper adjustments.

GAS-FIRED PLANTS

Domestic gas-fired furnaces or boilers often can be operated on over-fire drafts as low as .004" to .005". This usually means zero drafts at the smoke outlet of the furnace or boiler.

For commercial or industrial plants, follow the manufacturer's instructions. Draft controls having double swinging gates, known as Type MG regulators, are available for commercial and industrial gas installations. The gates of such controls open inward under normal up draft conditions, and outward in case of blocked flues or down drafts, thus relieving the internal pressures.

STOKERS

After the draft control is installed, start a fire. When the fuel bed reaches a normal depth, at least 6" to 10" deep, the draft can be set. The adjusting must be done while the stoker is running and its fan adjusted to approximately the correct setting.

When a draft gauge is available, the readings should be taken over the fire (that is, in the fire box or combustion chamber) through a small hole in the fire door. If the draft tube is inserted through a slide in door, it is best to insert the tube through a piece of paper to prevent a rush of air around the tube. For a domestic stoker in a home, the draft should be set at .04" OVER THE FIRE, with the STOKER ON, and for a somewhat larger plant .06" to .08" usually is sufficient. Have just enough draft so that at the moment the stoker starts, it does not gas or puff back into the room through cracks around the fire door (with the fire door closed). If there is objectionable smoke, increase draft slightly.

HAND-FIRED PLANTS

The controls from the 6" to the 12" size, inclusive, are pre-set at the factory for approximately the correct draft (.06") for the majority of installations. In most cases this will give sufficient draft for cold weather, with reasonably quick pickup after a banked period, which means the control is probably set correctly.

However, if it seems advisable to change the adjustment, a good fire should be burning and the plant operating. Close any check damper in the pipe and open wide the hand turn damper. If the plant overheats, screw the weight on the control inward so that the gate opens more. But if there is not enough heat, screw the weight outward, thus causing the gate to close more and maintain a stronger draft.

The 16" and larger regulators are not pre-set at the factory, and therefore have to be adjusted to suit the needs of the individual plant.

For larger plants, drafts over the fire (taken through openings in the fire doors, etc.) of .10" to .15" should be enough, and .20" should be the maximum. Greater economy will be obtained with lower drafts.

To check the fire or to bank it, close the ash pit door tightly. It is permissible to use a check or hand turn damper also, when banking the fire, should the ash pit doors fail to close tight enough. But if the ash pit draft doors fit well it is more simple to open or close the ash pit air register by degrees to obtain the heat desired at different times, rather than to change the settings at the smoke outlet of the furnace frequently.

When a thermostat and damper motor are used, install a Field Barocheck control instead of the standard unit.

LOCATION AND USE OF INTERNAL AND CHECK DAMPERS

With an oil burner, never use damper "A" (See Figure 6) or the check damper. Remove damper "A" and seal the check damper closed. If the draft developed in the chimney is very excessive, so that control cannot fully regulate it, damper "B" may be partly closed to supplement the control. But it must be securely locked so that it cannot block the flue passage too much and cause a deficiency of draft. For safety reasons, usually it is better to remove all internal dampers when an oil burner is installed. With a stoker, the same rules apply as with oil. For a hand fired coal burning plant, it is permissible to use damper "A" of the check damper when it is desired to bank the fire. The Field Barocheck combines the function of a check damper with that of a barometric control all in one unit. If the draft developed in the chimney is very excessive, damper "B" may be used by partly closing it, locking it there.

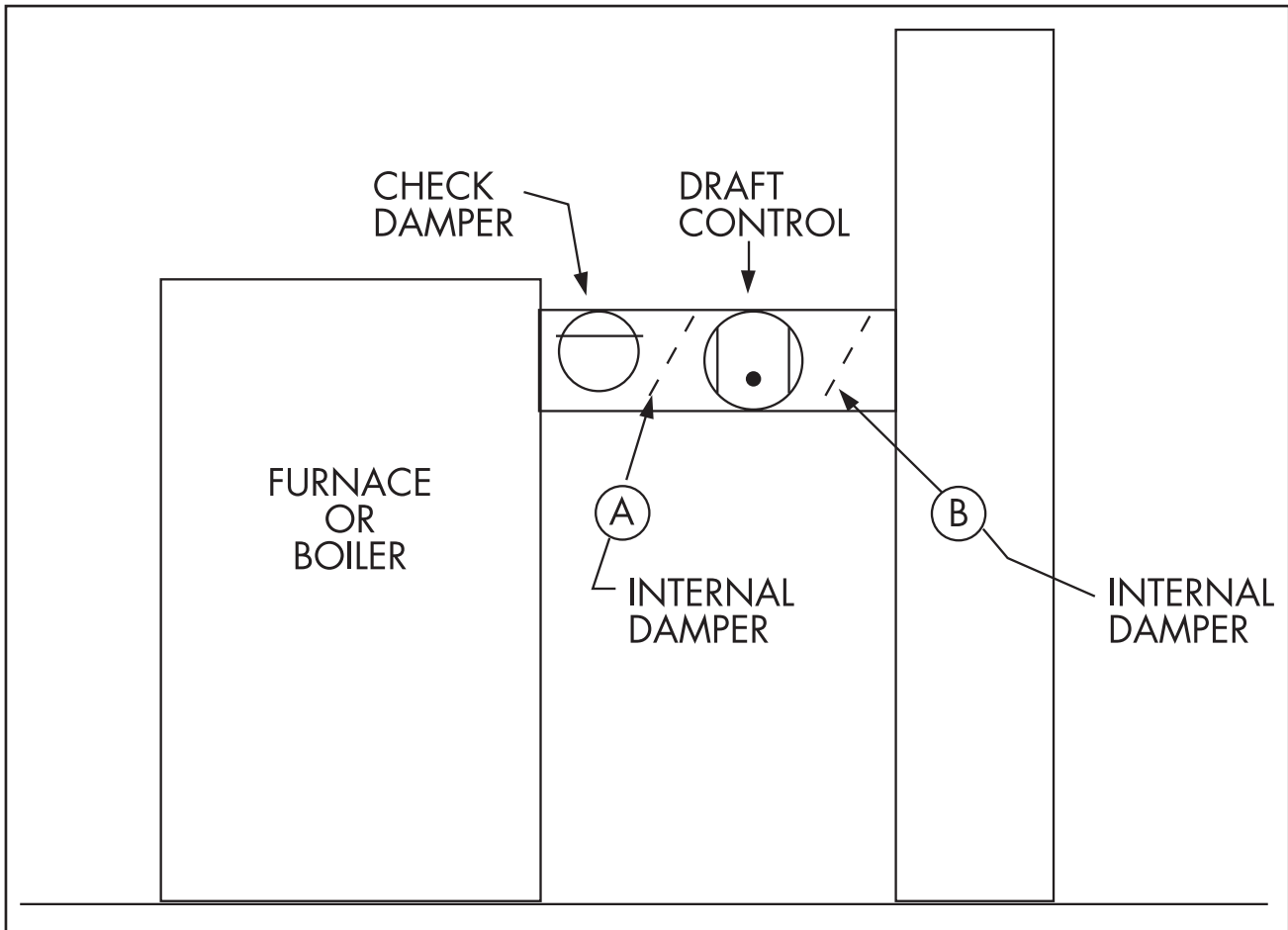

Figure 6

WARRANTY

For warranty about this or any Field Controls product, visit:
www.fieldcontrols.com/warranty



FIELD CONTROLS
Phone: 252.522.3031 • Fax: 252.522.0214
www.fieldcontrols.com