

PROJECT: _____	UNIT TAG: _____	QUANTITY: _____
REPRESENTATIVE: _____	TYPE OF SERVICE: _____	DATE: _____
ENGINEER: _____	SUBMITTED BY: _____	DATE: _____
CONTRACTOR: _____	APPROVED BY: _____	DATE: _____
	ORDER NO.: _____	DATE: _____



ALPHA2 15-55SF

Grundfos ALPHA2 pumps are high-efficiency circulators, designed for circulating liquids in heating systems, and for domestic hot-water recirculation. The pump features AUTOADAPT which automatically adjusts the pump to system demands for lowest energy consumption.

Note! Product picture may differ from actual product

Conditions of Service	Pump Data	Motor Data
Flow: _____	Maximum operating pressure: 10 bar	P1 max: 5 .. 45 W
Head: _____	Liquid temperature range: 2 .. 110 °C	Rated voltage: 115 V
Efficiency: _____	Maximum ambient temperature: 40 °C	Mains frequency: 60 Hz
Liquid: Water	Approvals: ETL, FCC, NSF	Enclosure class: IP42
Temperature: 60 °C	Pipe connection: 1 1/2	Insulation class: F
NPSH required: m	Product number: 99163937	Motor protection: NONE
Viscosity: _____		Thermal protection: ELEC
Specific Gravity: 0.985		

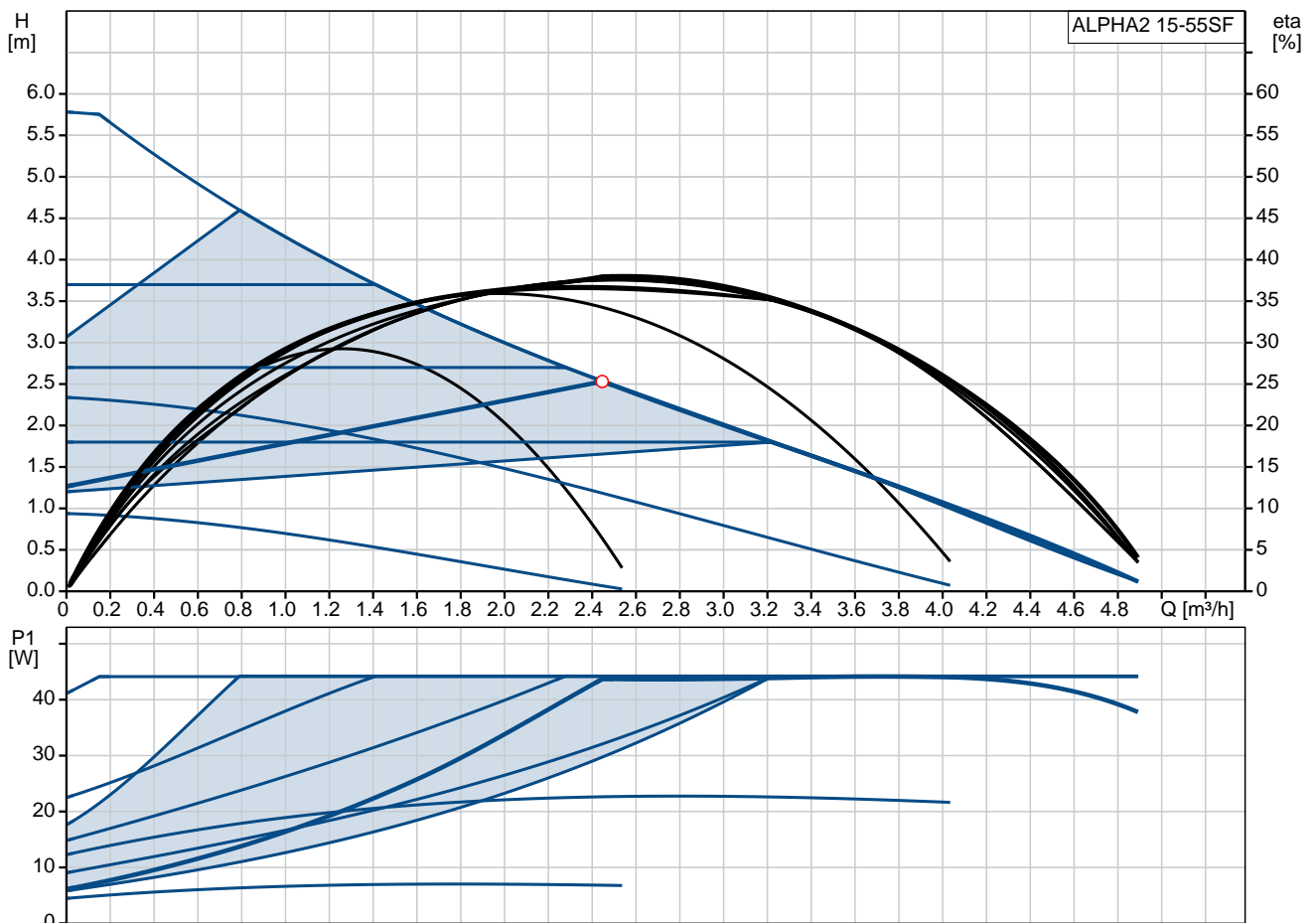

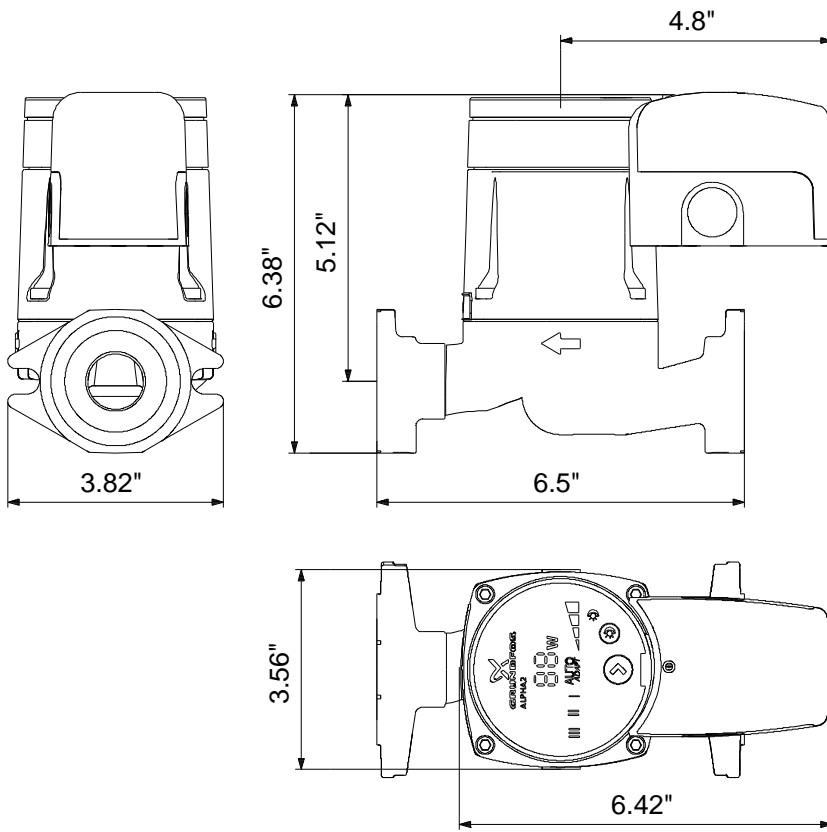

Materials:

Pump housing: Stainless steel
EN 1.4308
Impeller: Composite

Tender Text



Product No.: [99163937](#)

ALPHA2 15-55SF

GRUNDFOS ALPHA2

The next generation of energy efficient circulators.

Grundfos ALPHA2 is versatile and efficient whether you use one of its seven speed or pressure control settings or simply leave it on the factory setting AUTOADAPT™.

The ALPHA2 with its ECM motor design reduces energy consumption by 50%.

In AUTOADAPT mode, the pump will automatically analyze the heating system, find the optimum setting, continue to adjust its operation to changes in demand, ensuring the lowest possible energy consumption without sacrificing comfort.

Compact design

With the electronics integrated into the motor housing and standard 2-Bolt flange connection, installation into confined spaces and challenging applications are now possible.

The ALPHA2 materials and design resist blockage from magnetite and iron oxide particles found in closed hydronic systems.

ALPHA2 is complete with an integrated check-valve, foam insulation jacket, and nut captures for flanges. ALPHA2 comes in both cast iron and stainless steel models

Two options for power connections

The large LED display shows the current energy consumption in Watts and estimated flow in gallons per minute. For installation, you have the flexibility to use either our unique ALPHA Plug with line cord or the ALPHA2 with terminal box for conduit connections

One-touch operation

Simple push button control enables the ALPHA2 to be programmed in one of 3-constant speed, 3-constant pressure, or AUTOADAPT control modes. The current operating mode is always visible on the ALPHA2's LED display

LED Display

The easy-to-read LED display indicating power (Watts) consumption and flow (GPM) estimation.

Robust startup

Enables the ALPHA2 to continuously attempt to restart – indefinitely – in blocked rotor conditions

Liquid:

Pumped liquid: Water
Liquid temperature range: 2 .. 110 °C
Liquid temperature during operation: 60 °C
Density: 983.2 kg/m³

Technical:

TF class: 110
Approvals on nameplate: ETL, FCC, NSF

Materials:

Pump housing: Stainless steel
EN 1.4308
Impeller: Composite

Installation:

Range of ambient temperature: 0 .. 40 °C
Maximum operating pressure: 10 bar
Type of connection: GF
Pipe connection: 1 1/2
Pressure rating: PN 10
Port-to-port length: 165 mm

Electrical data:

Power input - P1: 5 .. 45 W
Mains frequency: 60 Hz
Rated voltage: 1 x 115 V
Maximum current consumption: 0.1 .. 0.65 A
Enclosure class (IEC 34-5): IP42
Insulation class (IEC 85): F

Others:

Net weight: 2.54 kg
Gross weight: 2.85 kg
Shipping volume: 7.14 m³

Position	Qty.	Description
	1	<p>ALPHA2 15-55SF</p>  <p>Product No.: 99163937</p> <p>GRUNDFOS ALPHA2 The next generation of energy efficient circulators.</p> <p>Grundfos ALPHA2 is versatile and efficient whether you use one of its seven speed or pressure control settings or simply leave it on the factory setting AUTOADAPT™.</p> <p>The ALPHA2 with its ECM motor design reduces energy consumption by 50%.</p> <p>In AUTOADAPT mode, the pump will automatically analyze the heating system, find the optimum setting, continue to adjust its operation to changes in demand, ensuring the lowest possible energy consumption without sacrificing comfort.</p> <p>Compact design With the electronics integrated into the motor housing and standard 2-Bolt flange connection, installation into confined spaces and challenging applications are now possible.</p> <p>The ALPHA2 materials and design resist blockage from magnetite and iron oxide particles found in closed hydronic systems.</p> <p>ALPHA2 is complete with an integrated check-valve, foam insulation jacket, and nut captures for flanges. ALPHA2 comes in both cast iron and stainless steel models</p> <p>Two options for power connections The large LED display shows the current energy consumption in Watts and estimated flow in gallons per minute. For installation, you have the flexibility to use either our unique ALPHA Plug with line cord or the ALPHA2 with terminal box for conduit connections</p> <p>One-touch operation Simple push button control enables the ALPHA2 to be programmed in one of 3-constant speed, 3-constant pressure, or AUTOADAPT control modes. The current operating mode is always visible on the ALPHA2's LED display</p> <p>LED Display The easy-to-read LED display indicating power (Watts) consumption and flow (GPM) estimation.</p> <p>Robust startup Enables the ALPHA2 to continuously attempt to restart – indefinitely – in blocked rotor conditions</p> <p>Liquid: Pumped liquid: Water Liquid temperature range: 2 .. 110 °C Liquid temperature during operation: 60 °C Density: 983.2 kg/m³</p> <p>Technical: TF class: 110 Approvals on nameplate: ETL, FCC, NSF</p>

Position	Qty.	Description
		<p>Materials:</p> <p>Pump housing: Stainless steel EN 1.4308</p> <p>Impeller: Composite</p> <p>Installation:</p> <p>Range of ambient temperature: 0 .. 40 °C Maximum operating pressure: 10 bar Type of connection: GF Pipe connection: 1 1/2 Pressure rating: PN 10 Port-to-port length: 165 mm</p> <p>Electrical data:</p> <p>Power input - P1: 5 .. 45 W Mains frequency: 60 Hz Rated voltage: 1 x 115 V Maximum current consumption: 0.1 .. 0.65 A Enclosure class (IEC 34-5): IP42 Insulation class (IEC 85): F</p> <p>Others:</p> <p>Net weight: 2.54 kg Gross weight: 2.85 kg Shipping volume: 7.14 m³</p>

99163937 ALPHA2 15-55SF 60 Hz

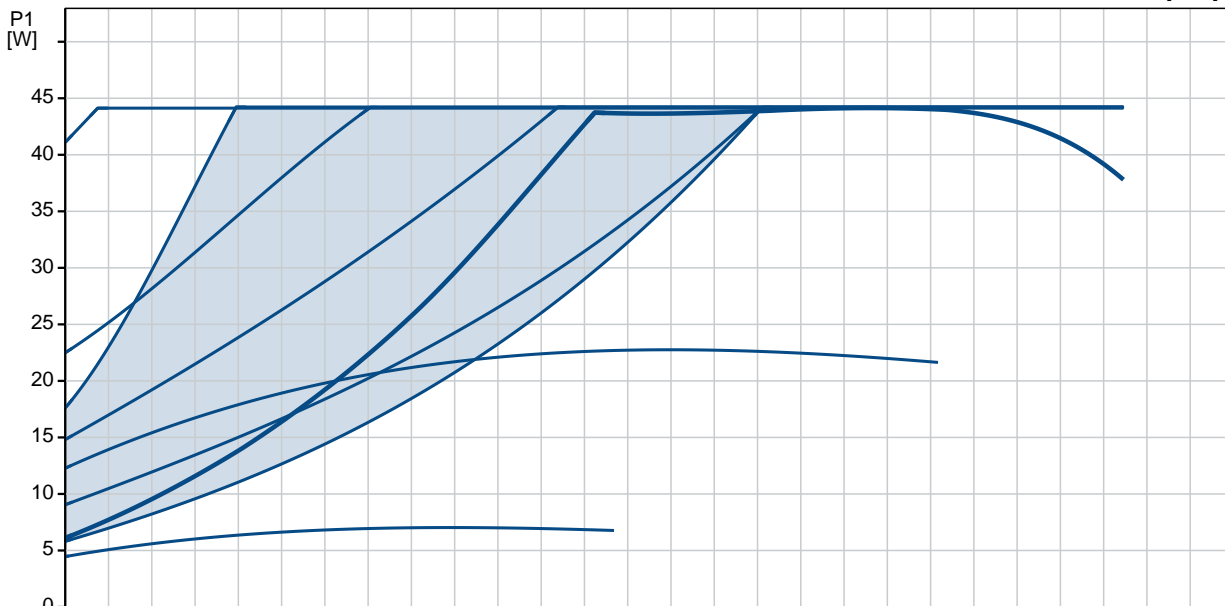
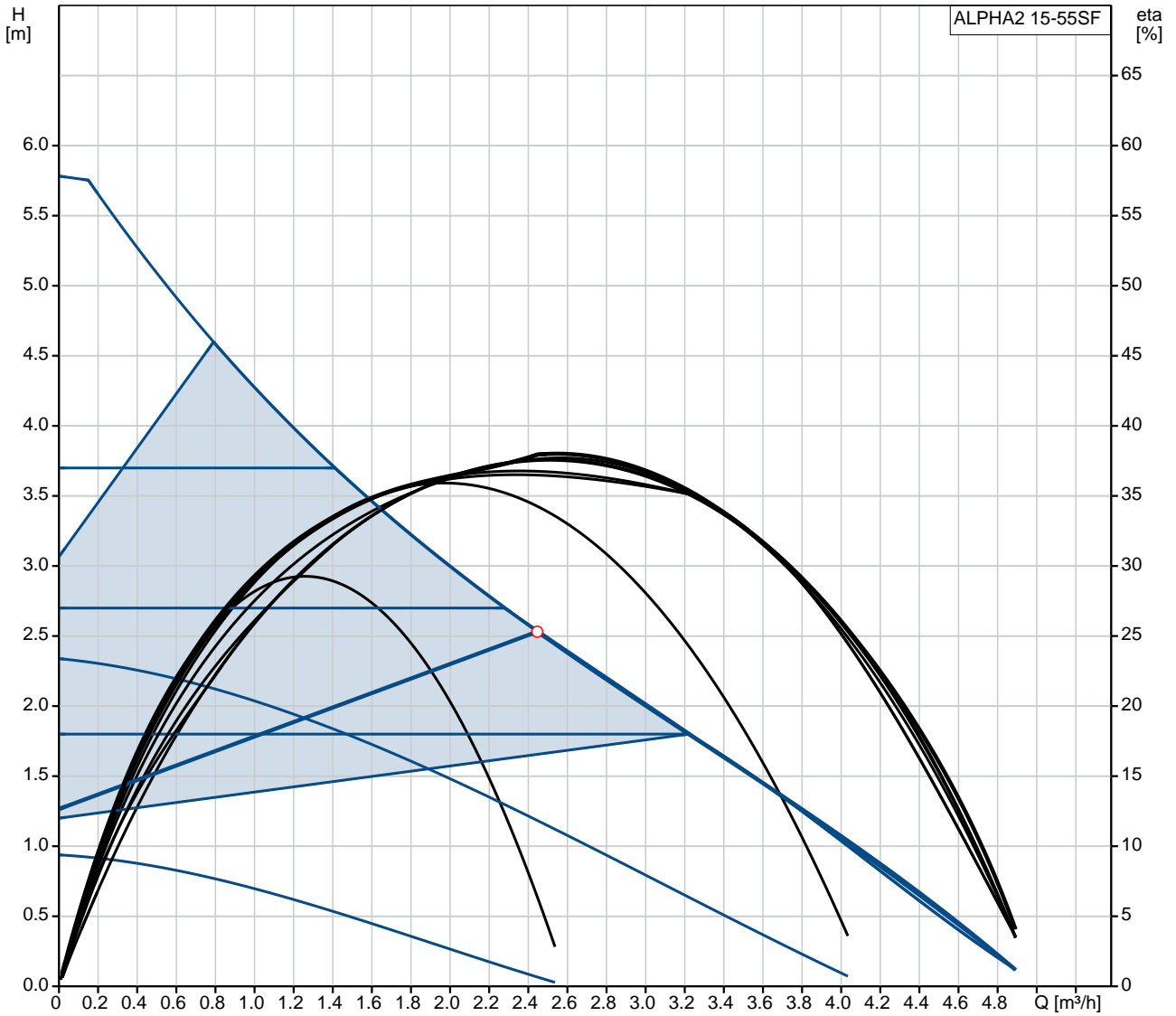

Description	Value
-------------	-------

General information:

Product name: ALPHA2 15-55SF
 Product No: 99163937
 EAN number: 5712607918767

Technical:

Head max: 55 dm
 TF class: 110
 Approvals on nameplate: ETL, FCC, NSF

Materials:

Pump housing: Stainless steel
 EN 1.4308
 Impeller: Composite

Installation:

Range of ambient temperature: 0 .. 40 °C
 Maximum operating pressure: 10 bar
 Type of connection: GF
 Pipe connection: 1 1/2
 Pressure rating: PN 10
 Port-to-port length: 165 mm

Liquid:

Pumped liquid: Water
 Liquid temperature range: 2 .. 110 °C
 Liquid temperature during operation: 60 °C
 Density: 983.2 kg/m³

Electrical data:

Power input - P1: 5 .. 45 W
 Mains frequency: 60 Hz
 Rated voltage: 1 x 115 V
 Maximum current consumption: 0.1 .. 0.65 A
 Enclosure class (IEC 34-5): IP42
 Insulation class (IEC 85): F
 Motor protec: NONE
 Thermal protec: ELEC

Controls:

Pos term box: 6H

Others:

Net weight: 2.54 kg
 Gross weight: 2.85 kg
 Shipping volume: 7.14 m³
 Sales region: USA

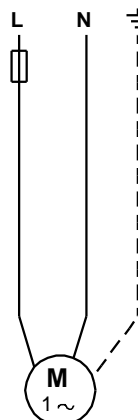
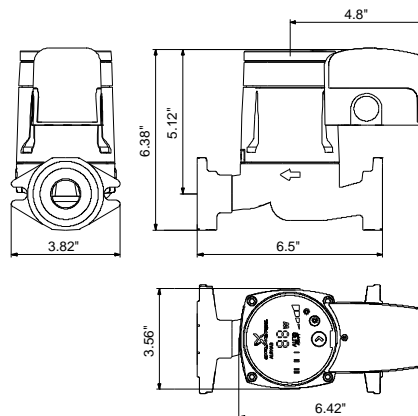
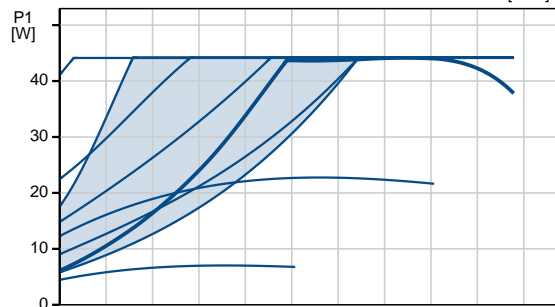
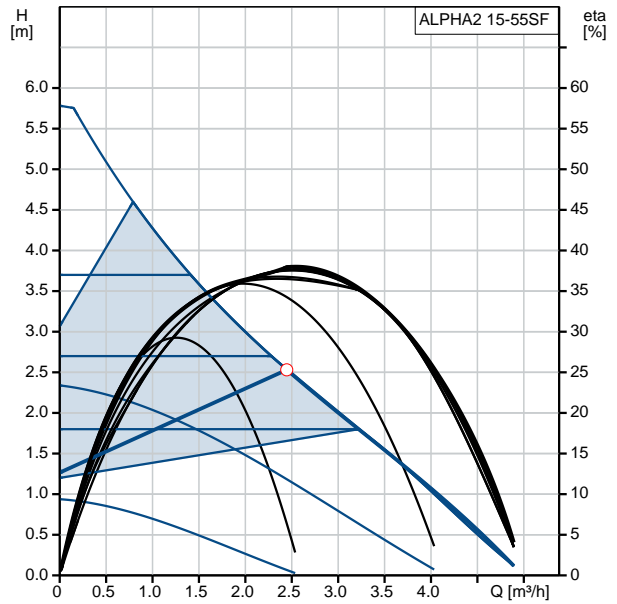

99163937 ALPHA2 15-55SF 60 Hz

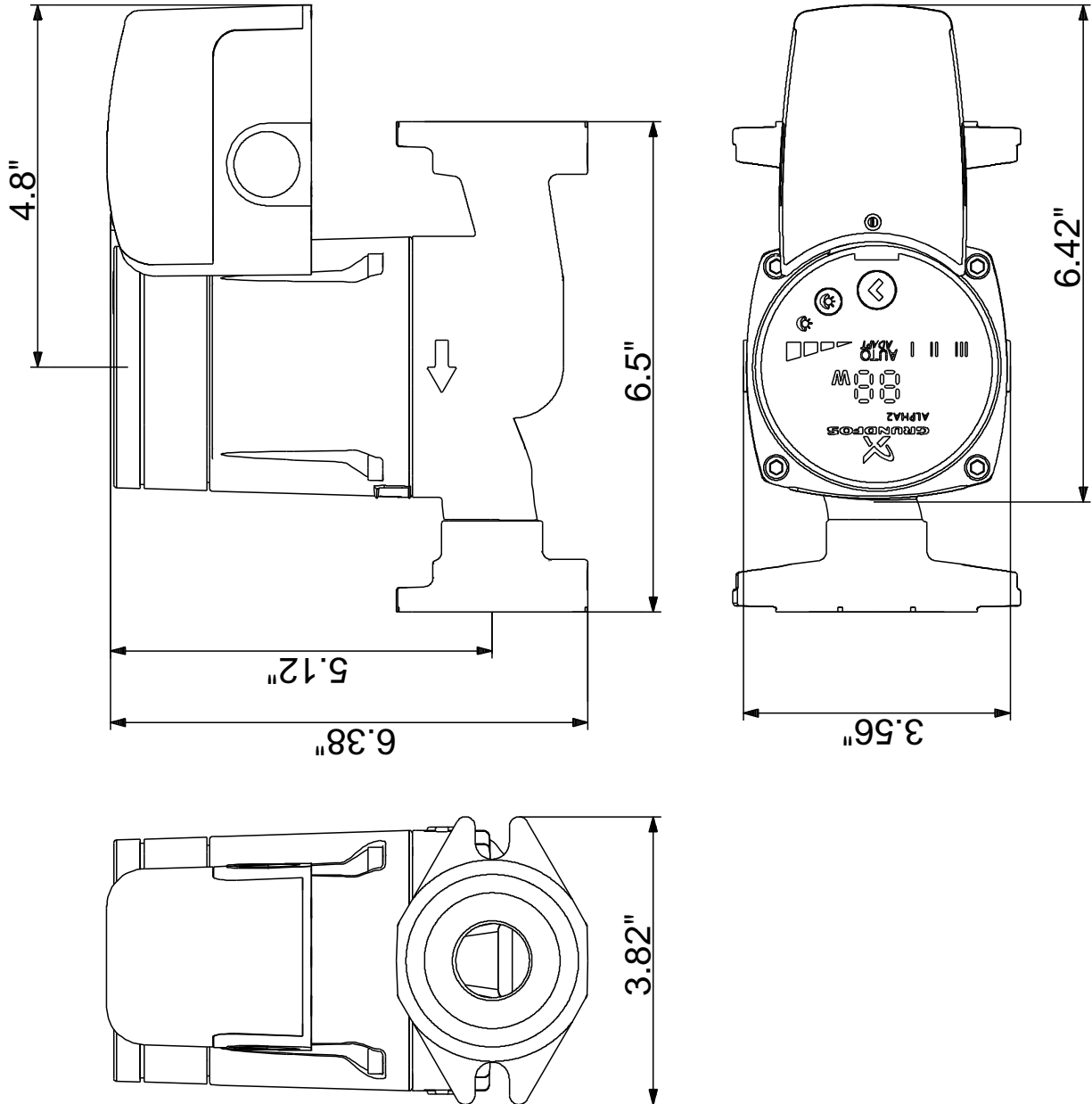

Note! All units are in [mm] unless others are stated.
Disclaimer: This simplified dimensional drawing does not show all details.

99163937 ALPHA2 15-55SF 60 Hz

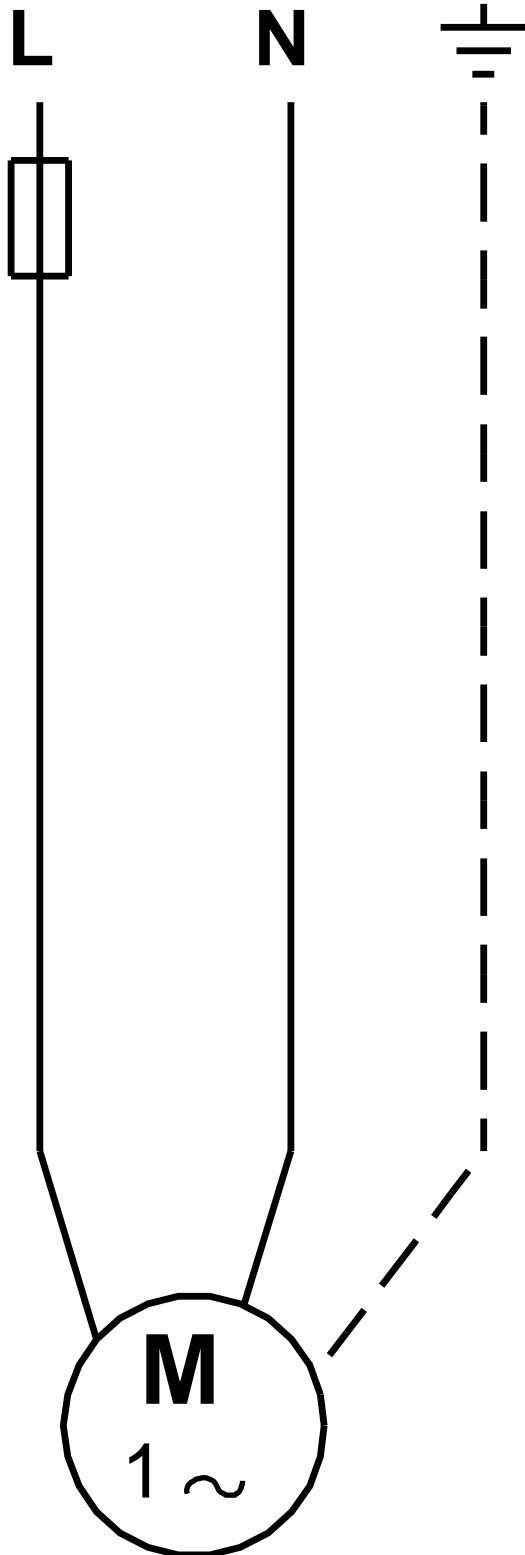

Note! All units are in [mm] unless others are stated.



Company name:

Created by:

Phone:

Date: 21/02/2018

Order Data:

Product name: ALPHA2 15-55SF

Amount: 1

Product No: 99163937

Total: Price on request



Company name:

Created by:

Phone:

Date:

21/02/2018

Parts list ALPHA2 15-55SF, Product No. 99163937

Valid from 19.4.2017 (1716)

Pos	Description	Annotation	Classification Data	Part no.	Qty.	Unit
	Gasket				2	pcs