

**Alternate Steps 4a or 5a below are for kits that include the breaker assembly attached to the barrier assembly at the factory ONLY:**

For QR breaker kits used in Revised P1 panels, part numbers are similar to those below:

MBKQR1\*\*\*A: replace “\*\*\*” with breaker amperage: 100,125,150,175,200 or 225

MBKQR3\*\*\*A: replace “\*\*\*” with breaker amperage: 100,125,150,175,200 or 225

MBKQR1\*\*\*HA: replace “\*\*\*” with breaker amperage: 100,125,150,175,200 or 225

MBKQR3\*\*\*HA: replace “\*\*\*” with breaker amperage: 100,125,150,175,200 or 225

#### **Alternate Step 4a:**

Locate the breaker and barrier assembly at the main or subfeed end of the panel.

**Note:** If bus holes do not align with the strap holes, loosen screws (Item 7) approximately one turn then proceed. Ensure the straps are properly aligned with the panel bus.

Secure the straps to the phase bus with 1/4”-20 SEMS screws (Item 5). Then secure the barrier to the base rails with #10-24 thread-forming screws (Item 6). Do not tighten at this time.

#### **Alternate Step 5a:**

Visually inspect to ensure all fasteners are in place, then tighten screws to torque values provided on the chart included on Page 2, or on the label on the back side of the deadfront. Tighten in this order: Item 6 to baserails, Item 5 to phase bus and finally Item 7 to breaker straps (verify torque even if not loosened earlier).

**Return to Step 6 on Page 3 and continue....**

These instructions do not purport to cover all details or variations in equipment, or to provide for every possible contingency to be met in connection with installation, operation or maintenance. Should further information be desired or should particular problems arise, which are not covered sufficiently for the purchaser's purposes, the matter should be referred to the local Siemens sales office. The contents of this Instruction manual shall not become part of or modify any prior or existing agreement, commitment or relationship. The sales contract contains the entire obligation of Siemens. The warranty contained in the contract between the parties is the sole warranty of Siemens. Any statements contained herein do not create new warranties or modify the existing warranty.

Trademarks - Unless otherwise noted, all names identified by ® are registered trademarks of Siemens AG or Siemens Industry, Inc. The remaining trademarks in this publication may be trademarks whose use by third parties for their own purposes could violate the rights of the owner.

# SIEMENS

## **P1-250 Panelboard Kit MBKQR1A & MBKQR3A for 225A MAX QR Main/Subfeed Breaker & also for P1-400 Subfeed (for use in Revised P1 Panelboards ONLY)<sup>1</sup>**

**Installation  
Instructions**

**Also for QR  
breaker kits  
with breaker  
INCLUDED.  
Part numbers:  
MBKQR1\*\*\*A  
MBKQR3\*\*\*A  
MBKQR1\*\*\*HA  
MBKQR3\*\*\*HA**

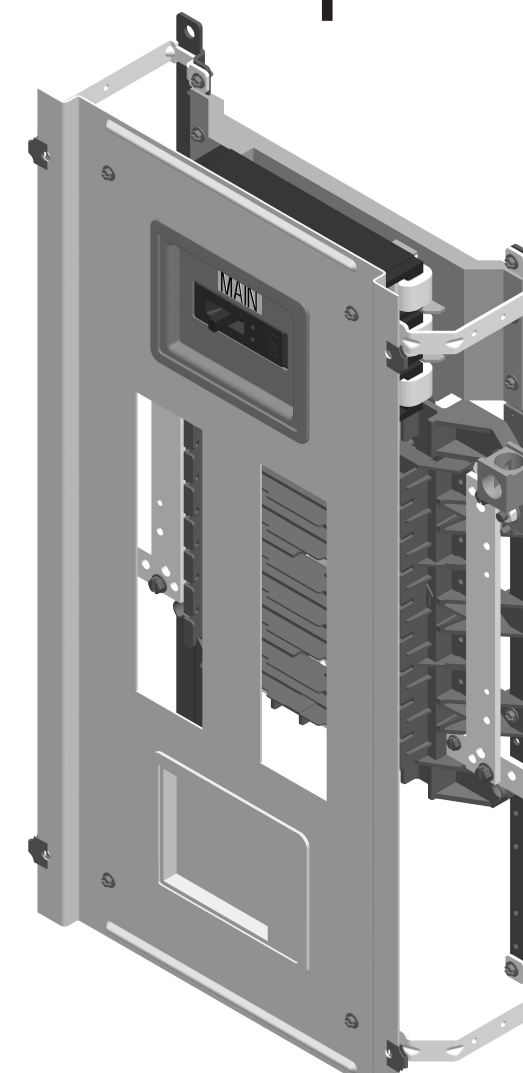

<sup>1</sup> To confirm, note the part number of the panel (marked on the interior label). If it ends in an “N” or a “T” it is a “Revised P1” and is compatible with this kit. (For example: P1E42MC250A is an Original P1; P1E42MC250AT is a Revised P1)

**3-PHASE  
P1-250**

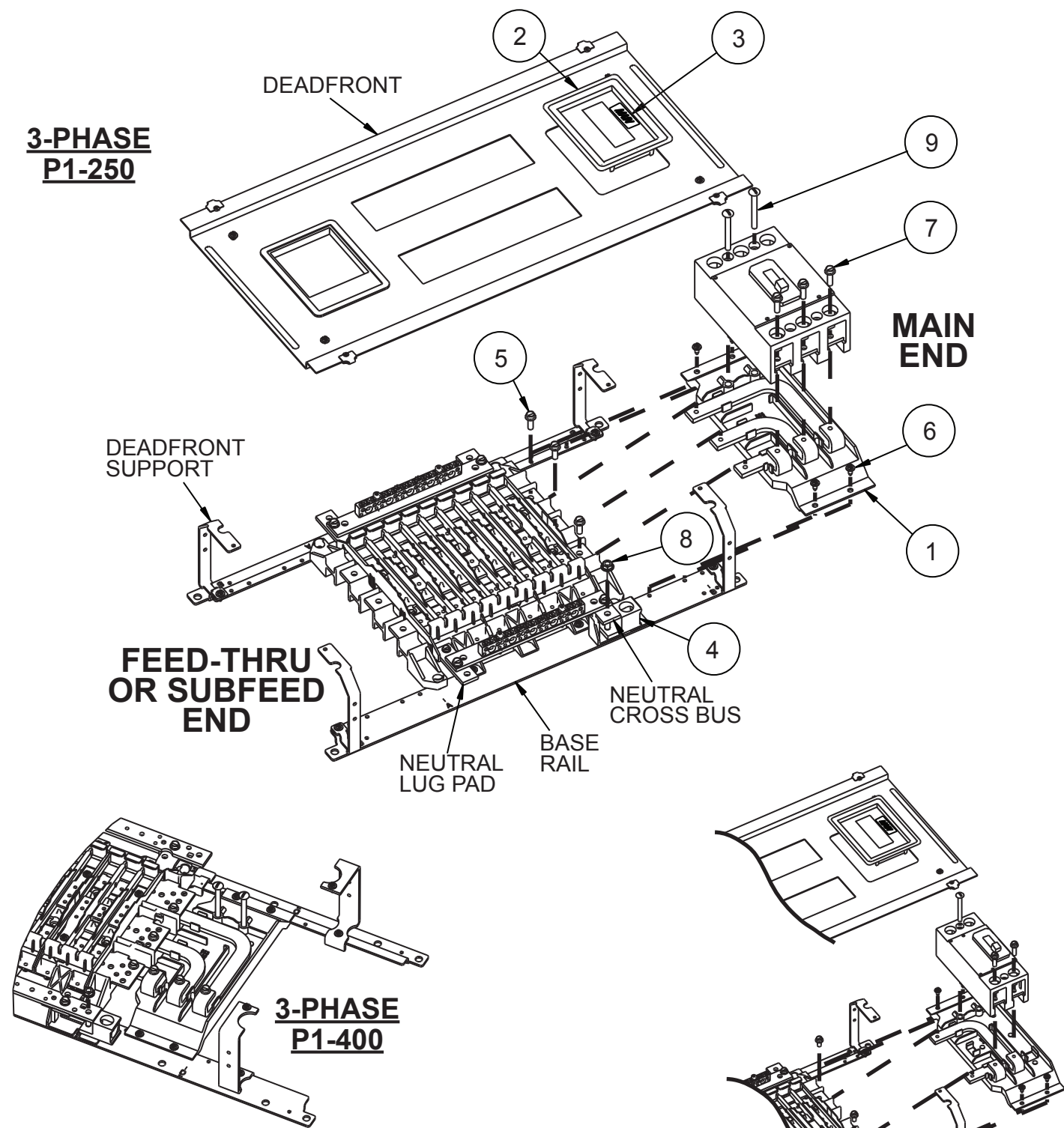

**THIS KIT CONTAINS THE FOLLOWING ITEMS:**

ITEM	DESCRIPTION	QTY	TORQUE
1	BREAKER BARRIER ASSEMBLY	1	N/A
2	BREAKER ESCUTCHEON	1	N/A
3	MAIN LABEL	1	N/A
4	NEUTRAL LUG ASSEMBLY	1	N/A
5	1/4"-20 x 1/2" HEX HEAD SEMS* ASSEMBLY SCREW	**	72 lb-in
6	#10-24 x 7/16" SLOTTED HEX WASHER THREAD-FORMING SCREW	4	30 lb-in
7	1/4"-20 x 1/2" HEX HEAD SEMS* ASSEMBLY SCREW	**	72 lb-in
8	1/4"-20 BELLEVILLE WASHER NUT	1	72 lb-in
9	1/4"-20 x 3-1/4" SLOTTED ROUND HEAD SCREW	***	20 lb-in

\* SEMS ASSEMBLY SCREWS HAVE A CAPTIVE WASHER ON THE SCREW

\*\* (2) FOR 1Ø, (3) FOR 3Ø

\*\*\* (1) FOR 1Ø, (2) FOR 3Ø

**1-PHASE  
P1-250**

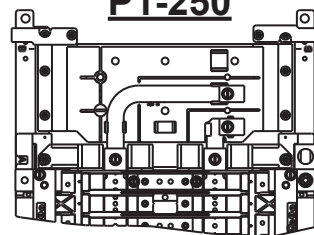

# Installation Instructions

The following instructions are for the installation of a Siemens main/subfeed breaker kit for **225A MAX** QR2, QRH2, HQR2 and HQR2H breakers in Revised P1 Panelboards. The kit may be installed as a main or a subfeed in panels rated 250 amps or less. For panels above 250 amps, it may be installed in subfeed applications **ONLY** (see drawing at the bottom of the page). The parts provided in this kit are for connection to a 1-phase, 2 or 3-wire system in kit **MBKQR1A** or for connection to a 3-phase, 3 or 4-wire system in kit **MBKQR3A**. The breaker is **NOT** included with this kit and must be purchased separately. Be sure to choose the appropriate breaker for the system in use. For systems with no neutrals, disregard the neutral connection.

**(NOTE: Some main breaker kits -- not MBKQR1A or MBKQR3A -- may include this kit AND a breaker. If that is the case, the breaker will be pre-installed onto the barrier and alternate steps on Page 4 should be used.)**



1. Lock off all power supplying this equipment before working on it.
2. Remove the deadfront.
3. To install this kit for main breaker use, remove the main lugs (if installed).
4. Locate the breaker barrier assembly (Item 1) at the MAIN END of the panel. Ensure the straps are properly snapped into the barrier and then align them with the panel bus. Secure the straps to the phase bus with 1/4"-20 SEMS screws (Item 5). Then secure the barrier to the base rails with #10-24 thread-forming screws (Item 6). Do not tighten at this time.
5. Assemble the breaker (purchased separately) onto the breaker barrier assembly using 1/4"-20 x 3-1/4" slotted round head screws (Item 9). Torque these two specific screws to 20 lbs-in MAX. Then use 1/4"-20 x 1/2" SEMS screws (Item 7) to secure the breaker to the connectors.
6. On 1-phase, 3-wire & 3-phase, 4-wire systems the neutral lug assembly (Item 4) is required. The neutral lug assembly comes in the kit ready to assemble at any open corner. Position it below the neutral cross bus, insert the exposed stud through the appropriate hole and secure with a 1/4"-20 belleville washer nut (Item 8).
7. Torque all connections to the values specified on the Hardware Tightening Torque label affixed to the rear of the deadfront.
8. Attach the main cables to the breaker and neutral terminal and torque connections to values specified on the device. If no values are listed on the device, refer to the Hardware Tightening Torque label affixed to the rear of the deadfront.
9. Remove the blank filler or escutcheon installed on any deadfront opening in the area that will cover this kit. Install the breaker escutcheon (Item 2) provided with this kit into the front of the deadfront by first inserting the static clips on one end of opening and then swinging the other end into position until it firmly "clicks" into place.
10. For main breaker applications, apply the "MAIN" label (Item 3) to the breaker escutcheon as shown. (Note: Service entrance panels require a service disconnect label from the bonding kit -- sold separately -- instead of the "MAIN" label.)
11. **Before energizing the panel**, ensure that ALL connections have been properly torqued, that the deadfront is installed and that all fillers are in place.

**Installation as a 225A MAX main breaker\*:**

\* For 250A panels ONLY

**(NOTE: If the breaker kit arrives with the breaker pre-installed onto the barrier assembly, use alternate Steps 4a and 5a on Page 4 instead of Steps 4 & 5 below.)**

**Installation as a 225A MAX subfeed breaker\*\*:**

12. Follow Steps 1 through 10, except that the kit must be installed at the FEED-THRU OR SUBFEED END of the panel and any pre-existing assembly at that location must be removed prior to installation of this kit. In addition, do NOT install the "MAIN" label. Finish with Step 11.

\*\* For panels with feed-thru or subfeed space ONLY

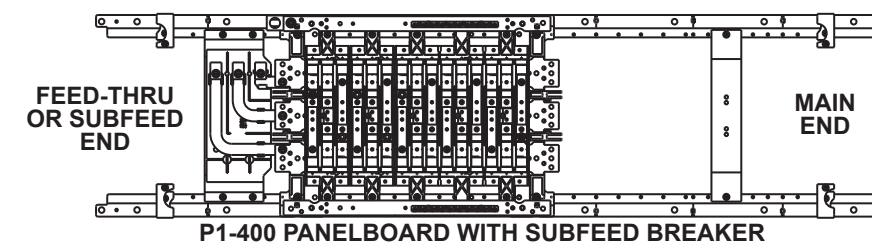

P1-400 PANELBOARD WITH SUBFEED BREAKER