

Axcent
LED wall mount luminaire

Lumark



EATON

Powering Business Worldwide

Sleek architectural design with superior performance.

The all-in-one solution for outdoor lighting.

The Axcent LED wall mount luminaire delivers value through superior performance, reliability, mounting versatility, and multiple control solutions all in a sleek, architectural style. This innovative, patent-pending LED luminaire provides high performing, energy-efficient illumination resulting in up to 95% energy and maintenance savings. The die-cast aluminum construction along with stainless steel hardware, gasketed housing, and sealed optical compartment make the Axcent impervious to contaminants. The Axcent luminaire is ideal for pathway illumination, building entrances, vehicle ramps, schools, tunnels, stairways, loading docks and floodlighting applications.

The Axcent deploys great efficiencies and uniformity in both full cutoff and refractive lens designs. Versatile mounting options available for wall, inverted, floodlight (slipfitter, knuckle and trunnion), and pole-mount luminaire applications. The Axcent also provides expansive controllability and connectivity to meet codes with maximum energy savings. Offering lumen packages ranging from 1,806 to 17,346 lumens, the Axcent luminaire is the ideal solution for replacing legacy HID solutions ranging from 70 up to 450 watts.

The innovative Axcent luminaire delivers a broad selection of solutions with superior illumination, reliability, ease of installation, controllability, and application versatility. Eaton's Axcent is an excellent choice providing value and performance for all outdoor lighting applications.





Combining versatility and value.

Superior illumination

The Axcent wall mount luminaire combines the latest premium LED technology of high efficiency, discrete LEDs for enhanced uniformity and high-precision engineered optics in a low-profile, cost-effective design. The Axcent is offered in full cutoff and refractive lens models to accommodate different light distribution requirements. Full cutoff models integrate a molded lens assembly for Dark Sky compliance. Refractive lens models incorporate a molded lens assembly designed for maximum forward throw. The Axcent is available in cool 5000K, neutral 4000K, and warm 3000K color temperatures. With lumen packages ranging from 1,806 to 17,346 lumens, the Axcent is the ideal solution for any outdoor lighting application.

Reliability and long life

The innovative housing design enables all features to be fully integrated into a single housing to ensure a fully sealed unit for protection against outdoor environments. The rugged, die-cast aluminum housing is IP66 rated, UL wet location listed, and 3G vibration rated for exceptional durability and long-term reliability in -40°C to 40°C applications. With lumen maintenance of greater than 94%, the Axcent is virtually maintenance free for over 32 years.

Ease of installation

The Axcent is built with multiple contractor-friendly installation features. The luminaire comes with a steel wedge mounting plate with integrated bubble level that adapts directly to the wall or j-box. The pre-installed wire hook allows the luminaire to hang while making electrical connections. No need to open the factory-sealed and vacuum tested housing, simply "Hook-N-Lock" to attach the luminaire to the mounting plate and secure with the two set screws. The simple "Hook-N-Lock" mechanism on the back of the Axcent allows for installation of the luminaire without requiring any additional caulking or silicone to seal the luminaire.

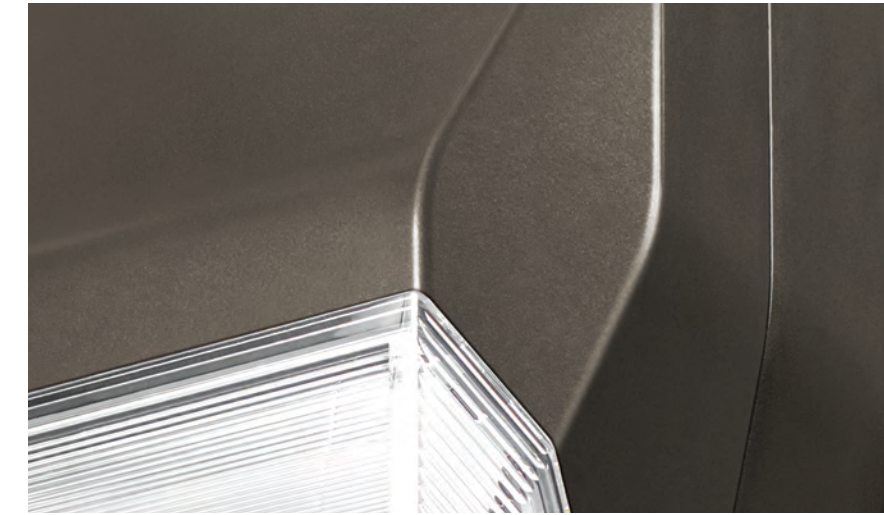
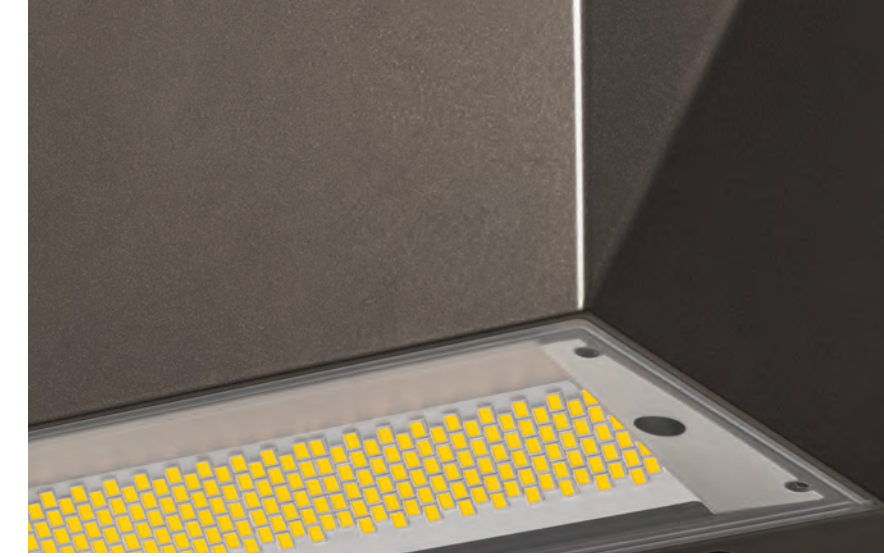

Fully controllable to maximize energy savings.

Designed to be a simple solution to solve complex problems.

The Axcent seamlessly integrates the luminaire's standard 0-10V dimming driver with optional integrated and advanced controls to provide additional energy savings by reducing unnecessary light levels and power consumption. Many of these options comply with California Title 24 and ASHRAE energy code requirements.



LumaWatt Pro
(Wireless Connected Lighting System powered by Enlighted)
LumaWatt Pro transforms a lighting system into an IoT infrastructure with limitless potential to keep up with the growing service demands of people, property and resources. LumaWatt Pro is a distributed network of smart LED lighting fixtures with integrated sensing and beacon technology that enables the ability to control the lighting through remote control, zoning, and scheduling for advanced energy management and data analytics.

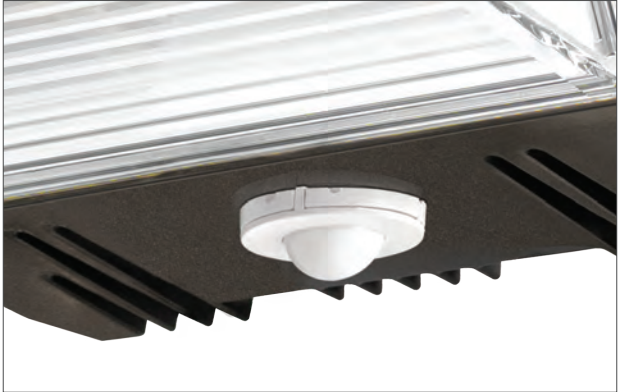

Integrated sensor
Capture the benefits of traditional lighting controls. The integrated sensor delivers additional energy savings by ensuring lighting is turned off or dimmed when a space is unoccupied. The integrated photocell adds an additional level of "dusk-to-dawn" control through daylight sensing and harvesting.



Button photocontrol
The optional button type photocontrol provides a simple solution to enable "dusk-to-dawn" lighting by sensing light levels.
After hours dim
This feature allows photocontrol-enabled luminaires to achieve additional energy savings by dimming during scheduled portions of the night. The dimming profile will automatically take effect after a "dusk-to-dawn" period has been calculated from the photocontrol input.





Axcent Small

Performance summary

Lumens: 1,806 - 6,699
Wattage: 14W / 21W / 27W / 44W / 52W
Efficacy: Up to 142 lm/W
CCT/CRI: 4000K / 70 (Standard), 5000K / 70, 3000K / 80

Electrical data (Electronic LED driver)

Power Factor: >0.9
Total Harmonic Distortion: <20%
Minimum Temperature: -40°C
Ambient Temperature Rating: 40°C (50°C optional)
Operation: 120-277V 50/60Hz, 347V 60Hz, 480V 60Hz
Controls: 0-10V dimming (Standard), Button photocontrol, Integrated sensor, LumaWatt Pro
Surge Protection: 6kV inherent in driver (10kV/10kA surge protection optional)

Additional information

Warranty: 5 year
Vibration Tested: 3G
UL/cUL Listed: Wet location
IP66 Rated: Yes
LM79/LM80: L90 at 72,000 hours (25°C)
RoHS: Compliant
Approximate Net Weight: 5 - 10 lbs. (2.36 - 4.40 kgs.)

Energy and maintenance savings

Annual savings: Up to 95%

Options and accessories

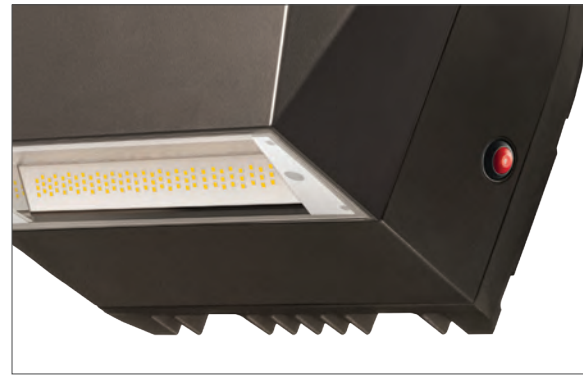

Emergency egress

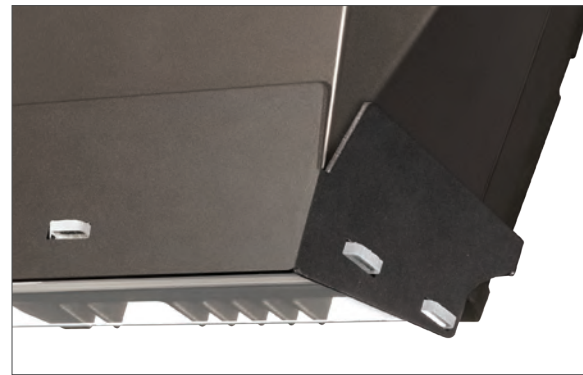

Visor and vandal shield



Wire guard



Full cutoff



Refractive lens



Slipfitter mount



Knuckle mount



Trunnion mount

Axcent Large

Performance summary

Lumens: 6,619 - 17,346
Wattage: 56W / 72W / 102W / 123W
Efficacy: Up to 144 lm/W
CCT/CRI: 4000K / 70 (Standard), 5000K / 70, 3000K / 80

Electrical data (Electronic LED driver)

Power Factor: >0.9
Total Harmonic Distortion: <20%
Minimum Temperature: -40°C
Ambient Temperature Rating: 40°C (50°C optional)
Operation: 120-277V 50/60Hz, 347V 60Hz, 480V 60Hz
Controls: 0-10V dimming (Standard), Button photocontrol, Integrated sensor, LumaWatt Pro, After hours dimming
Surge Protection: 6kV inherent in driver (10kV/10kA surge protection optional)

Additional information

Warranty: 5 year
Vibration Tested: 3G
UL/cUL Listed: Wet location
IP66 Rated: Yes
LM79/LM80: L94 at 72,000 hours (25°C)
RoHS: Compliant
EPA: 1.1 (Pole mount)
Approximate Net Weight: 12 - 21 lbs. (5.4 - 9.5 kgs.)

Energy and maintenance savings

Annual savings: Up to 88%

Options and accessories

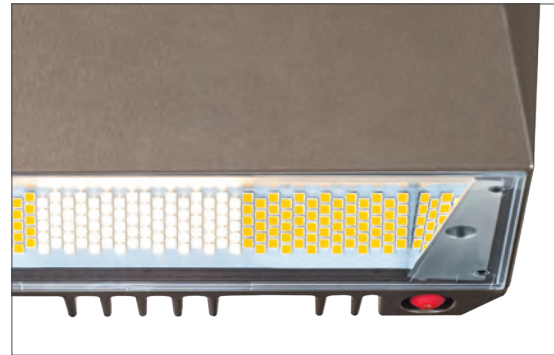

Emergency egress



Visor and vandal shield

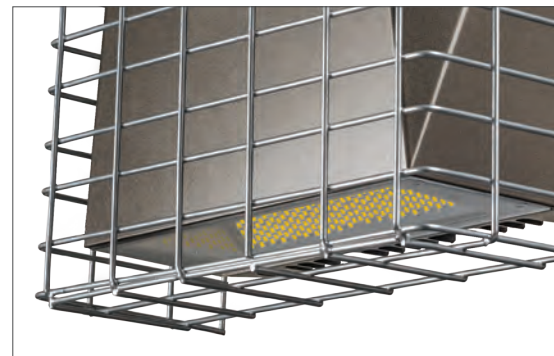

Wire guard

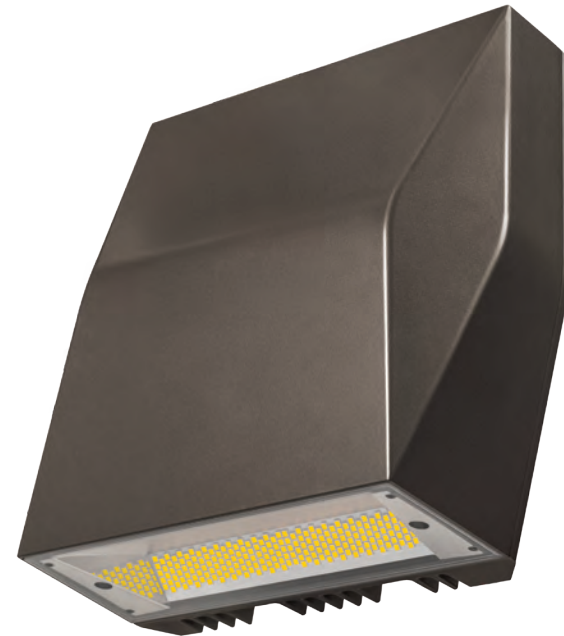

Full cutoff



Refractive lens



Slipfitter mount



Trunnion mount



Pole mount

Dimensions

Axcent Small

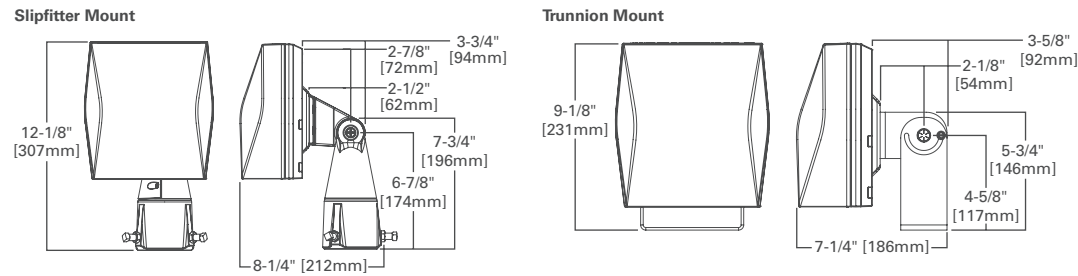
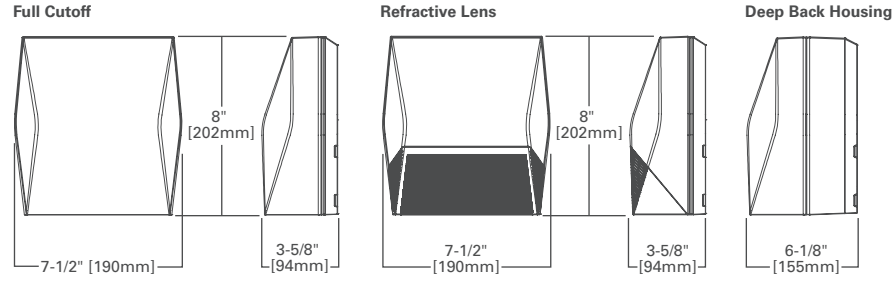

Axcent Large

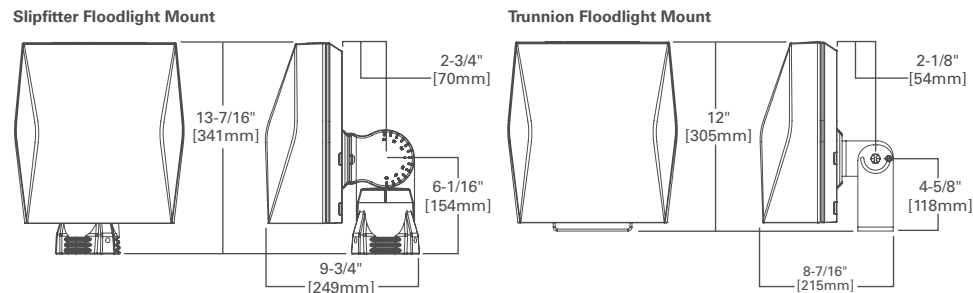
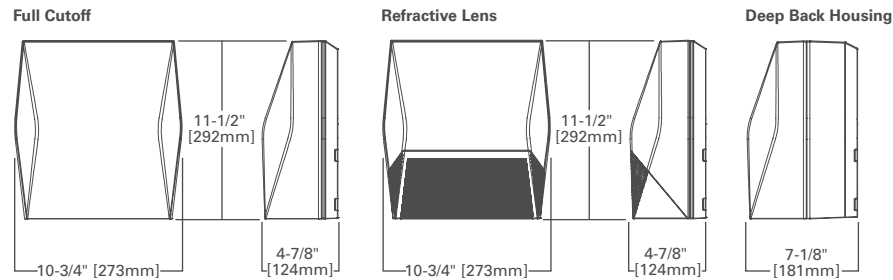

Wall Mount Plate Detail (Small)

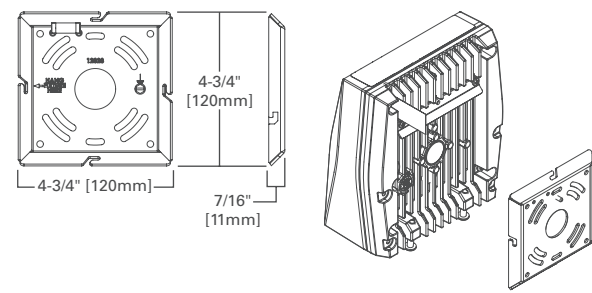

Knuckle Mount (Small)

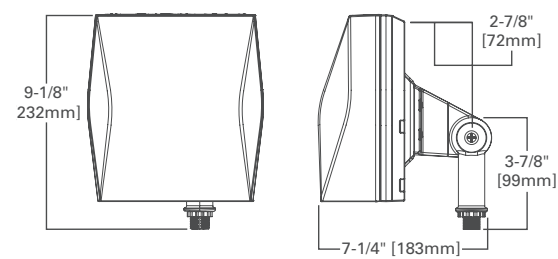

Wall Mount Plate Detail (Large)

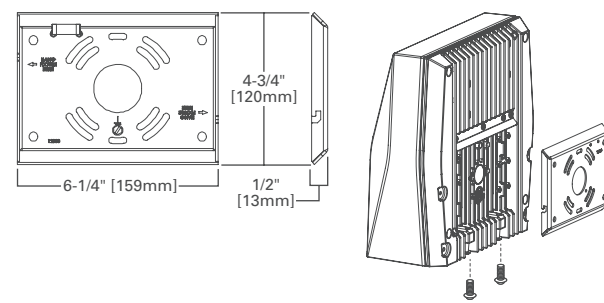

Pole Mount Arm (Large)

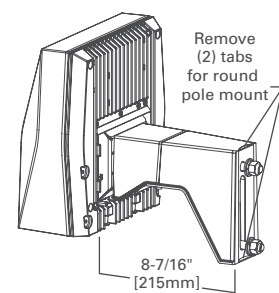

Drill Pattern

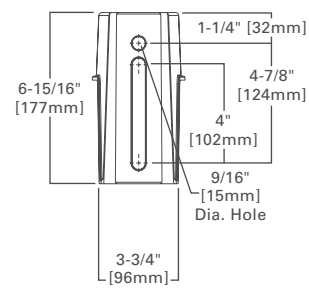

Finish selection

Five-stage super TGIC paint resists extreme weather conditions, while providing optimal color and gloss retention.

Eaton utilizes premium ultra-weatherable TGIC based polyester powder coatings specifically formulated to withstand extended outdoor exposure while providing decorative appeal. Finish is compliant to 3,000 hour salt spray standard (per ASTM B117). RAL and custom color matches available.

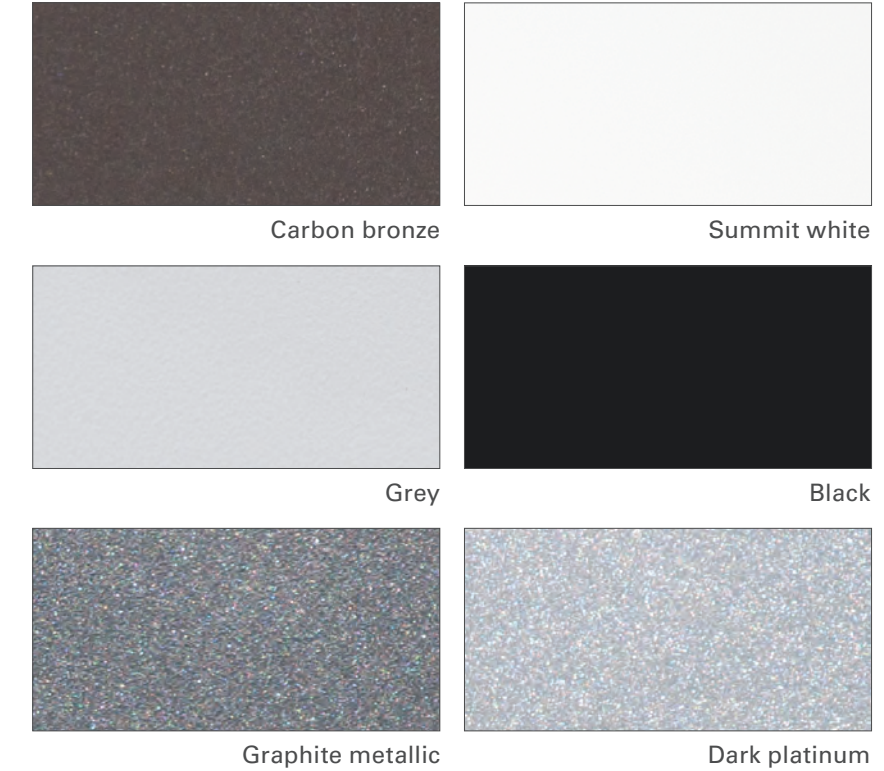

NOTE: Carbon bronze is standard on stock configurations. Colors and textures above have been matched as close as possible. Paper and ink limitations, as well as the influence of heat and light, account for differences from actual coatings.



Lighting Product Lines

Ametrix
AtLite
Corelite
Ephesus
Fail-Safe
Halo
Halo Commercial
Halo Outdoor
Invue
io
Iris
Lumark
Lumière
McGraw-Edison
Metalux
MWS
Neo-Ray
Portfolio
RSA
Shaper
Streetworks
Sure-Lites

Controls Product Lines

Fifth Light Technology
Greengate
iLight (International Only)
iLumin
Zero 88

Connected Lighting Systems

Distributed Low-Voltage Power
HALO Home
iLumin Plus
LumaWatt Pro
WaveLinx



Lumark | Axcent
LED wall mount luminaire