



► Model 141ST

Electraflash® Strobe Light

Federal Signal's Electraflash® 141ST is a strobe light designed for a variety of industrial uses. This compact warning light is less than six inches tall and six inches in diameter.

Model 141ST includes a removable strobe mechanism. The 12VDC and 24VDC units have three holes for flat surface mounting. The 120VAC and 240VAC versions come ready to mount on a 1/2-inch NPT pipe. Optional wall mounting brackets (Model LWMB2) or corner mounting brackets (Model LCMB2) are available for the 120VAC and 240VAC units.

Federal Signal's Electraflash strobe lights are designed for both indoor and outdoor industrial environments. The unit's convenient size and intense light output make it ideal for use on maintenance vehicles, fork lifts, and other material handling equipment, effectively alerting hazardous conditions or dangerous areas.

FEATURES

- Available in 12VDC, 24VDC, 120VAC and 240VAC
- Five lens colors: Amber, Blue, Clear, Green and Red
- 4,000 hour strobe tube
- Surface mount or integrated 1/2-inch NPT pipe mount models
- Indoor/outdoor use
- Conformal coated PCB
- Type 3R enclosure
- CSA Certified
- UL and cUL Listed

MODEL	VOLTAGE	OPERATING CURRENT	FLASH RATE/ MINUTE	LIGHT OUTPUT PEAK ¹	MOUNT
141ST-012 *	12VDC	0.18 amps	80	100,000 cd	Surface
141ST-024 *	24VDC	0.08 amps	80	100,000 cd	Surface
141ST-120 *	120VAC 50/60HZ	0.06 amps	80	100,000 cd	1/2" NPT Pipe
141ST-240 *	240VAC 50/60HZ	0.03 amps	80	100,000 cd	1/2" NPT Pipe

* Indicates color: (A) Amber, (B) Blue, (C) Clear, (G) Green or (R) Red

¹ Peak candela is the maximum light intensity generated by a flashing light during its light pulse

Electraflash® Strobe Light (141ST)

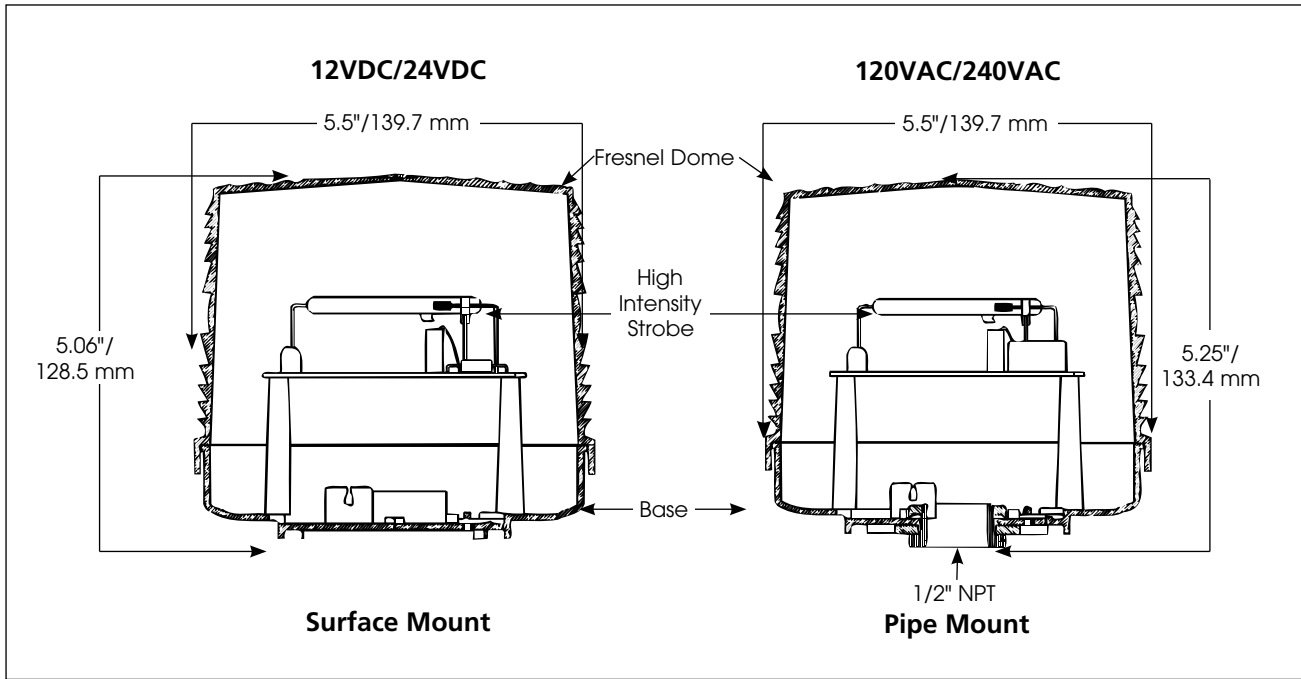

SPECIFICATIONS

Lamp Life:		4,000 Hours
Light Source:		Strobe tube
Operating Temperature:	-31°F to 150°F	-35°C to 66°C
Net Weight:		
DC Models	0.8 lbs	0.36 kg
AC Models	0.9 lbs	0.41 kg
Shipping Weight:		
DC Models	1.3 lbs	0.5 kg
AC Models	1.4 lbs	0.5 kg
Height:		
DC Models	5.06"	128.5 mm
AC Models	5.25"	133.4 mm
Diameter:		
DC Models	5.5"	139.7 mm
AC Models	5.5"	139.7 mm

REPLACEMENT PARTS

Description	Part Number
Lens, Amber	K8263079A
Lens, Blue	K8263079A-01
Lens, Clear	K8263079A-04
Lens, Green	K8263079A-03
Lens, Red	K8263079A-02
Strobe Tube	K149128A

OPTIONAL ACCESSORIES

(120VAC/240VAC pipe mount models only)

Description	Part Number
Corner Bracket	LCMB2*
Wall Bracket	LWMB2*

* Type 3R rated

Mounting Brackets shown on pages 136-137

HOW TO ORDER

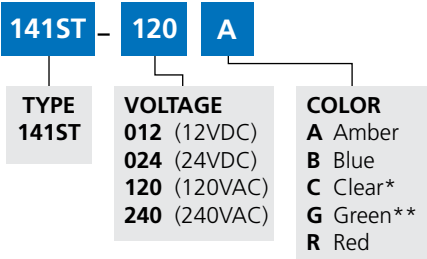

* Clear option only available in 240VAC

** Green option not available in 12VDC