



Main

Product or component type	Circuit breaker
Range of product	PowerPact H
Trip Unit Type	Thermal-magnetic
Breaking capacity code	D

Complementary

Line Rated Current	150 A
Number of Poles	3P
Interrupt Rating	25 KA 240 V AC 18 KA 480 V AC 14 KA 600 V AC 20 kA 250 V DC
[Ue] rated operational voltage	250 V DC 600 V AC
Continuous current rating	80 %
Mounting mode	Unit mount
Electrical connection	Lugs load Lugs line
Wire Gauge	AWG 14...AWG 3/0 aluminium/copper
Magnetic hold current	900 A
Magnetic tripping current	1700 A
Maximum Height	6.4 in (162.56 mm)
Maximum Width	4.12 in (104.65 mm)
Maximum Depth	4.36 in (110.74 mm)
Tightening torque	44.25 lbf.in (5 N.m) 0.00...0.15 in ² (2.5...95 mm ²) AWG 14...AWG 3/0

Environment

Product certifications	CSA IEC CE UL Listed
Ambient air temperature for operation	104 °F (40 °C)

Ordering and shipping details

Category	01110 - HD,JD UNIT MT BREAKER/SWITCH
Discount Schedule	DE2
GTIN	00785901623212
Nbr. of units in pkg.	1
Package weight(Lbs)	4.2 lb(US) (1.91 kg)
Returnability	Yes
Country of origin	MX

Packing Units

Unit Type of Package 1	PCE
Package 1 Height	5.70 in (14.478 cm)
Package 1 width	7.50 in (19.05 cm)
Package 1 Length	8.60 in (21.844 cm)
Unit Type of Package 2	PAL
Number of Units in Package 2	140
Package 2 Weight	611.00 lb(US) (277.145 kg)
Package 2 Height	42.00 in (106.68 cm)
Package 2 width	40.00 in (101.6 cm)
Package 2 Length	48.00 in (121.92 cm)

Offer Sustainability

Sustainable offer status	Green Premium product
REACH Regulation	REACH Declaration
EU RoHS Directive	Compliant EU RoHS Declaration
Mercury free	Yes
RoHS exemption information	Yes
China RoHS Regulation	China RoHS Declaration
Environmental Disclosure	Product Environmental Profile
PVC free	Yes

Contractual warranty

Warranty	18 months
----------	-----------

Approximate Dimensions

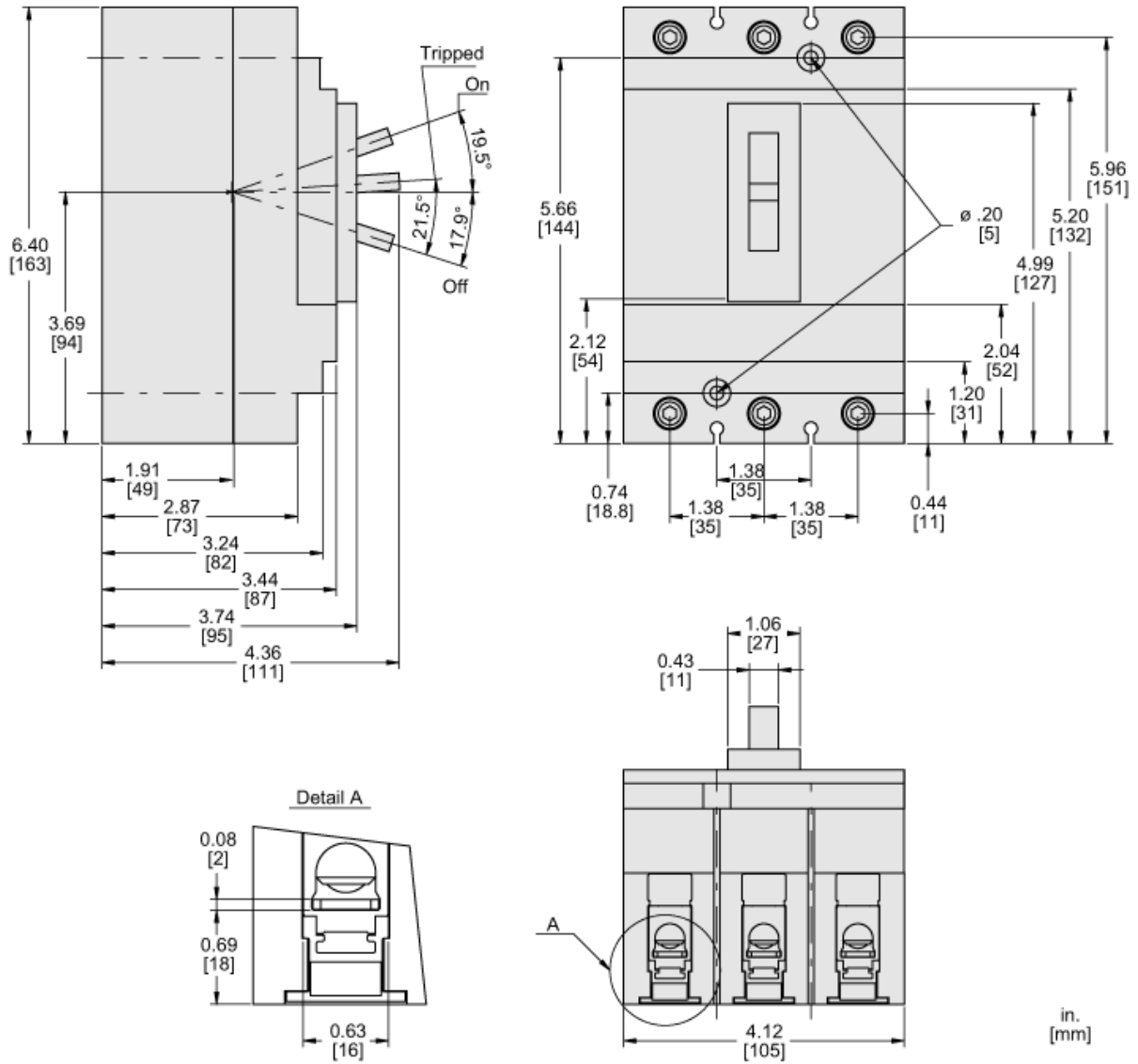

Tripping Curve

