



# Opaque Cover



**CONFIGURATION**  
Hinged, padlock latch



## HPL Construction

<b>Material</b>	SolarGuard® – Hot compression molded fiberglass reinforced polyester (thermoset)
<b>Gasket</b>	Poured polyurethane seamless gasket provides watertight, dust-tight environmental seal.
<b>Stainless Steel Hardware</b>	300 Series stainless used on all external hardware.
<b>Molded in Mounting Flange</b>	Molded in flange for ease of mounting.
<b>Mounting Bosses</b>	Panel mounting capability for fixed rear panel.
<b>Metal Inserts</b>	Back panel utilizes threaded brass inserts accepting 10-32 screws.
<b>Soft Edge Design</b>	Rounded edges, minimal protrusions or exposed pocket areas for assembly of dust and debris.
<b>Color</b>	Available standard glacier grey (PMS 428C) or White*.

## HPL Modifications

<b>Custom Colors</b>	pg. 21-22
<b>Silk Screening</b>	pg. 21-22
<b>EMI/RFI Shielding</b>	pg. 21-22
<b>Custom Window</b>	pg. 21-22
<b>Custom Cutouts/Holes</b>	pg. 21-22

## HPL Industry Standards

<b>NEMA 250, UL Listed UL50, UL50e, UL508A</b>	File E64358 Type 1, 3R, 4X, 6P*, 12
<b>CSA Std C22.2</b>	File LR069014; Type 1, 3R, 4X, 6P*, 12
<b>IEC 60529</b>	File E362920 IP66; IP 6X for 3PT
<b>UL1741</b>	File E333478; W, HW, HPL, FHW
<b>Plenum Space (UL2043) Compliant</b>	Yes
<b>Temperature Range</b>	(-76°F to +274°F) (-60°C to +134°C)
<b>Flammability Rating</b>	UL94-5V
<b>Impact Rating</b>	IK10
<b>Self Extinguishing</b>	Non-halogenated, non-flame propagating
<b>Chemical Resistance</b>	Full chemical resistance charts listed in appendix
<b>NFPA No. 101 Flame Spread</b>	Class A (1)
<b>Outdoor Exposure UL746C</b>	(f1) Rated

## HPL Accessories

<b>PANELS</b>	<b>Aluminum</b>	BP_AL	pg. 174-175
	<b>Fiberglass</b>	BP_FG	pg. 174-175
	<b>Stainless Steel</b>	BP_SS	pg. 174-175
	<b>Carbon Steel</b>	BP_CS	pg. 174-175
<b>ACCESSORIES</b>	<b>Dead Front Panels</b>		pg. 180-181
	<b>Drain &amp; Breather Vents</b>		pg. 185
	<b>Hole Plugs</b>		pg. 187
	<b>Assorted Hubs and Cord Grips</b>		pg. 188-189
	<b>All Other Accessories</b>		pg. 184-194

\* Consult Factory on available sizes.

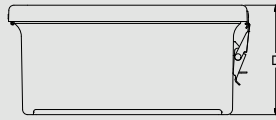
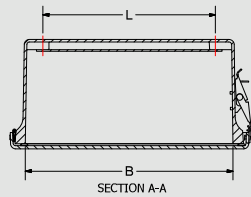

- NOTES:
1. CATALOG DRAWING IS FOR REFERENCE ONLY
  2. SEE ACTUAL PART DRAWING FOR SPECIFIC DESIGN
  3. "J" DIMENSION IS WITH 0.080" THICK BACK PANEL INSTALLED
  4. BACK PANEL IS SOLD SEPARATELY

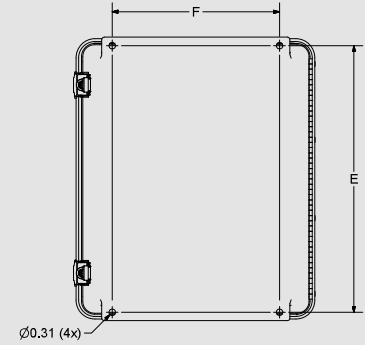
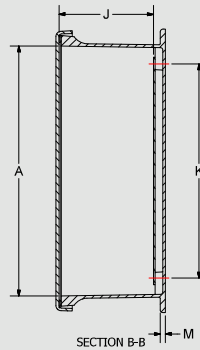
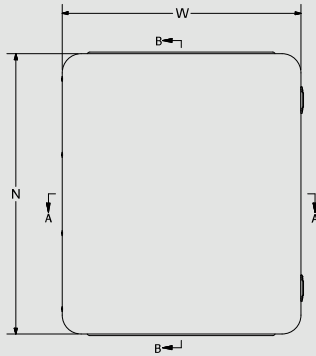
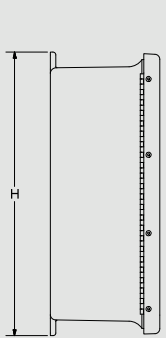

SCREW SIZES & TORQUE VALUES

PRODUCT SIZES	BACK PANEL SCREW SIZE	BACK PANEL RECOMMENDED TORQUE	COVER SCREW SIZE	COVER SCREW RECOMMENDED TORQUE	RECOMMENDED MOUNTING FLANGE TORQUE
J604 up to J2016	#10-32 x 3/8	16 - 20 in-lbs	#10-24 x 5/8	20 - 24 in-lbs	45 in-lbs max
J2020 up to J2424	1/4-20 x 1/2	20 - 24 in-lbs	N/A	N/A	80 in-lbs max

J Series – Opaque Cover

CATALOG NUMBER	OVERALL H X W X D	INSIDE A X B X C	MOUNTING E X F	J	K	L	M	N	HOLE DIAMETER	SHIP WEIGHT	PANEL NUMBER
J604HPL*** J604HW*** J604W J604HLL	7.47 x 5.45 x 4.70 (190 x 138 x 119)	5.84 x 3.85 x 4.45 (148 x 98 x 113)	6.75 x 2.00 (171 x 51)	3.97 (101)	4.25 (108)	2.25 (57)	0.25 (6)	7.39 (188)	0.31 (8)	2.40 lbs.	BP64**
J606HPL*** J606HW*** J606W J606HLL	7.50 x 7.53 x 4.82 (191 x 191 x 122)	5.72 x 5.72 x 4.45 (145 x 145 x 113)	6.75 x 4.00 (171 x 101)	3.97 (101)	4.25 (108)	4.25 (108)	0.25 (6)	7.53 (191)	0.31 (8)	2.80 lbs.	BP66**
J806HPL*** J806HW*** J806W J806HLL J806FHW	9.63 x 7.52 x 4.70 (245 x 191 x 119)	7.73 x 5.74 x 4.45 (196 x 146 x 113)	8.88 x 4.00 (225 x 101)	3.92 (100)	6.25 (159)	4.25 (108)	0.25 (6)	9.5 (242)	0.31 (8)	3.50 lbs.	BP86**
J808HPL*** J808HW*** J808W J808HLL J808FHW	9.56 x 9.38 x 4.87 (243 x 238 x 124)	7.73 x 7.73 x 4.62 (196 x 196 x 117)	8.75 x 6.00 (222 x 152)	3.98 (101)	6.25 (159)	6.25 (159)	0.25 (6)	9.38 (238)	0.31 (8)	3.80 lbs.	BP88**

All measures are in inches, items in parentheses are in millimeters.



\*Crowned cover - center of cover raised 3/4"



\*\*Panel sold separately



\*\*\*Available in white by placing WH prior to part number. Ex: WH-J604HW



## J Series – Opaque Cover

CATALOG NUMBER	OVERALL H X W X D	INSIDE A X B X C	MOUNTING EX F	J	K	L	M	N	HOLE DIA.	SHIP WEIGHT	PANEL NUMBER
J1008HPL*** J1008HW*** J1008W J1008HLL J1008FHW	11.63 x 9.41 x 4.22 (295 x 239 x 107)	9.73 x 7.73 x 3.98 (247 x 196 x 101)	10.75 x 6.00 (273 x 152)	3.44 (87)	8.25 (210)	6.25 (159)	0.25 (6)	11.35 (288)	0.31 (8)	4.60 lbs.	BP108**
J1008HWA* J1008WA* J1008HALL*	11.63 x 9.37 x 5.05 (295 x 238 x 129)	9.73 x 7.73 x 4.83 (247 x 196 x 123)	10.75 x 6.00 (273 x 152)	4.38 (111)	8.25 (210)	6.25 (159)	0.25 (6)	11.38 (289)	0.31 (8)	4.70 lbs.	BP108**
J100806HPL*** J100806HW*** J100806W J100806HLL J100806FHW	11.97 x 9.42 x 6.61 (304 x 239 x 165)	9.74 x 7.74 x 6.25 (248 x 197 x 159)	10.94 - 10.75 x 6.00 (278 - 273 x 152)	5.67 (141)	8.25 (210)	6.25 (159)	0.25 (6)	11.42 (290)	0.31 (8)	5.20 lbs.	BP108**
J1210HPL*** J1210HW*** J1210W J1210HLL J1210FHW	13.56 x 11.43 x 5.22 (344 x 291 x 133)	11.79 x 9.80 x 4.94 (299 x 249 x 125)	12.75 x 8.00 (324 x 203)	4.50 (114)	10.25 (260)	8.25 (210)	0.25 (6)	13.41 (341)	0.31 (8)	6.60 lbs.	BP1210**
J1212HPL*** J1212HW*** J1212W J1212HLL J1212FHW	13.56 x 13.38 x 6.34 (344 x 340 x 161)	11.70 x 11.70 x 6.10 (297 x 297 x 155)	12.75 x 10.00 (324 x 254)	5.51 (140)	10.25 (260)	10.25 (260)	0.25 (6)	13.38 (340)	0.31 (8)	8.40 lbs.	BP1212**
J1407HPL*** J1407HW*** J1407W J1407HLL J1407FHW	15.87 x 8.75 x 6.81 (403 x 222 x 173)	14.00 x 7.00 x 6.56 (356 x 178 x 167)	15.00 x 5.00 (381 x 127)	6.11 (155)	12.25 (311)	5.25 (133)	0.25 (6)	15.75 (400)	0.31 (8)	6.10 lbs.	BP1407**
J1412HPL*** J1412HW*** J1412W J1412HLL J1412FHW	15.50 x 13.48 x 6.20 (394 x 342 x 158)	13.52 x 11.52 x 5.94 (343 x 293 x 151)	14.63 x 10.00 (372 x 254)	5.36 (137)	12.25 (311)	10.25 (260)	0.25 (6)	15.48 (393)	0.31 (8)	9.90 lbs.	BP1412**
J1614HPL*** J1614HW*** J1614W J1614HLL J1614FHW	17.53 x 15.46 x 6.21 (445 x 393 x 157)	15.60 x 13.56 x 5.94 (396 x 344 x 151)	16.75 x 12.00 (425 x 305)	5.35 (136)	14.25 (362)	12.25 (311)	0.25 (6)	17.46 (444)	0.31 (8)	12.20 lbs.	BP1614**
J1816HPL*** J1816HW*** J1816W J1816HLL J1816FHW	19.63 x 17.63 x 8.81 (499 x 447 x 224)	17.69 x 15.69 x 8.45 (449 x 399 x 215)	18.88 x 12.00 (479 x 305)	7.98 (203)	16.25 (413)	14.25 (362)	0.25 (6)	19.61 (498)	0.31 (8)	20.00 lbs.	BP1816**
J2016HPL*** J2016HW*** J2016W J2016HLL J2016FHW	22.00 x 17.68 x 8.81 (559 x 449 x 224)	19.72 x 15.72 x 8.45 (501 x 399 x 215)	21.25 x 10.00 (540 x 254)	7.98 (203)	18.25 (464)	14.25 (362)	0.25 (6)	21.68 (551)	0.31 (8)	22.50 lbs.	BPJ2016**
J2020HPL J20203PT	23.50 x 22.12 x 11.70 (597 x 562 x 297)	19.88 x 19.88 x 11.33 (505 x 505 x 288)	21.88 x 18.30 (556 x 465)	10.49 (266)	15.25 (387)	15.25 (387)	0.50 (13)	22.1 (561)	0.44 x 0.38 (11 x 10)	30 lbs.	BPJ2020**
J2420HPL J24203PT	27.50 x 22.12 x 11.70 (699 x 562 x 297)	23.88 x 19.88 x 11.33 (607 x 505 x 288)	25.88 x 18.30 (657 x 465)	10.49 (266)	19.25 (489)	15.25 (387)	0.50 (13)	26.1 (663)	0.44 x 0.38 (11 x 10)	36 lbs.	BPJ2420**
J2424HPL J24243PT	27.50 x 26.12 x 11.70 (699 x 663 x 297)	23.88 x 23.88 x 11.33 (607 x 607 x 288)	25.88 x 22.00 (657 x 559)	10.49 (266)	19.25 (489)	19.25 (489)	0.50 (13)	26.1 (663)	0.44 x 0.38 (11 x 10)	42 lbs.	BPJ2424**

All measures are in inches, items in parentheses are in millimeters.



\*Crowned cover – center of cover raised 3/4"



\*\*Panel sold separately



\*\*\*Available in white by placing WH prior to part number. Ex: WH-J604HW