

SCREW: 130072	MATERIAL: SEE NOTES 1 & 2	REV: K		
CAT. NO.: IPC-350-350 & IPC-350-350-B	PLATING: NONE	DRAWN BY: JG	SCALE: 1:2	800-776-9775 www.ilsco.com
INFORMATION SHEET:	MARKING: NONE	DATE: 2/5/2008	SIZE: A	DWG. NO. K0429
				SHEET: 1 OF 1

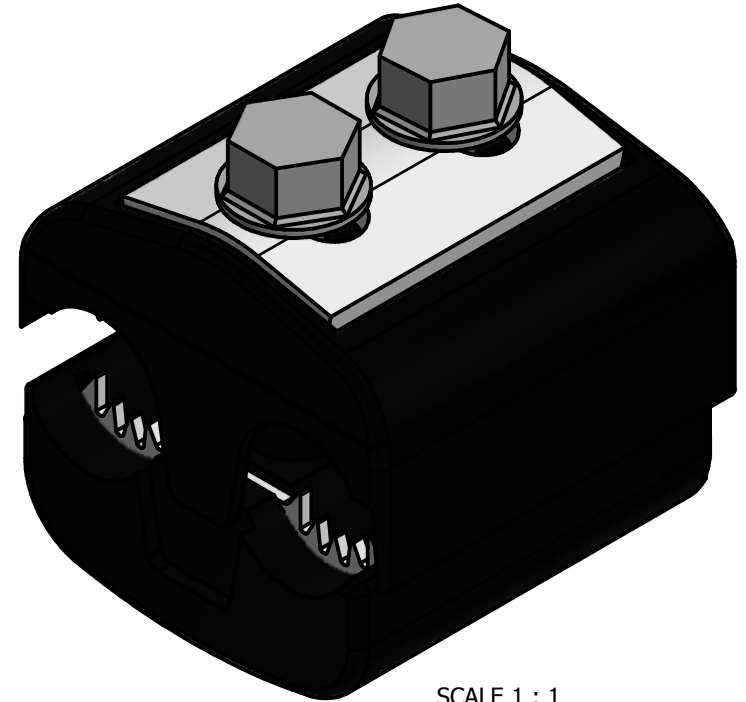
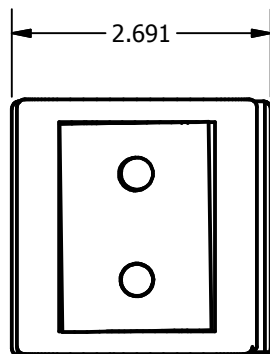
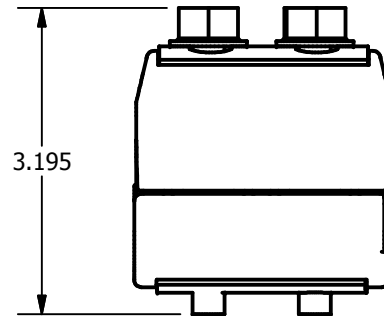
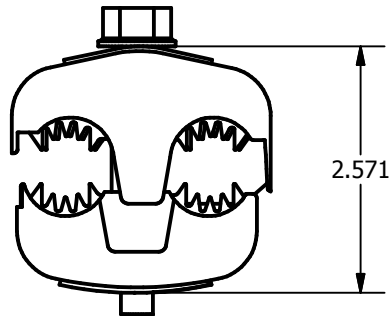
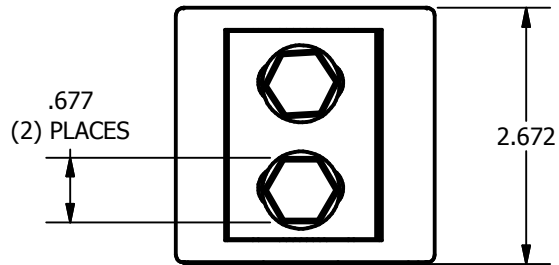

- NOTES:
1. NYLON BODY
 2. TIN PLATED BOPPER TEETH
 3. WIRE RANGE: MAIN - 250kcmil - 1
TAP - 4/0 - 6