

TeSys SK, K Relays - For control of TeSys K contactor coils and other devices

Type of product

Pages

Mini relay - 2 contacts, simultaneous action
TeSys SK, SKE



B7/2

Relays - 4 contacts, simultaneous action
TeSys K



B7/4

Auxiliary contact blocks, accessories



B7/6

TeSys D Relays - For control of TeSys D contactor coils and other devices

Relays and auxiliary contact blocks
5 contacts, simultaneous action
TeSys D



B7/8

Accessories



B7/10

Control
relays

Technical Data for Designers

B7/13

TeSys

TeSys SK, SKE Mini-control relays

Product references

PB121522.tif



CA2SK11●●

Mini-control relays

- Width of mini-control relays 27 mm.
- Mounting on 35 mm rail.
- Connection by connectors.

Control circuit supply	Auxiliary contacts		Basic reference, to be completed by adding the voltage code ⁽¹⁾
a.c. supply	2	–	CA2SK20●●
	1	1	CA2SK11●●
d.c. supply	2	–	CA3SK20●●
	1	1	CA3SK11●●

PB121523.eps



CA2SKE20●●

Mini-control relay with alternating contacts

This mini-control relay with alternating contacts (see function diagram page B7/17) makes it possible to automatically split the operating time between 2 circuits of a redundant system. By regularly energising the “safety circuits”, this device makes it possible to ensure that they are operating correctly.

- Width of mini-control relay 45 mm.
- Fixing by Ø4 screws.
- Connection by connectors.
- Cannot be fitted with front-mounted auxiliary contact block.
- Cannot be fitted with coil suppressor module.

Control circuit supply	Auxiliary contacts		Basic reference, to be completed by adding the voltage code ⁽¹⁾
a.c. supply	2	–	CA2SKE20●●

⁽¹⁾ Standard control circuit voltages (for other voltages, please consult your Regional Sales Office):

Mini-control relays CA2SK and CA2SKE									
Volts ~ 50/60 Hz	24	48	110	120	220	230	240	380	400
Code	B7	E7	F7	G7	M7	P7	U7	Q7	V7
Mini-control relays CA3SK									
Volts –	12	24	36	48	72				
Code	JD	BD	CD	ED	SD				





Control relays



LA1SK●●

Instantaneous auxiliary contact blocks

Clip-on front mounting

For use on control relays	Maximum number of blocks per contactor	Composition		Reference
CA2SK20	1			LA1SK20
		-		LA1SK02
		1	1	LA1SK11



LA4SK●1●

Suppressor modules

Connection without need for tools by clipping onto right-hand side of contactor

For use on control relays	Type	For voltages	Sold in lots of	Unit reference
CA2SK and CA3SK	Varistor (1)	~ and ≍ 24 V...48 V	10	LA4SKE1E
		~ and ≍ 110 V...250 V	10	LA4SKE1U
	Diode (2)	≍ 24 V...250 V	10	LA4SKC1U

- (1) Protection provided by limiting the transient voltage to $2 U_c$ max.
Maximum reduction of transient voltage peaks.
Slight increase in drop-out time (1.1 to 1.5 times the normal time).
- (2) No overvoltage or oscillating frequency.
Slight increase in drop-out time (1.1 to 1.5 times the normal time).



Control relays for a.c. control circuit

- Mounting on 35 mm rail or Ø4 screw fixing.
- Screws in the open "ready-to-tighten" position.

Control circuit Consumption	Auxiliary contacts	Basic reference, to be completed by adding the voltage code ⁽¹⁾

Screw clamp connections		
4.5 VA	4 –	CA2KN40●●
	3 1	CA2KN31●●
	2 2	CA2KN22●●

Spring terminal connections		
4.5 VA	4 –	CA2KN403●●
	3 1	CA2KN313●●
	2 2	CA2KN223●●

Faston connectors, 1 x 6.35 or 2 x 2.8		
4.5 VA	4 –	CA2KN407●●
	3 1	CA2KN317●●
	2 2	CA2KN227●●

Solder pins for printed circuit boards		
4.5 VA	4 –	CA2KN405●●
	3 1	CA2KN315●●
	2 2	CA2KN225●●

Control relays for d.c. control circuit

- Mounting on 35 mm rail or Ø4 screw fixing.
- Screws in the open "ready-to-tighten" position.

Screw clamp connections		
3 W	4 –	CA3KN40●●
	3 1	CA3KN31●●
	2 2	CA3KN22●●

Spring terminal connections		
3 W	4 –	CA3KN403●●
	3 1	CA3KN313●●
	2 2	CA3KN223●●

Faston connectors, 1 x 6.35 or 2 x 2.8		
3 W	4 –	CA3KN407●●
	3 1	CA3KN317●●
	2 2	CA3KN227●●

Solder pins for printed circuit boards		
3 W	4 –	CA3KN405●●
	3 1	CA3KN315●●
	2 2	CA3KN225●●

⁽¹⁾ Standard control circuit voltages (for other voltages, please consult your Regional Sales Office):
Control relays CA2K (0.8...1.15 Uc) (0.85...1.1 Uc)

Volts ~	12	20	24 ⁽²⁾	36	42	48	110	115	127	220/230	230/240	380/400	400/415	440	500	660/690		
Code	J7	Z7	B7	C7	D7	E7	F7	FE7	FC7	M7	P7	U7	Q7	V7	N7	R7	S7	Y7

Up to and including 240 V, coil with integral suppression device available: add 2 to the code required. Example: **J72**

Control relays CA3K (0.8...1.15 Uc)															
Volts ---	12	20	24 ⁽²⁾	36	48	60	72	100	110	125	200	220	230	240	250
Code	JD	ZD	BD	CD	ED	ND	SD	KD	FD	GD	LD	MD	MPD	MUD	UD

Coil with integral suppression device available: add 3 to the code required. Example: **JD3**.

⁽²⁾ When connecting an electronic sensor or timer in series with the coil of the control relay, select a 20 V coil (~ code Z7, --- code ZD) so as to compensate for the incurred voltage drop.



CA2KN22●●



CA2KN●●5●●



CA3KN●●3●●

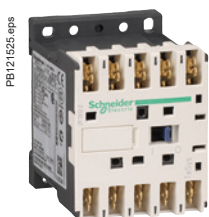

CA3KN●●7●●



Control relays

PB121527 eps



CA4KN40●●●

Low consumption control relays d.c. control circuit

- Mounting on 35 mm rail or Ø4 screw fixing.
- Screws in the open "ready-to-tighten" position.

Control circuit Consumption	Auxiliary contacts	Basic reference, to be completed by adding the voltage code ⁽¹⁾
1.8 W	4 –	CA4KN40●●
	3 1	CA4KN31●●
	2 2	CA4KN22●●

Screw clamp connections

1.8 W	4 –	CA4KN40●●
	3 1	CA4KN31●●
	2 2	CA4KN22●●

Spring terminal connections

1.8 W	4 –	CA4KN403●●
	3 1	CA4KN313●●
	2 2	CA4KN223●●

Faston connectors, 1 x 6.35 or 2 x 2.8

1.8 W	4 –	CA4KN407●●
	3 1	CA4KN317●●
	2 2	CA4KN227●●

Solder pins for printed circuit boards

1.8 W	4 –	CA4KN405●●
	3 1	CA4KN315●●
	2 2	CA4KN225●●

⁽¹⁾ Standard control circuit voltages (for other voltages, please consult your Regional Sales Office):

Control relays CA4K (Wide range coil: 0.7...1.3 Uc)

Volts ~	12	20	24	48	72	110	120
Code	JW3	ZW3	BW3	EW3	SW3	FW3	GW3

Coil with integral suppression device fitted as standard, by bi-directional peak limiting diode.





LA1KN22



LA1KN003



LA1KN007



Control relays

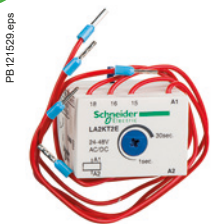

LA2KT2E

Instantaneous auxiliary contact blocks

Clip-on front mounting, 1 per control relay

Connection	Composition		Reference
Screw clamp terminals	2	–	LA1KN20
	–	2	LA1KN02
	1	1	LA1KN11
	4	–	LA1KN40 ⁽¹⁾
	3	1	LA1KN31 ⁽¹⁾
	2	2	LA1KN22 ⁽¹⁾
	1	3	LA1KN13 ⁽¹⁾
	–	4	LA1KN04 ⁽¹⁾
Spring terminals	2	–	LA1KN203
	–	2	LA1KN023
	1	1	LA1KN113
	4	–	LA1KN403 ⁽¹⁾
	3	1	LA1KN313 ⁽¹⁾
	2	2	LA1KN223 ⁽¹⁾
	1	3	LA1KN133 ⁽¹⁾
	–	4	LA1KN043 ⁽¹⁾
Faston connectors 1 x 6.35 or 2 x 2.8	2	–	LA1KN207
	–	2	LA1KN027
	1	1	LA1KN117
	4	–	LA1KN407 ⁽¹⁾
	3	1	LA1KN317 ⁽¹⁾
	2	2	LA1KN227 ⁽¹⁾
	1	3	LA1KN137 ⁽¹⁾
	–	4	LA1KN047 ⁽¹⁾

Electronic time delay contact blocks

- Relay output with common point changeover contact, \sim or \equiv 240 V, 2 A maximum
- Control voltage 0.85... 1.1 Uc
- Maximum switching capacity 250 VA or 150 W
- Operating temperature -10...+ 60 °C
- Reset time: 1.5 s during the time delay period 0.5 s after the time delay period

Clip-on front mounting, 1 per control relay

Voltage	Type	Timing range	Composition	Reference
\sim or \equiv 24...48	On-delay	1...30		LA2KT2E
\sim 110...240	On-delay	1...30		LA2KT2U

Other versions

Electronic timers type RE4.
Please consult your Regional Sales Office.

⁽¹⁾ Block of 4 contacts for use on CA2K and CA3K.

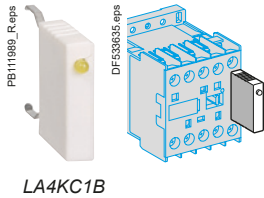

Suppressor modules incorporating LED indicator

Mounting and connection	Type	For voltages	Sold in lots of	Unit reference
Clips onto front of relay with locating device. No tools required.	Varistor ⁽¹⁾	~ and --- 12...24 V	5	LA4KE1B
		~ and --- 32...48 V	5	LA4KE1E
		~ and --- 50...129 V	5	LA4KE1FC
		~ and --- 130...250 V	5	LA4KE1UG
	Diode + Zener diode ⁽²⁾	--- 12...24 V	5	LA4KC1B
		--- 32...48 V	5	LA4KC1E
	RC ⁽³⁾	~ 220...250 V	5	LA4KA1U

Mounting accessories

Description	Application		Sold in lots of	Unit reference
Mounting plates	On 1 □ rail	Clip-on	1	LA9D973
	On 2 □ rails	110/120 mm fixing centres	10	DX1AP25

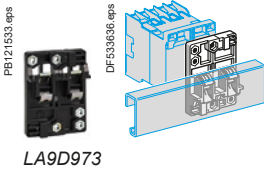

Marking accessories

Description	Application		Sold in lots of	Unit reference
Marker holder	Clip-on fixing on front face	–	100	LA9D90
Clip-in markers	4 maximum per relay	Strips of 10 identical numbers 0 to 9	25	AB1R● ⁽⁴⁾
		Strips of 10 identical capital letters A to Z	25	AB1G● ⁽⁴⁾



- (1) Protection provided by limiting the transient voltage to 2 Uc max. Maximum reduction of transient voltage peaks. Slight increase in drop-out time (1.1 to 1.5 times the normal time).
- (2) No overvoltage or oscillating frequency. Polarised component. Slight increase in drop-out time (1.1 to 1.5 times the normal time).
- (3) Protection by limiting the transient voltage to 3 Uc max. and limitation of the oscillating frequency. Slight increase in drop-out time (1.2 to 2 times the normal time).
- (4) Complete the reference by replacing the dot with the required character.



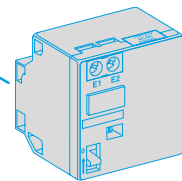
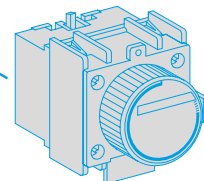
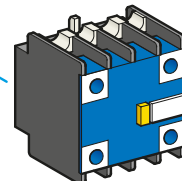
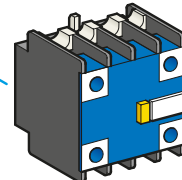
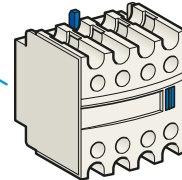
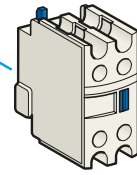
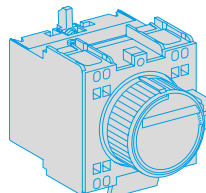
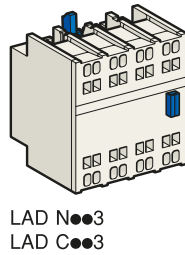
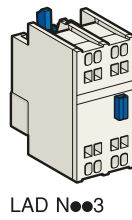
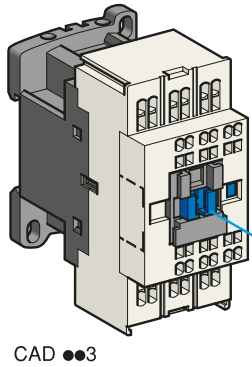
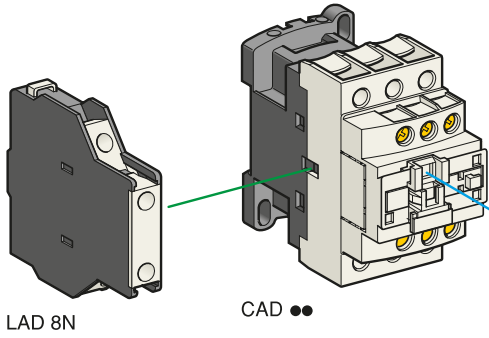

Control relays

See page opposite for mounting possibilities according to control relay type and rating



PB114200_R.eps

CAD50●●



PB114188_R.eps

CAD503●●



PB121538_eps

LADN22



PB121530_eps

LA1DY20

Control relays for connection by screw clamp terminals

Type	Number of contacts	Composition	Basic reference, to be completed by adding the control voltage code ⁽¹⁾
Instantaneous	5		CAD50●● ⁽³⁾
			CAD32●● ⁽³⁾

Control relays for connection by spring terminals

Instantaneous	5		CAD503●●
			CAD323●●

Instantaneous auxiliary contact blocks for connection by screw clamp terminals

For use in normal operating environments

Number of contacts	Maximum number per relay		Composition		Reference
	Clip-on mounting front	side			
2	1	–	1	1	LADN11
	–	1 on LH side	1	1	LAD8N11 ⁽⁶⁾
	1	–	2	–	LADN20
	–	1 on LH side	2	–	LAD8N20 ⁽⁶⁾
	1	–	–	2	LADN02
4 ⁽⁴⁾	–	1 on LH side	–	2	LAD8N02 ⁽⁶⁾
	1	–	2	2	LADN22 LADN22S ⁽⁷⁾
	–	–	1	3	LADN13
	–	–	4	–	LADN40
	–	–	–	4	LADN04
4 ⁽⁴⁾	1	–	3	1	LADN31
	–	–	2	2	LADC22

Including 1 N/O and 1 N/C make before break.

With dust and damp protected contacts, for use in particularly harsh industrial environments

Number of contacts	Maximum number per relay	Composition		Reference	
		Front mounting	protected ⁽⁵⁾		not protected
2	1		2	–	LA1DX20
			–	2	LA1DX02
			2	–	LA1DY20 ⁽⁸⁾
4 ⁽⁴⁾	1		2	–	LA1DZ40
			2	–	LA1DZ31

Instantaneous auxiliary contact blocks for connection by spring terminals

This type of connection is not possible for contact blocks LAD 8 and blocks with dust and damp protected contacts.

For all other instantaneous auxiliary contact blocks, add the digit 3 to the end of the references selected above.

Example: LADN11 becomes LADN113.

⁽¹⁾ Standard control circuit voltages (for other voltages, please consult your Regional Sales Office).

a.c. supply

Volts ~	24	42	48	110	115	220	230	240	380	400	415	440
50/60 Hz	B7	D7	E7	F7	FE7	M7	P7	U7	Q7	V7	N7	R7

d.c. supply (coils with integral suppression device fitted as standard)

Volts –	12	24	36	48	60	72	110	125	220	250	440
U from 0.7 to 1.25 Uc JD	BD	CD	ED	ND	SD	FD	GD	MD	UD	RD	

Low consumption (coils with integral suppression device fitted as standard)

Volts –	5	12	20	24	48	110	220	250
Code	AL	JL	ZL	BL	EL	FL	ML	UL

⁽²⁾ LC: low consumption.

⁽³⁾ To order control relays with connection by lugs, add the digit 6 to the end of the selected reference.

Example: CAD50●● becomes CAD506●●.

⁽⁴⁾ Blocks with 4 auxiliary contacts cannot be used on low consumption control relays.

⁽⁵⁾ Product fitted with 4 earth screen continuity terminals.

⁽⁶⁾ These contact blocks are allowed with AC coil control relay only.

⁽⁷⁾ With red front face - for safety chain indication.

⁽⁸⁾ With 2 earth screen continuity poles.



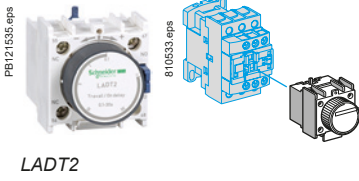

Time delay auxiliary contact blocks for connection by screw clamp terminals ⁽¹⁾

Number and type of contacts	Maximum number per relay Front mounting	Time delay		Reference
		Type	Range	
1 N/C and 1 N/O	1	On-delay	0.1...3 s ⁽²⁾	LADT0
			0.1...30 s	LADT2
			10...180 s	LADT4
		Off-delay	1...30 s ⁽³⁾	LADS2
			0.1...3 s ⁽²⁾	LADR0
			0.1...30 s	LADR2
			10...180 s	LADR4

(Sealing cover: see page B8/28)

Time delay auxiliary contact blocks for connection by spring terminals

Add the digit 3 to the references selected above. Example: LADT0 becomes LADT03.

Mechanical latch blocks ⁽⁴⁾

Unlatching control	Maximum number per relay Front mounting	Basic reference to be completed ⁽⁵⁾
Manual or electric	1	LAD6K10●

Suppressor modules

These modules clip onto the top of the control relay and the electrical connection is instantly made. Fitting of an input module is still possible.

RC circuits (Resistor-Capacitor)

- Effective protection for circuits highly sensitive to "high frequency" interference.
- Voltage limited to 3 Uc maximum and oscillating frequency limited to 400 Hz maximum.
- Slight time delay on drop-out (1.2 to 2 times the normal time).

For mounting on	Operational voltage	Reference
CAD ~	~ 24...48 V	LAD4RCE
	~ 50...127 V	LAD4RCG
	~ 110...250 V	LAD4RCU

Varistors (peak limiting)

- Protection provided by limiting the transient voltage value to 2Uc maximum.
- Maximum reduction of transient voltage peaks.
- Slight time delay on drop-out (1.1 to 1.5 times the normal time).

CAD ~	Operational voltage	Reference
CAD ~	~ 24...48 V	LAD4VE
	~ 50...127 V	LAD4VG
	~ 110...250 V	LAD4VU

Freewheel diode

- No overvoltage or oscillating frequency.
- Increase in drop-out time (6 to 10 times the normal time).
- Polarised component.

CAD ---	Operational voltage	Reference
CAD ---	--- 5...600 V	LAD4DDL

Bidirectional peak limiting diode ⁽⁶⁾

- Protection provided by limiting the transient overvoltage value to 2Uc maximum.
- Maximum reduction of transient voltage peaks.

CAD ~	Operational voltage	Reference
CAD ~	~ 24 V	LAD4TB
	~ 72 V	LAD4TS
CAD ---	--- 24 V	LAD4TBDL
	--- 72 V	LAD4TSDL
	--- 125 V	LAD4TGDL
	--- 250 V	LAD4TUDL
	--- 600 V	LAD4TXDL

(1) These contact blocks cannot be used on low consumption control relays.
 (2) With extended scale from 0.1 to 0.6 s.
 (3) With switching time of 40 ms ±15 ms between opening of the N/C contact and closing of the N/O contact.
 (4) Power should not be simultaneously applied or maintained to the mechanical latching block of the CAD N. The duration of the control signal to the mechanical latching block and the CAD N should be ≥ 100 ms.
 (5) Standard control circuit voltages (for other voltages, please consult your Regional Sales Office):

Volts ~ and ---	24	32/36	42/48	60/72	100	110/127	220/240	256/277	380/415
Code	B	C	E	EN	K	F	M	U	Q

(6) CAD●●--- and low consumption control relays are fitted with a built-in bi-directional peak limiting diode suppressor as standard. On control relays produced after 15th July 2004, this diode is removable. It can therefore be replaced by the user (see references LAD4T●●● above). It can also be replaced by a freewheel diode LAD4DDL. If a d.c. or low consumption control relay is used without suppression, the standard suppressor should be replaced with a blanking plug LAD9DL.

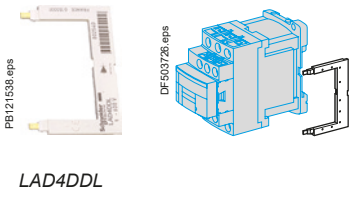
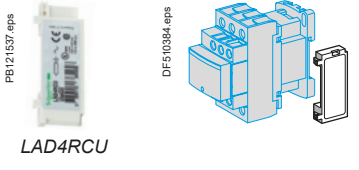
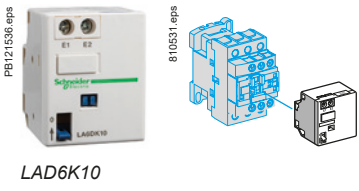

Accessories (to be ordered separately)

Description	For mounting on	Sold in lots of	Unit reference
For marking			
Sheet of 64 blank legends, self-adhesive, 8 x 33 mm	CAD, LAD (4 contacts)	10	LAD21
Sheet of 112 blank legends, self-adhesive, 8 x 12 mm	LAD (2 contacts), LADT		LAD22
Strips of blank, self-adhesive legends for printing by plotter (4 sets of 5 strips)	All products	35	LAD24
"SIS Label" labelling software for legends LAD 21 and LAD 22, supplied on CD-Rom	Multi-language version: English, French, German, Italian, Spanish	1	XBY2U
Legend holder, snap-in, 8 x 18 mm	LC1D09...38 LC1DT20...40 LADN (4 contacts) LADT, LAD R	100	LAD90

For protection

Sealing cover	LADT, LAD R	1	LA9D901
Safety cover preventing access to the moving contact carrier	CAD	1	LAD9ET1
Red cover (for safety chain indication)	CAD	1	LAD9ET1S

Spare parts: coils

Specifications

- Average consumption at 20 °C:
 - inrush ($\cos \varphi = 0.75$) 50/60 Hz: 70 VA at 50 Hz,
 - sealed ($\cos \varphi = 0.3$) 50/60 Hz: 8 VA at 60 Hz,
- Operating range ($\theta < 60$ °C): 0.85 to 1.1 U_c

Control circuit voltage U_c	Average resistance at 20 °C ± 10 %	Inductance of closed circuit	Reference ⁽¹⁾ 50/60 Hz
V	V	H	
12	6.3	0.26	LXD1J7
21 ⁽²⁾	5.6	0.24	LXD1Z7
24	6.19	0.26	LXD1B7
32	12.3	0.48	LXD1C7
36	–	–	LXD1CC7
42	19.15	0.77	LXD1D7
48	25	1	LXD1E7
60	–	–	LXD1EE7
100	–	–	LXD1K7
110	130	5.5	LXD1F7
115	–	–	LXD1FE7
120	159	6.7	LXD1G7
127	192.5	7.5	LXD1FC7
200	–	–	LXD1L7
208	417	16	LXD1LE7
220/230	539	22	LXD1M7 ⁽³⁾
230	595	21	LXD1P7
230/240	645	25	LXD1U7 ⁽⁴⁾
277	781	30	LXD1W7
380/400	1580	60	LXD1Q7
400	1810	64	LXD1V7
415	1938	74	LXD1N7
440	2242	79	LXD1R7
480	2300	85	LXD1T7
500	2499	–	LXD1S7
575	3294	–	LXD1SC7
600	3600	135	LXD1X7
690	5600	190	LXD1Y7

⁽¹⁾ The last 2 digits in the reference represent the voltage code.

⁽²⁾ Voltage for special coils fitted in control relays with serial timer module with 24 V supply.

⁽³⁾ This coil can be used on 240 V at 60 Hz.

⁽⁴⁾ This coil can be used on 230/240 V at 50 Hz and on 240 V only at 60 Hz.



LA9D901

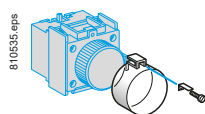

LAD9ET1S



LXD1

TeSys SK, K, D

Technical Data for Designers

Control
relays

Contents

TeSys SK:

- > characteristics B7/14 and B7/15
- > dimensions B7/16
- > schemes B7/17

TeSys K:

- > characteristics B7/18 and B7/19
- > dimensions B7/20
- > schemes B7/21

TeSys D:

- > characteristics B7/22 to B7/24
- > curves B7/25
- > dimensions B7/26
- > schemes B7/27

TeSys

TeSys SK, SKE Mini-control relays

Characteristics

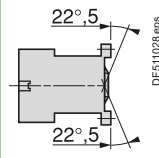
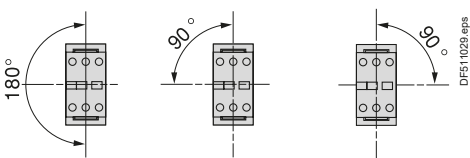
Environment				
Rated insulation voltage (Ui)	Conforming to IEC 60947, CSA 22-2 n° 14, UL 508	V	690	
Conforming to standards			IEC/EN 60947-5-1, UL 60947-5-1, CSA C22.2 n° 60947-5-1, GB/T 14048.5	
Approvals			cULus, CCC, EAC, CB certification	
Degree of protection	Conforming to IEC 60529		Protection against direct finger contact IP2X	
Ambient air temperature around the device	Storage	°C	-50...+70	
	Operation	°C	-20...+50	
Maximum operating altitude	Without derating	m	2000	
Operating position			Vertical axis  Without derating	Horizontal axis  Without derating
Connection by connectors	Solid cable	mm²	Min. 1 x 1.5 or 2 x 1.5	Max. 1 x 6 or 2 x 4
	Flexible cable without cable end	mm²	1 x 0.5 or 2 x 0.35	1 x 6 or 2 x 2.5
	Flexible cable with cable end	mm²	1 x 0.35 or 2 x 0.35	1 x 6 or 2 x 1.5
Tightening torque	Pozidriv n° 1 head	N.m	0.8	
Terminal referencing	Conforming to standards EN 50005 and EN 50011		Up to 4 contacts	
Control circuit characteristics				
Control relay			CA2SK	CA2SKE
Rated control circuit voltage (Uc)		V	~ 24...400	~ 12...72
Control voltage limits (≤ 50 °C)	For operation		0.85...1.1 Uc	
	For drop-out		≤ 0.20 Uc	
Average consumption at 20 °C and at Uc	Inrush		16 VA	23 VA
	Sealed		4.2 VA	4.9 VA
Heat dissipation		W	1.4	1.5
Operating time at 20 °C and at Uc	Between coil energisation and opening of the N/C contacts	ms	8...16	
		ms	7...14	
	Between coil de-energisation and opening of the N/O contacts	ms	6...8	
		ms	8...10	
Maximum operating rate	In operating cycles per hour		1200	1200
Mechanical durability at Uc in millions of operating cycles	50/60 Hz coil		10	–
	Standard ~ coil		–	10

Ref.



Control relays

Auxiliary contact characteristics of mini-control relays and instantaneous contact blocks

Rated operational voltage (U _e)		V	Up to 690
Rated insulation voltage (U _i)	Conforming to IEC 96047	V	690
Conventional rated thermal current (I _{th})	For ambient temperature ≤ 55 °C	A	10
Frequency of the operational current		Hz	Up to 400
Short-circuit protection	Conforming to IEC 60947, gI fuse	A	10

Operational power of contacts conforming to IEC 60947

	a.c. supply, category AC-15						d.c. supply, category DC-13						
	V	24	48	110/ 127	220/ 230	380/ 400	440	V	24	48	110	220	440
Electrical durability (valid for up to 3600 operating cycles/hour) on an inductive load such as the coil of an electromagnet: making current (cos φ 0.7) = 10 times the power broken (cos φ 0.4).							Electrical durability (valid for up to 1200 operating cycles/hour) on an inductive load such as the coil of an electromagnet, without economy resistor, the time constant increasing with the load.						
1 million operating cycles	VA	48	96	240	440	800	880	W	120	80	60	52	51
3 million operating cycles	VA	17	34	86	158	288	317	W	55	38	30	28	26
10 million operating cycles	VA	7	14	36	66	120	132	W	15	11	9	8	7
Occasional making capacity	VA	1000	2050	5000	10000	14000	13 000	W	720	600	400	300	230

Ref.



Control relays

TeSys

TeSys SK, SKE Mini-control relays

Dimensions and mounting

Dimensions

Mini-control relays

CA2SK and CA3SK

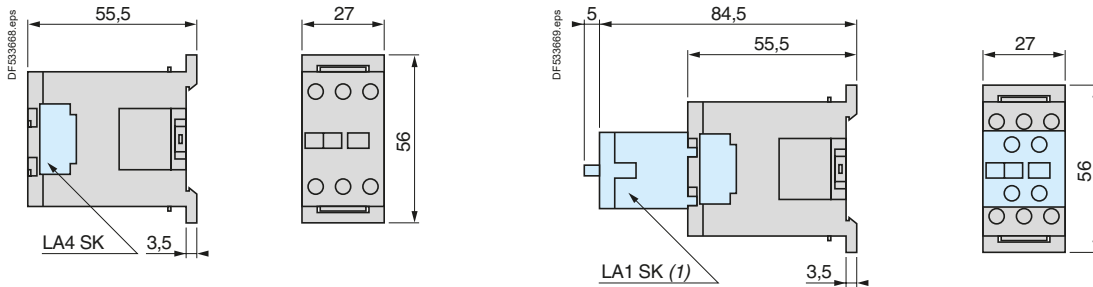

(1) Only on CA2SK20.

Mounting

Mini-control relays

CA2SK and CA3SK

On mounting rail NSYDR200BD or NSYDR200 (└ 35 mm)

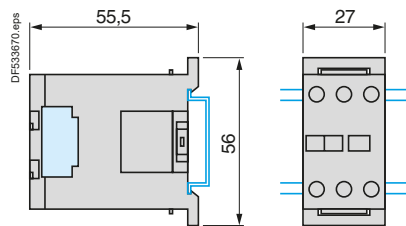

Ref.



Dimensions

CA2SKE

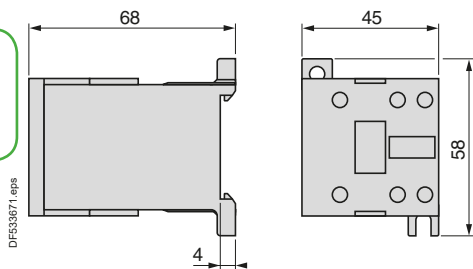

Control relays

Mounting

CA2SKE

On panel

On mounting rail NSYDR200BD or NSYDR200 (└ 35 mm)

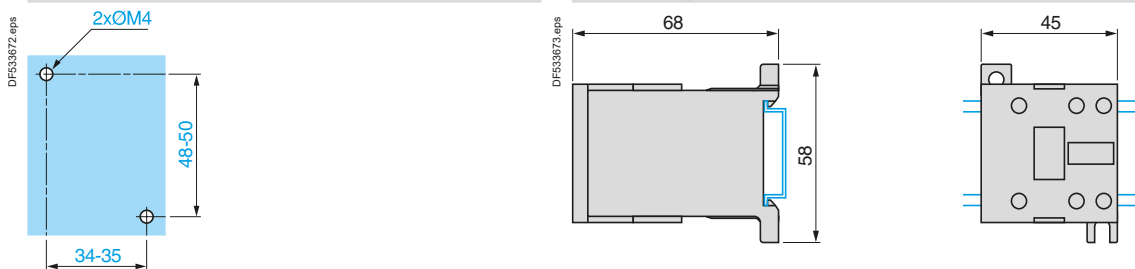

TeSys

TeSys SK, SKE Mini-control relays

Schemes

Schemes

CA2SK20, CA3SK20

2 N/O

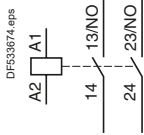

CA2SK11, CA3SK11

1 N/O + 1 N/C

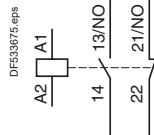

CA2SKE

2 N/O

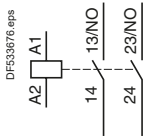

CA2SKE

Function diagram

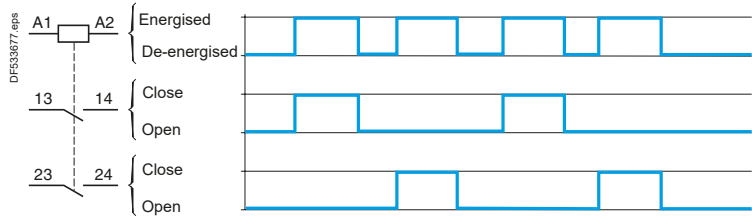

Instantaneous auxiliary contacts

2 N/O

LA1SK20

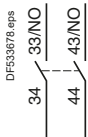

2 N/C

LA1SK02



1 N/O + 1 N/C

LA1SK11



Ref.



Control relays

TeSys

TeSys K Control relays

Characteristics

Environment

Conforming to standards		IEC/EN 60947-5-1, UL 60947-5-1, CSA C22.2 n° 60947-5-1, GB/T 14048.5			
Product certifications		UL, CSA, CCC, EAC, CB certification			
Operating positions		<div style="display: flex; justify-content: space-around;"> <div style="text-align: center;"> <p>Vertical axis</p> <p>Without derating</p> </div> <div style="text-align: center;"> <p>Horizontal axis</p> <p>Without derating</p> </div> <div style="text-align: center;"> <p>Possible positions for CA2K only, with derating, please consult your Regional Sales Office.</p> </div> </div>			
Connection		Min.	Max.	Max. to IEC 60947	
Screw clamp connections	Solid cable	mm ²	1 x 1.5	2 x 4	1 x 4 + 1 x 2.5
	Flexible cable without cable end	mm ²	1 x 0.75	2 x 4	2 x 2.5
	Flexible cable with cable end	mm ²	1 x 0.34	1 x 1.5 + 1 x 2.5	1 x 1.5 + 1 x 2.5
Spring terminals	Solid cable	mm ²	1 x 0.75	1 x 1.5	2 x 1.5
	Flexible cable without cable end	mm ²	1 x 0.75	1 x 1.5	2 x 1.5
Faston connectors	Clip	mm	2 x 2.8 or 1 x 6.35		
Solder pins for printed circuit board	With locating device between power and control circuits		4 mm x 35 microns		
Tightening torque	Philips head n° 2 and Ø6	N.m	0.8		
Terminal referencing	Conforming to standards EN 50005 and EN 50011		Up to 8 contacts		
Degree of protection	Conforming to IEC 60529		Protection against direct finger contact IP2x (devices with screw clamp terminals or pins for printed circuit board)		
Ambient air temperature around the device	Storage	°C	-50...+80		
	Operation	°C	-25...+50		
Maximum operating altitude	Without derating	m	2000		
Vibration resistance 5...300 Hz	Control relay open		2 gn		
	Control relay closed		4 gn		
Flame resistance	Conforming to IEC 60695-2-11		850 °C		
Shock resistance (1/2 sine wave, 11 ms)	Control relay open		10 gn		
	Control relay closed		15 gn		

Ref.



Control relays

Control circuit characteristics

Control relay type		CA2K	CA3K	CA4K	
Rated control circuit voltage (Uc)		V	~ 12...690	~ 12...250	~ 12...120
Control voltage limits (y 50 °C) single voltage coil	For operation		0.8...1.15 Uc	0.8...1.15 Uc	0.7...1.3 Uc
	For drop-out		≤ 0.2 Uc	≤ 0.1 Uc	≤ 0.1 Uc
Mechanical durability at Uc In millions of operating cycles	50/60 Hz coil		10	–	–
	Standard ~ coil		–	20	–
	Wide range, low consumption ~ coil		–	–	30
Maximum operating rate	In operating cycles per hour		10 000	10 000	6000
Average consumption at 20 °C and at Uc	Inrush		30 VA	3 W	1.8 W
	Sealed		4.5 VA	3 W	1.8 W
Heat dissipation		W	1.3	3	1.8
Operating time at 20 °C and at Uc	Between coil energisation and opening of the N/C contacts	ms	5...15	25...35	25...35
		ms	10...20	30...40	30...40
	Between coil de-energisation and opening of the N/O contacts	ms	10...20	10	10...20
		ms	15...25	15	15...25
Maximum immunity to microbreaks		ms	2	2	2

Contact characteristics of control relays and instantaneous contact blocks

Number of auxiliary contacts	On CA●K On LA1K		4 2 or 4 for CA2K and CA3K , 2 for CA4K	
Rated operational voltage (Ue)	Up to	V	690	
Rated insulation voltage (Ui)	Conforming to IEC 60947	V	690	
	Conforming to UL 60947-5-1, CSA C22.2 n° 60947-5-1	V	600	
Conventional thermal current (Ith)	For ambient temperature ≤ 50 °C	A	10	
Frequency of the operational current		Hz	Up to 400	
Minimum switching capacity	U min	V	17	
	I min	mA	5	
Short-circuit protection	Conforming to IEC 60947, gG fuse	A	10	
Rated making capacity	Conforming to IEC 60947			
Short-time rating	Permissible for			
		1 s	A	80
		500 ms	A	90
		100 ms	A	110
Insulation resistance		MΩ	> 10	
Non-overlap distance	CA●K and LA1K: linked contacts conforming to INRS, BIA and CNA specifications	mm	0.5 (see schemes page B7/21)	

Operational power of contacts conforming to IEC 60947

a.c. supply, category AC-15

Electrical durability (valid for up to 3600 operating cycles/hour) on an inductive load such as the coil of an electromagnet: making current ($\cos \varphi 0.7$) = 10 times the power broken ($\cos \varphi 0.4$)

d.c. supply, category DC-13

Electrical durability (valid for up to 1200 operating cycles/hour) on an inductive load such as the coil of an electromagnet, without economy resistor, the time constant increasing with the load.

	a.c. supply, category AC-15							d.c. supply, category DC-13							
	V	24	48	110/ 127	220/ 230	380/ 400	440	600/ 690	V	24	48	110	220	440	600
1 million operating cycles	VA	48	96	240	440	800	880	1200	W	120	80	60	52	51	50
3 million operating cycles	VA	17	34	86	158	288	317	500	W	55	38	30	28	26	25
10 million operating cycles	VA	7	14	36	66	120	132	200	W	15	11	9	8	7	6
Occasional making capacity	VA	1000	2050	5000	10000	14000	13000	9000	W	720	600	400	300	230	200

1 Breaking limit of contacts valid for:

- maximum of 50 operating cycles at 10 s intervals (power broken = making current x $\cos \varphi 0.7$).

2 Electrical durability of contacts for:

- 1 million operating cycles (2a)
- 3 million operating cycles (2b)
- 10 million operating cycles (2c).

3 Breaking limit of contacts valid for:

- maximum of 20 operating cycles at 10 s intervals with current passing for 0.5 s per operating cycle.

4 Thermal limit

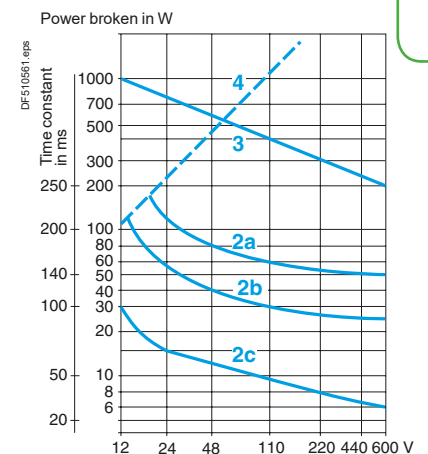
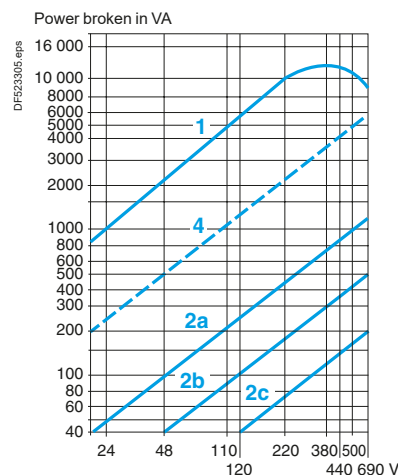

TeSys

TeSys K Control relays

Dimensions and mounting

Control relays

CA2K, CA3K, CA4K

On panel

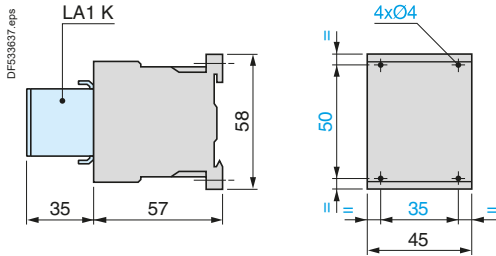

On printed circuit board

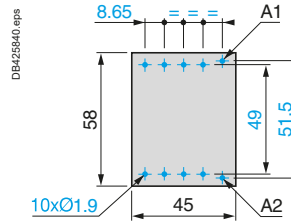

On mounting rail NSYDR200BD or NSYDR200 (L 35 mm)

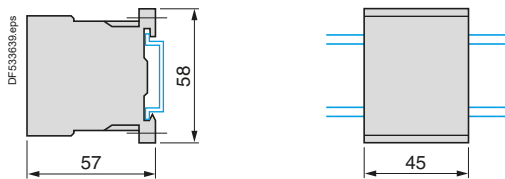

LA9D973

On asymmetrical rail with clip-on mounting plates

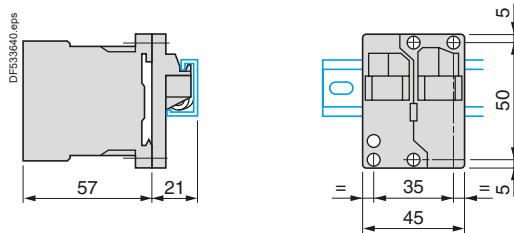

DX1AP25

On asymmetrical rail with clip-on mounting plates

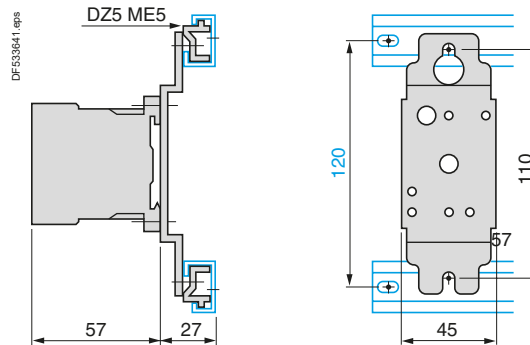

Ref.



Control relays

Electronic time delay contact blocks

LA2KT



On control relay

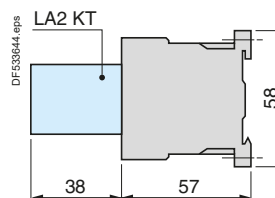

Suppressor modules

LA4K



On control relay

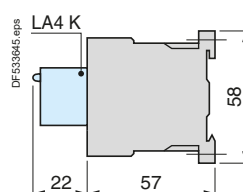

Control relays

CA2K, CA3K, CA4K

4 N/O

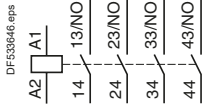

3 N/O + 1 N/C

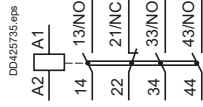

2 N/O + 2 N/C

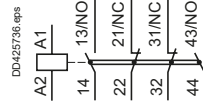

With integral suppression device

CA3K

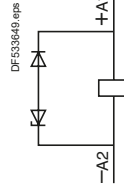

CA4K

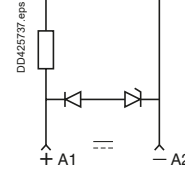

Instantaneous auxiliary contact blocks LA1K

For CA2K, CA3K, CA4K

2 N/O

LA1KN20, LA1 KN207

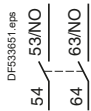

2 N/C

LA1KN02, LA1 KN027

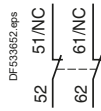

1 N/O + 1 N/C

LA1KN11, LA1 KN117



For CA2K, CA3K

4 N/O

LA1KN40, LA1 KN407

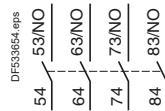

3 N/O + 1 N/C

LA1KN31, LA1 KN317

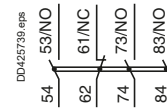

2 N/O + 2 N/C

LA1KN22, LA1KN227

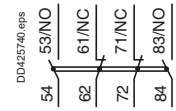

1 N/O + 3 N/C

LA1KN13, LA1KN137

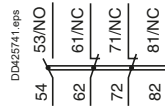

4 N/C

LA1KN04, LA1KN047

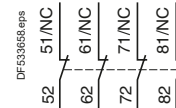

Electronic time delay contact blocks LA2KT

For CA2K, CA3K, CA4K

1 C/O

LA2KT2

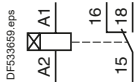

Suppressor modules

LA4KC

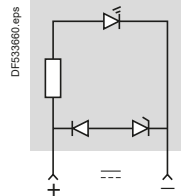

LA4KE

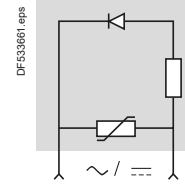

TeSys

TeSys D Control relays

Characteristics

Environment

Control relay type			CAD ~	CAD ---	CAD --- low consumption	
Rated insulation voltage (Ui)	Conforming to IEC 60947-5-1 Overvoltage category III and degree of pollution 3	V	690	690	690	
	Conforming to UL, CSA	V	600	600	600	
Rated impulse withstand voltage (Uimp)	Conforming to IEC 60947	kV	6	6	6	
Separation of electrical circuits	Conforming to IEC 60536		Reinforced insulation up to 400 V			
Conforming to standards			IEC/EN 60947-5-1, UL 60947-5-1, CSA C22.2 n° 60947-5-1, GB/T 14048.5			
Product certifications			UL, CSA, CCC, EAC, CB certification, EU-MR-RO by DNV-GL			
Degree of protection	Conforming to IEC 60529		Front face protected against direct finger contact IP 2X		Protection against direct finger contact IP 2X	
Ambient air temperature around the device	Storage	°C	-60...+80			
	Operation ⁽¹⁾	°C	-40...+60			
	Allowed ⁽¹⁾	°C	+60...+70 at Uc to 1, ●● x Uc			
Maximum operating altitude	Without derating	m	3000	3000	3000	
Operating positions	Without derating in the following positions					
		Positions that are not allowed				
Shock resistance ⁽²⁾ half sine wave for 11ms	Control relay open		10 gn	10 gn	10 gn	
	Control relay closed		15 gn	15 gn	15 gn	
Vibration resistance ⁽²⁾ 5...300 Hz	Control relay open		2 gn	2 gn	2 gn	
	Control relay closed		4 gn	4 gn	4 gn	
Screw clamp connections	Flexible conductor without cable end	1 conductor	mm²	1...4	1...4	1...4
		2 conductors	mm²	1...4	1...4	1...4
	Flexible conductor with cable end	1 conductor	mm²	1...4	1...4	1...4
		2 conductors	mm²	1...2.5	1...2.5	1...2.5
	Solid conductor without cable end	1 conductor	mm²	1...4	1...4	1...4
		2 conductors	mm²	1...4	1...4	1...4
	Tightening torque		N.m	1.7	1.7	1.7
Spring terminal connections	1 or 2 flexible or rigid conductors without cable end	mm²	1...2.5	1...2.5	1...2.5	

(1) As per IEC60947-1, operating time and drop out voltage given and tested for -5...+40 °C.
 (2) In the least favourable direction, without change of contact state, with coil supplied at Uc.

TeSys

TeSys D Control relays

Characteristics

Control circuit characteristics					
Control relay type			CAD ~	CAD ---	CAD low consumption
Rated control circuit voltage (Uc)		V	12...690	12...440	--- 5...72
Control voltage limits					
Operation	With coil 50/60 Hz		0.8...1.1 Uc at 50 Hz	–	–
			0.85...1.1 Uc at 60 Hz	–	–
	With standard coil, wide range		–	0.7...1.25 Uc	0.7...1.25 Uc
Drop-out			0.3...0.6 Uc	0.1...0.25 Uc	0.1...0.25 Uc
Average consumption at 20 °C and at Uc		~ 50/60 Hz (at 50 Hz)	VA	Inrush: 70 sealed: 8	–
	With standard coil		W	–	Inrush or sealed: 5.4 Inrush or sealed: 2.4
Operating time (at rated control circuit voltage and at 20 °C)	Between coil energisation and - opening of the N/C contacts		ms	4...19	55 ± 15 %
	- closing of the N/O contacts		ms	12...22	63 ± 15 %
	Between coil de-energisation and - opening of the N/O contacts		ms	4...12	20 ± 20 %
	- closing of the N/C contacts		ms	6...17	25 ± 20 %
Short supply failure	Maximum duration without affecting hold-in of the device		ms	2	2
Maximum operating rate	In operating cycles per second			3	3
Mechanical durability In millions of operating cycles	With coil 50/60 Hz (at 50 Hz)			30	–
	With standard coil --- wide range			–	30
Time constant L/R			ms	–	28

Ref.



Control relays

TeSys

TeSys D Control relays

Characteristics

Characteristics of instantaneous contacts incorporated in the control relay

Number of contacts			5
Rated operational voltage (Ue)	Up to	V	690
Rated insulation voltage (Ui)	Conforming to IEC 60947-5-1	V	690
	Conforming to UL, CSA	V	600
Conventional thermal current (Ith)	For ambient temperature ≤ 60 °C	A	10
Frequency of the operational current		Hz	25...400
Minimum switching capacity	U min	V	17
	I min	mA	5
Short-circuit protection	Conforming to IEC 60947-5-1		gG fuse: 10 A
Rated making capacity	Conforming to IEC 60947-5-1	I rms	~ 140, --- 250
Short-time rating	Permissible for	1 s	A 100
		500 ms	A 120
		100 ms	A 140
Insulation resistance		MΩ	> 10
Non-overlap time	Guaranteed between N/C and N/O contacts	ms	1.5 (on energisation and on de-energisation)
Tightening torque	Philips head n° 2 and Ø6	N.m	1.7
Non-overlap distance			Linked contacts in association with auxiliary contacts LADN
Mechanically linked contacts	Conforming to IEC 60947-5-1		The 3 N/O contacts and the 2 N/C contacts of CAD N32 are linked mechanically by one mobile contact carrier.

Ref.



Control relays

Rated operational power of contacts (conforming to IEC 60947-5-1)

a.c. supply, categories AC-14 and AC-15

Electrical durability (valid for up to 3600 operating cycles/hour) on an inductive load such as the coil of an electromagnet:
making current ($\cos \varphi 0.7$) = 10 times the power broken ($\cos \varphi 0.4$).

	V	24	48	115	230	400	440	600
1 million operating cycles	VA	60	120	280	560	960	1050	1440
3 million operating cycles	VA	16	32	80	160	280	300	420
10 million operating cycles	VA	4	8	20	40	70	80	100

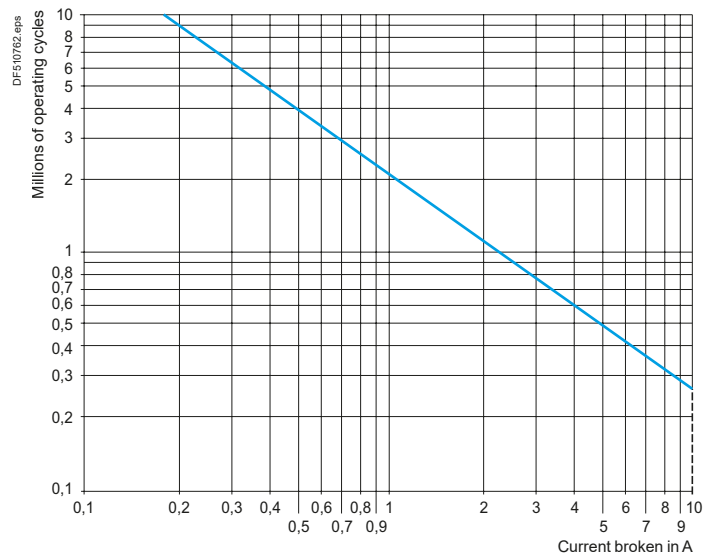

d.c. supply, category DC-13

Electrical durability (valid for up to 1200 operating cycles/hour) on an inductive load such as the coil of an electromagnet, without economy resistor, the time constant increasing with the power.

Operating cycles	V	24	48	125	250	440
1 million	W	96	76	76	76	44
3 million	W	48	38	38	32	–
10 million	W	14	12	12	–	–

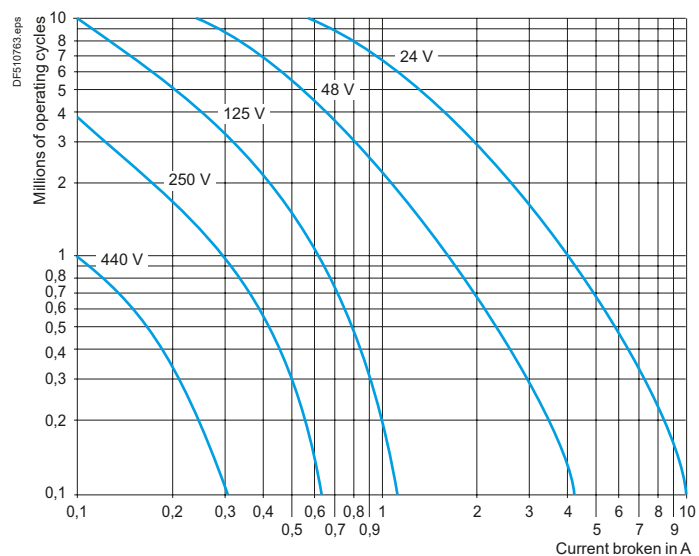

TeSys

TeSys D Control relays

Dimensions and mounting

Dimensions

CAD ~

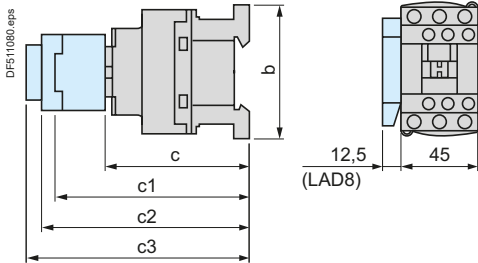

CAD --- or LC (low consumption)

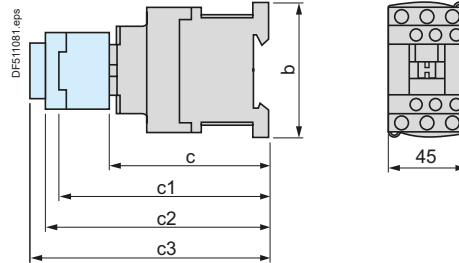

CAD	32	323
b	77	99
c without cover or add-on blocks	84	84
with cover, without add-on blocks	86	86
c1 with LADN or C (2 or 4 contacts)	117	117
c2 with LAD6K10	129	129
c3 with LADT, R, S	137	137
with LADT, R, S and sealing cover	141	141

CAD	32	323
b	77	99
c without cover or add-on blocks	93	93
with cover, without add-on blocks	95	95
c1 with LADN or C (2 or 4 contacts)	126	126
c2 with LAD6K10	138	138
c3 with LADT, R, S	146	146
with LADT, R, S and sealing cover	150	150

Operating cycles	V	24	48	125	250	440
1 million	W	120	90	75	68	61
3 million	W	70	50	38	33	28
10 million	W	25	18	14	12	10

Mounting

CAD

Panel mounted

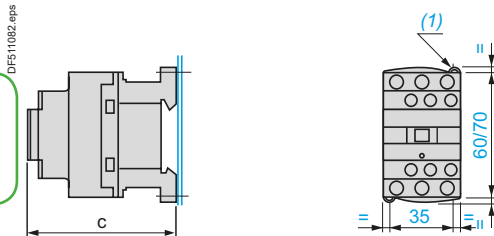

Mounted on rail NSYDR200BD or NSYDR200

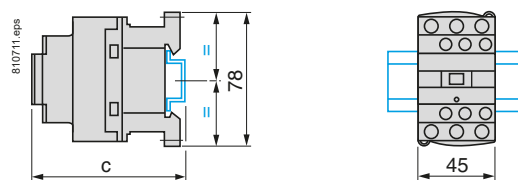

	CAD ~	CAD --- or LC
c with cover	86	95

	CAD ~	CAD --- or LC
c (NSYDR200BD) ⁽²⁾	88	97
c (NSYDR200BD) ⁽²⁾	96	105

(1) 2 elongated holes 4.5 x 9.

(2) With cover.

Mounted on plate AM1P

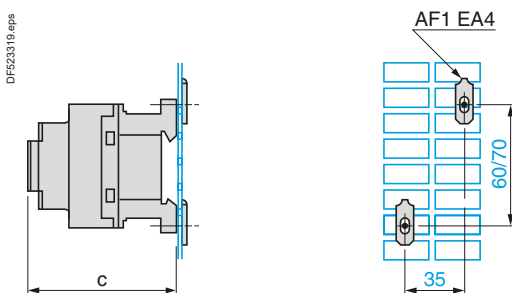

	CAD ~	CAD --- or LC
c with cover	86	95

Instantaneous auxiliary contacts

5 N/O 3 N/O + 2 N/C

CAD50

CAD32

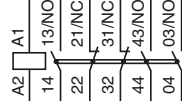
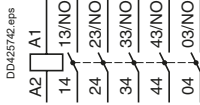

Instantaneous auxiliary contact blocks

1 N/O + 1 N/C

2 N/O

2 N/C

LADN11

LADN11 ⁽¹⁾

LADN20

LADN20 ⁽¹⁾

LADN02

LADN02

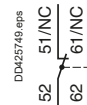
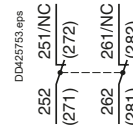
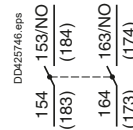
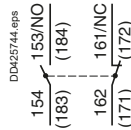
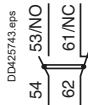

⁽¹⁾ The figures in brackets are for the device mounted on the RH side of the control relay.

2 N/O + 2F N/C

1 N/O + 3 N/C

4 N/O

4 N/C

3 N/O + 1 N/C

LADN22

LADN13

LADN40

LADN04

LADN31

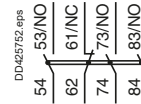
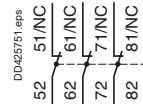
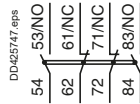
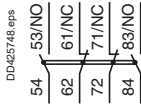

2 N/O + 2 N/C including
1 N/O + 1 N/C
make before break

With dust and damp protected contacts
2 N/O protected 2 N/C protected

2 N/O protected ⁽²⁾
with 2 cable screen
terminals

2 N/O protected +
2 N/O non protected

2 N/O protected +
1 N/O + 1 N/C
non protected

LADC22

LA1DX20

LA1DX02

LA1DY20

LA1DZ40

LA1DZ31

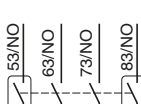
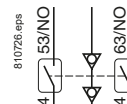
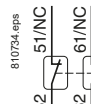

⁽²⁾ Product fitted with 4 earth screen continuity terminals.

Time delay auxiliary contact blocks

On-delay 1 N/O + 1 N/C

Mechanical latch blocks

Off-delay
1 N/O + 1 N/C

LADT

LADS

LADR

LAD6K10

