

Recessed Entertainment Box with Low Profile Frame

Parts Included:

- 1) Recessed Entertainment Box (1)
- 2) Low Profile Frame (1)
- 3) Cover Plate (1)
- 4) #10 Wood Screws (2)
- 5) #6 Screws (4)
- 6) Swing Clip (4)
- 7) #8 Screws (4)

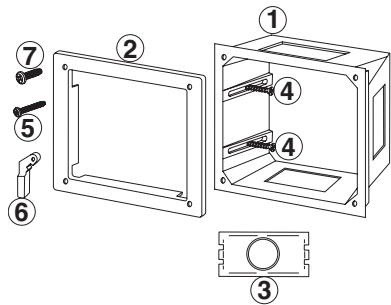

Tools needed to install your Entertainment Box:

- 1) Slotted/Phillips Screwdriver
- 2) Electrical Tape
- 3) Wallboard Saw
- 4) Pencil
- 5) Cutters
- 6) Ruler
- 7) Swedge Knife

STEP 1:

WARNING: TO AVOID FIRE, SHOCK, OR DEATH; TURN OFF POWER at circuit breaker or fuse and test that power is off before wiring!

STEP 2A:

Mounting: New Construction – Stud Mounted Installation (refer to Figures 1A and 1B):

1. Select the desired location for installation.
2. Ensure that you allow for wallboard material thickness when mounting.

NOTE: The frame will allow the hiding of minor imperfections or visible holes after mounting of wallboard around Entertainment Box. The maximum margin on the backside of the frame to cover wallboard is approximately 3/8" (0.95 cm). Refer to Figures 1A and 1B.

3. Using two (2) supplied wood screws, secure the enclosure to the stud thru the two (2) mounting slots (refer to Figure 1A).
4. After wallboard material is installed with cut-out approximately 8.0" (20.3 cm) x 7.2" (18.3 cm) in proper location, mount the low profile frame (refer to Figure 1B) or the optional high profile frame with cover (not included, refer to Figure 4) to the Entertainment Box.
5. Install four (4) #8 screws into the four frame holes to secure frame.

NOTE: The #6 screws with swing clips are used only when installing in a retrofit construction.

STEP 2B:

Retrofit Construction – Wall Mounted Installation (refer to Figures 2A and 2B):

1. Select the desired location for installation.
NOTE: This installation requires mounting the Entertainment Box in between the studs with a minimum clearance of 11.0" [27.9 cm (refer to note in Figure 2A)]. If necessary, use a stud finder to locate and mark studs that are behind surface of wall.
2. Using the front of the Entertainment Box as a template, trace the enclosure outline with a pencil on the wall surface (refer to Figure 2A). Using a wallboard saw, cut the opening out of the wallboard surface.

NOTE: Make sure that you leave enough space for a device box which may be attached to the Entertainment Box (refer to Figure 3A). If space between studs is less than 14.0" (35.6 cm), the Entertainment Box must be mounted offset from center-line of studs.

3. Select the low profile frame or the optional high profile frame with cover (not included, refer to Figure 4) for the installation. Assemble frame to Entertainment Box using the four (4) #6 screws and by placing them into the four frame holes. Attach the supplied swing clips to each screw prior to mounting (refer to Figure 2B). **DO NOT** tighten screws all the way down at this point.

NOTE: Ensure that the swing clips are placed on the screws in the orientation as depicted in Figure 2B for proper wallboard mounting.

4. Mount the Entertainment Box into the wall surface opening ensuring that the swing clips are positioned flat on box (refer to Figure 2B Detail). Secure to wallboard by tightening all four screws. Make sure the swing clips catch the wall material in all four locations (refer to Figure 2B).

STEP 3A:

Wiring Application:

Line Voltage Connections (refer to Figure 3A):

1. Use a standard Carlon 1-Gang Device Box (reference: Carlon p/n B114R).
2. Select the desired location on Entertainment Box and insert the device box from the inside. Tighten the two mounting screws on the device box to secure it to the Entertainment Box.
3. Route the electrical wires to the device box. Install the desired line voltage device to support your application needs.

NOTE: Refer to the individual device installation instructions for complete wiring instructions.

4. Install the appropriate standard size wallplate onto the device box and device, if necessary.

NOTE: If using a Decora® style wallplate, ensure that 1/4" (0.64 cm) mounting screws are used to secure wallplate.

5. Repeat steps 1 thru 4 to install additional devices in other locations. Use the Snap-on Cover Plate provided for unused openings.

STEP 3B:

Low Voltage Connections (refer to Figure 3B):

1. Use a 1-Gang Low-Voltage Bracket (reference: Levion p/n C0224 or Carlon p/n B100R) for low-voltage devices.
2. Select the desired location on Entertainment Box and insert the Low-Voltage Bracket. Tighten the two mounting screws on the Low-Voltage Bracket to secure it to the enclosure.
3. Route the low-voltage cables/wires through the bracket. Install the desired low-voltage device(s) required to support your application needs.

NOTE: Refer to the individual device installation instructions for complete wiring instructions.

4. Install the appropriate standard size wallplate onto Low-Voltage Bracket, if necessary.

NOTE: If using a Decora® style wallplate, ensure that 1/4" (0.64 cm) mounting screws are used to secure wallplate.

5. Repeat steps 1 thru 4 to install additional devices in other locations. Use the Snap-on Cover Plate provided for unused openings.

STEP 3C:

Component To Component Connections (refer to Figures 3C and 3D):

1. To route low-voltage connections from component to component, use the existing Snap-on Cover Plate.
2. Using a swedge knife, cut the knock-out from the Snap-on Cover Plate (refer to Figure 3C).

NOTE: The knock-out size is 1.25" (3.2 cm) in diameter.

3. Gently pull low-voltage wires thru hole in Snap-on Cover Plate. Snap the Cover Plate into the opening and connect wires to appropriate application.
4. Repeat steps 1 thru 4 to run additional low-voltage connections in other locations. Use the Snap-on Cover Plate provided for unused openings.

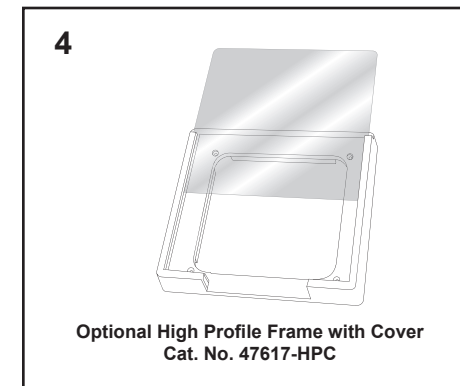
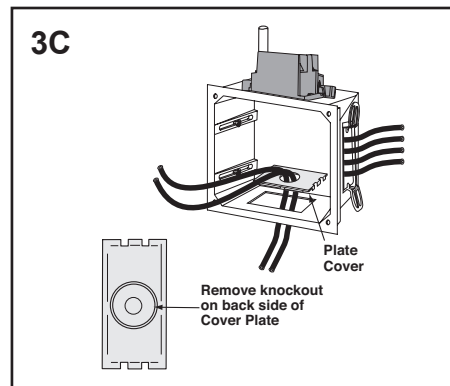
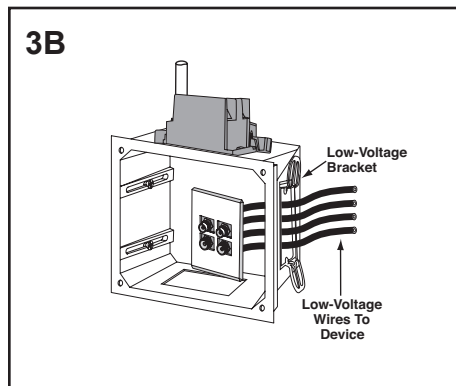
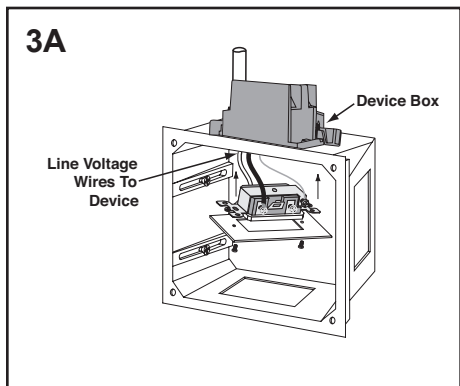
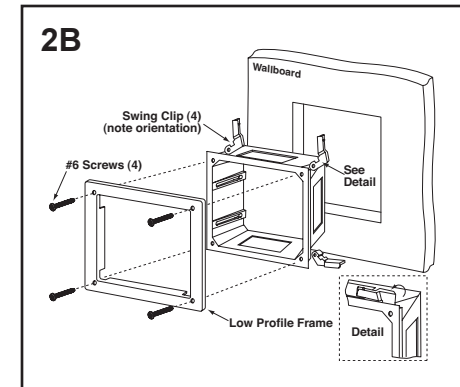
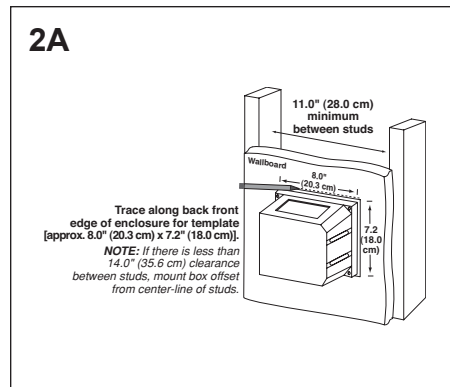
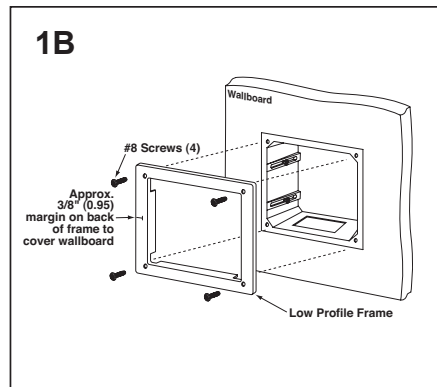
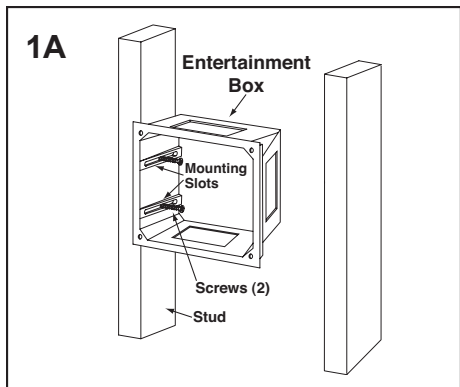

WARNINGS AND CAUTIONS:

- To be installed and/or used in accordance with appropriate electrical codes and regulations.
- If you are unsure about any part of these instructions, consult a qualified electrician.

IMPORTANT INSTRUCTIONS:

1. Read and understand all instructions. Follow all warnings and instructions marked on the product.
2. Do not use this product near water—e.g., near a tub, wash basin, kitchen sink or laundry tub, in a wet basement, or near a swimming pool.
3. Never push objects of any kind into this product through openings, as they may touch dangerous voltages.
4. **SAVE THESE INSTRUCTIONS.**

SAFETY INFORMATION:

1. Never install communications wiring or components during a lightning storm.
2. Never install communications components in wet locations unless the components are designed specifically for use in wet locations.
3. Never touch uninsulated wires or terminals unless the wiring has been disconnected at the network interface.
4. Use caution when installing or modifying communications wiring or components.
5. To prevent the possibility of electrical shock, each opening must have a device or snap-on cover plate installed.

LIMITED 5 YEAR WARRANTY AND EXCLUSIONS

Leviton warrants to the original consumer purchaser and not for the benefit of anyone else that this product at the time of its sale by Leviton is free of defects in materials and workmanship under normal and proper use for five years from the purchase date. Leviton's only obligation is to correct such defects by repair or replacement, at its option, if within such five year period the product is returned prepaid, with proof of purchase date, and a description of the problem to Leviton Manufacturing Co., Inc., Attn: Quality Assurance Department, 59-25 Little Neck Parkway, Little Neck, New York 11362-2591. This warranty excludes and there is disclaimed liability for labor for removal of this product or reinstallation. This warranty is void if this product is installed improperly or in an improper environment, overloaded, misused, opened, abused, or altered in any manner, or is not used under normal operating conditions or not in accordance with any labels or instructions. There are no other or implied warranties of any kind, including merchantability and fitness for a particular purpose, but if any implied warranty is required by the applicable jurisdiction, the duration of any such implied warranty, including merchantability and fitness for a particular purpose, is limited to five years. Leviton is not liable for incidental, indirect, special, or consequential damages, including without limitation, damage to, or loss of use of, any equipment, lost sales or profits or delay or failure to perform this warranty obligation. The remedies provided herein are the exclusive remedies under this warranty, whether based on contract, tort or otherwise.



2222 - 222nd Street SE
Bothell, WA 98021, USA
Phone: 425-486-2222
Fax: 425-483-5270