

TECHNICAL SPECIFICATIONS

TO-3060

MODEL NUMBER 141078

DIMENSIONS: 60" x 30 1/2" x 16" Gelcoat



STANDARD FEATURES

- Meets FHA accessibility requirements
- Integrated tiling flange
- 2 3/4 inch Above-the-Floor Rough available
- Textured floor
- Right or left drain
- Alcove installation
- 14 1/4 inch Deep sump
- Bottom bathing well : 45 inch L x 19 1/4 inch W

UNIQUE FEATURES

- Above-the-Floor Rough (AFR)
- Tiling Flange

OPTIONS

- None

SYSTEMS

- None

DOOR SELECTION

Combine with AKER's complete shower door offering visit www.akerbymaax.com

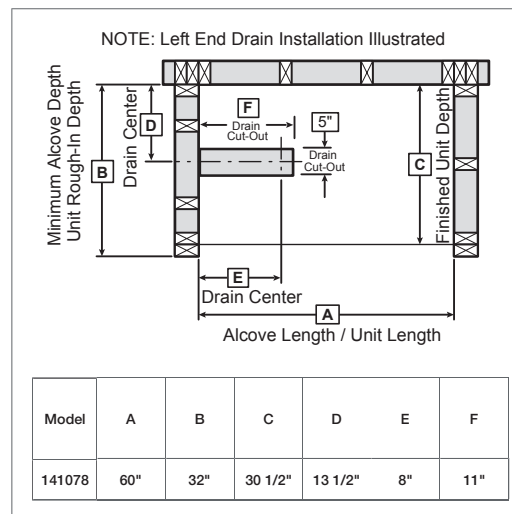

Project :

Contractor :

AKER Representative : Tel :

Date :

CERTIFICATIONS

AKER products adhere to one or more of the following certifications:



TECHNICAL SPECIFICATIONS

TO-3060

MODEL NUMBER 141078

TECHNICAL DRAWINGS

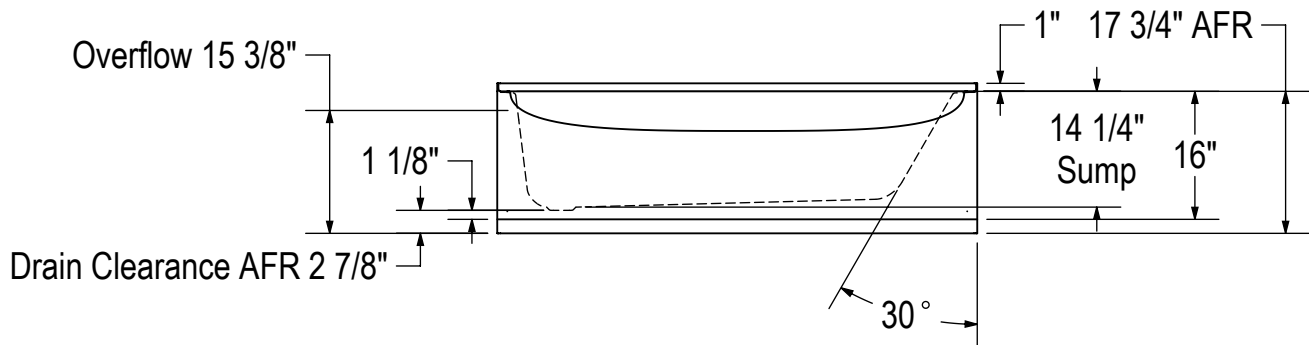
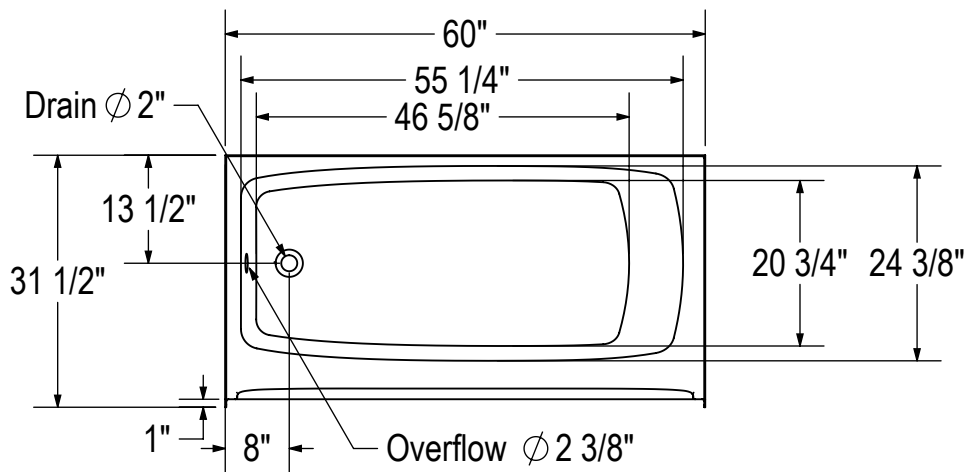

All dimensions are approximate. Structure measurements must be verified against the unit to ensure proper fit.