

TECHNICAL SPECIFICATIONS

SBF-3660

MODEL NUMBER 141089

DIMENSIONS: 60" x 36 1/2" x 21 1/4" Gelcoat



STANDARD FEATURES

- Deep and spacious bathing well
- Integrated tiling flange
- Armrests
- Deck for faucet
- 20 1/2 inch deep sump
- Bottom bathing well: 45 inch L x 25 inch W
- Textured floor
- Right or left drain
- Alcove installation

UNIQUE FEATURES

- Tiling Flange

OPTIONS

- Removable solid apron kit
- Non-removable solid apron kit
- In-line heater (factory-installed)
- Pump position opposite standard position
- Designer grab bars in Chrome
- Ozonator for whirlpool system

SYSTEMS

- Homestead Bodywrap

DOOR SELECTION

Combine with AKER's complete shower door offering visit www.akerbymaax.com

CERTIFICATIONS

AKER products adhere to one or more of the following certifications:

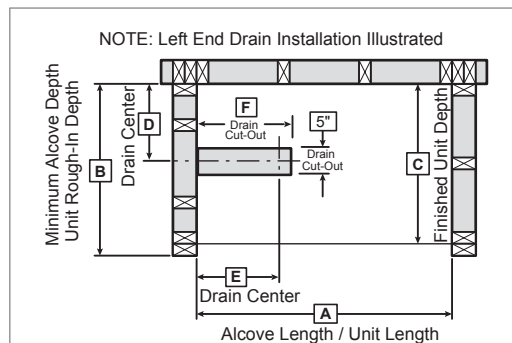

Model	A	B	C	D	E	F
141089	60"	38"	36 1/2"	17 1/4"	8 3/8"	11 3/8"

Project :

Contractor :

AKER Representative : Tel :

Date :

TECHNICAL SPECIFICATIONS

SBF-3660

MODEL NUMBER 141089

TECHNICAL DRAWINGS

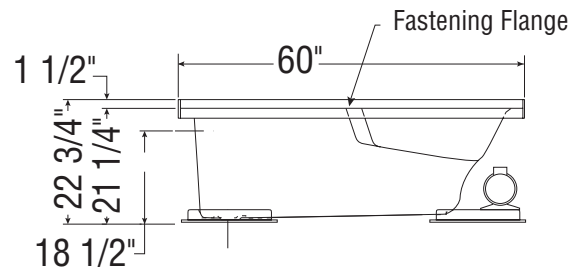
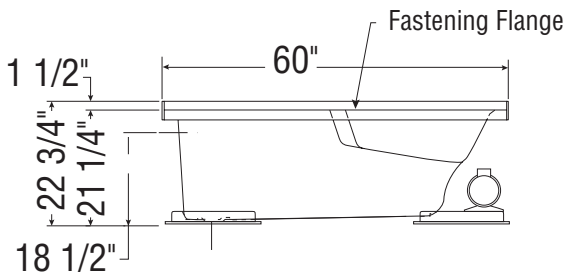
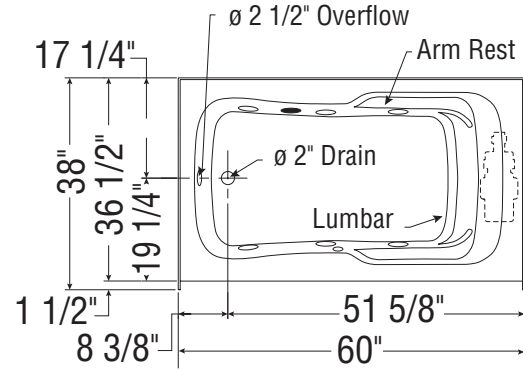
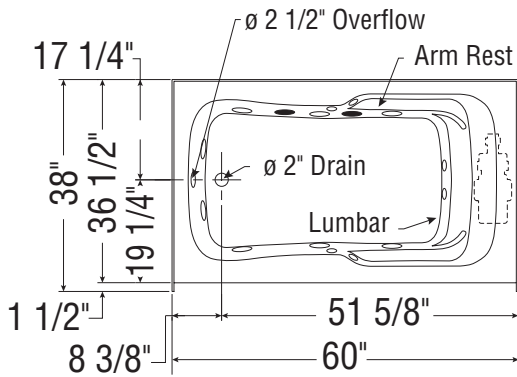

6-jet Homestead System SBF-3660L
HMS (illustrated)

10-jet Bodywrap System SBF-3660L
BWS (illustrated)