

TECHNICAL SPECIFICATIONS

SB-3660

MODEL NUMBER 141101

DIMENSIONS: 60" x 36" x 21 1/2" Gelcoat



STANDARD FEATURES

- Deep and spacious bathing well
- Backrest with lumbar support
- Armrests
- Deck for faucet
- 20 1/2 inch deep sump
- Bottom bathing well: 45 inch L x 25 inch W
- Textured floor
- End drain
- Drop-in installation

UNIQUE FEATURES

- None

OPTIONS

- Non-removable solid apron kit
- Removable solid apron kit
- In-line heater (factory-installed)
- Pump position opposite standard position
- Designer grab bars in Chrome
- Ozonator for whirlpool system

SYSTEMS

- Homestead Bodywrap

DOOR SELECTION

Combine with AKER's complete shower door offering visit www.akerbymaax.com

CERTIFICATIONS

AKER products adhere to one or more of the following certifications:



Project :

Contractor :

AKER Representative : Tel :

Date :

TECHNICAL SPECIFICATIONS

SB-3660

MODEL NUMBER 141101

TECHNICAL DRAWINGS

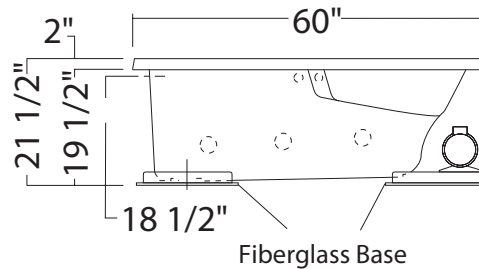
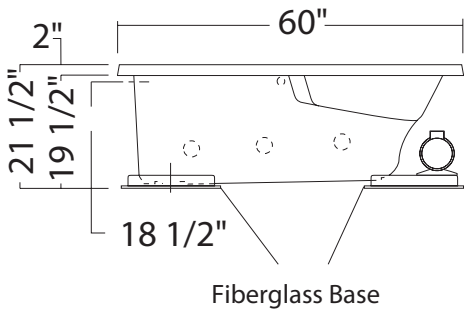
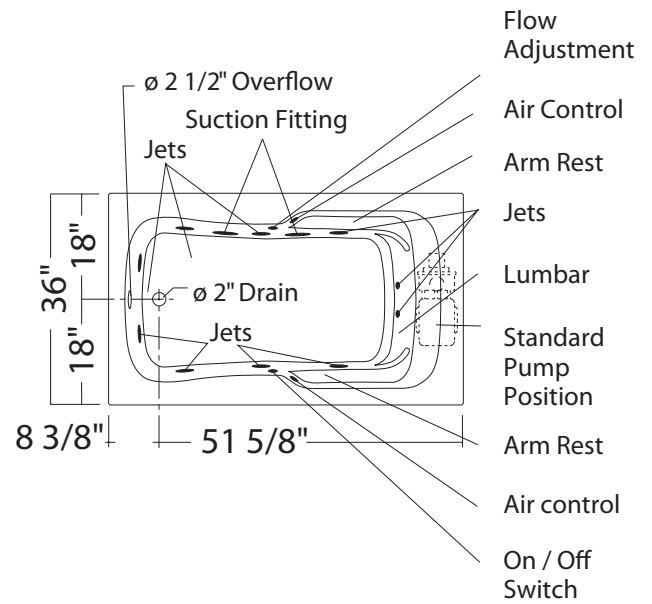
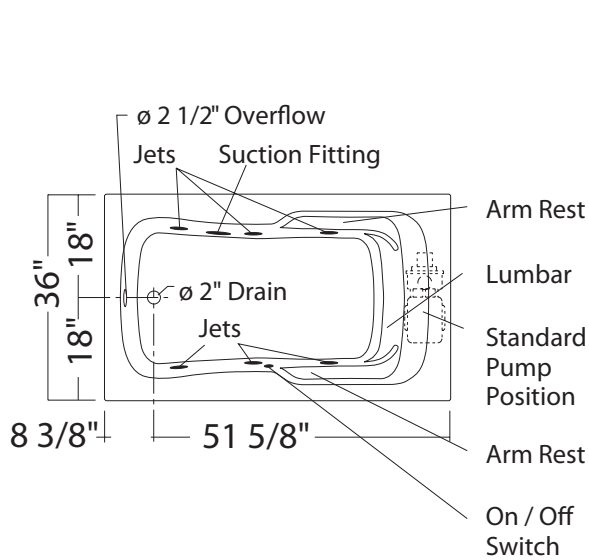

6-jet Homestead Collection SB-3660
HMS (illustrated)

10-jet Bodywrap System SB-3660
BWS (illustrated)