

**Bodyfit ACCT-6060**  
**Bodyfit CT-6060**

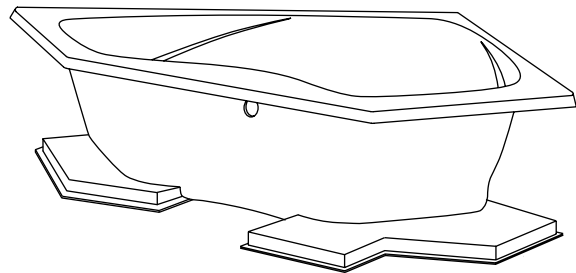

**ACC2-6060**  
**CT2-6060**

These guidelines are recommended by MAAX Aker for the proper installation of their product. A careful review of these procedures (and any referenced publications) before starting is important in avoiding unnecessary problems resulting in an improper assembly or installation.

NOTE: All drawings in this publication are typical, and may appear different than the actual items being installed. In addition, optional items may be shown on the units which may not have been ordered on the unit being installed.

**ON WHIRLPOOL EQUIPPED MODELS, A SEPARATE SET OF INSTRUCTIONS IS PACKED WITH THE UNIT FOR THE WHIRLPOOL SYSTEM. READ THEM BEFORE INSTALLING UNIT!**

**WARNING!**  
**NEVER LIFT OR HANDLE WHIRLPOOL BY SYSTEM PIPING AT ANY TIME. LIFTING THE UNIT BY THE PIPING CAN CAUSE SYSTEM DAMAGE.**

#### **Special Notes to Installer**

- ★ It is the sole responsibility of the installer to determine, prior to the installation, the requirements necessary for compliance with all codes involving the unit or the installation!
- ★ All paperwork packaged with the unit and any associated options or accessories should be saved and presented to the homeowner upon completion of the installation!
- ★ **HANDLE THE UNIT BY THE SHELL ONLY!** Never lift any unit by attachments or piping on the shell.
- ★ All published unit dimensions are for reference only. Any critical dimensions required for installation should be taken directly from the unit being installed!
- ★ Any independent changes made to the unit (or to any options and accessories supplied with the unit) beyond those required for normal installation can void all warranties! (*Refer to warranties for further information.*)

#### **Inspection Guidelines**

A careful check of the unit should be conducted upon receipt. Notify your supplier immediately if any questions or problems are encountered during this process.

**DO NOT INSTALL ANY UNIT WITHOUT FIRST ADDRESSING QUESTIONS WHICH ARISE DURING THE INSPECTION!**

#### **Basic Module Check**

- ✓ Check for unit surface damage.
- ✓ Check unit color for coordination to other bathroom fixtures.
- ✓ Check for proper options and accessories.

#### **Whirlpool and Accessories Check**

An individual system check list is included in the assembly and operational guidelines packaged with whirlpool equipped models and various accessories. Refer to the listed publications for further information before continuing.

**Unit Data and Dimensional Guidelines (Tolerance: +0 / -3/8 inch)**

**Bodyfit ACCT-6060**  
**Bodyfit CT-6060**

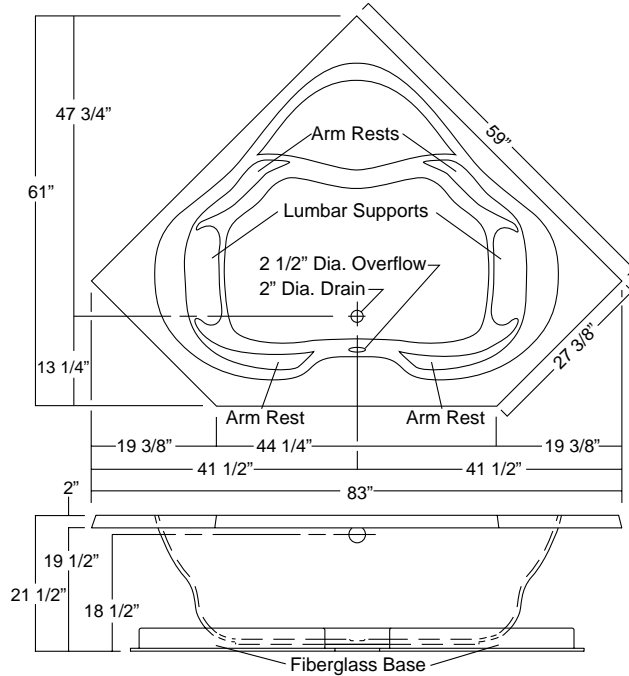

**ACC2-6060**  
**CT2-6060**

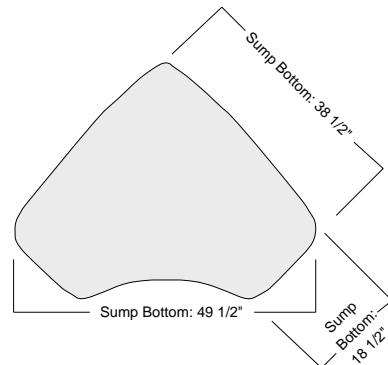
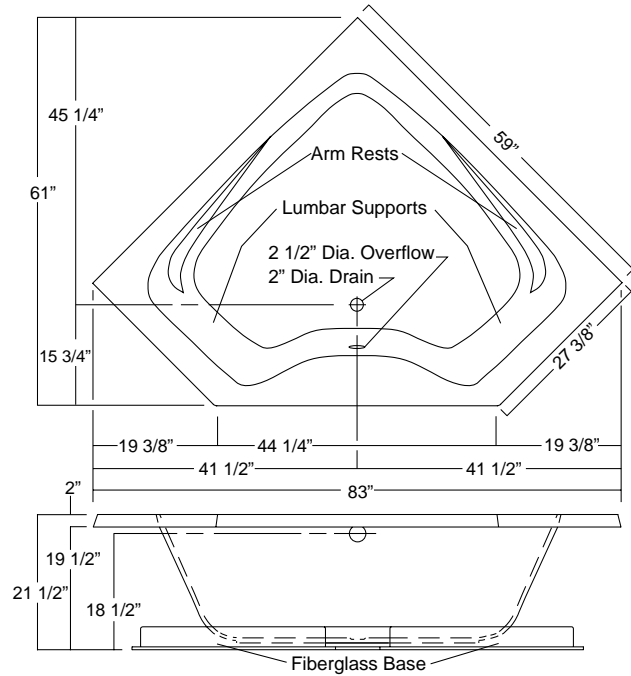

Model	Unit Surface	Sump Bottom Dim. (W x L)	Dry Unit Weight (1)	Avg. Oper. Volume	Max. Sump Capacity	Base Area	Floor Loading (2)
Bodyfit ACCT-6060	Acrylic	27 1/4 X 46 1/4 in.	181 lb.	44 gal.	88 gal.	8.5 <sup>2</sup>	85 lb/ft <sup>2</sup>
Bodyfit CT-6060	Gelcoat		157 lb.				82 lb/ft <sup>2</sup>
ACC2-6060	Acrylic	(See Special Drawing Notes)	151 lb.	74 gal.	100 gal.	8.6 <sup>2</sup>	109 lb/ft <sup>2</sup>
CT2-6060	Gelcoat		144 lb.				108 lb/ft <sup>2</sup>

1. Dry unit weight includes whirlpool system.
2. Floor loading based on an occupied whirlpool tub with an average operating volume.

**Framing Procedure**

When the installation involves a deck or platform area, framing and/or finishing the deck or platform area is **NOT RECOMMENDED** until after the unit has been secured in position.

NOTE: A pump access, shown in Figure 4, is **MANDATORY** for all whirlpool equipped modules. Additional access areas may be necessary to comply with installation site code requirements.

**Rim-to-Wall Application**

Position the unit in the bath area with the rim edge against the wall framing. Check for any framing modifications which may be required to accommodate pipes or fittings on whirlpool equipped models.

With the unit properly positioned, check the following items, illustrated in Figure 1, to the right.

- ✓ Confirm the unit base is resting flush on the floor.
- ✓ Confirm drain position.
- ✓ Confirm the unit is level along the sides, the front and at each end.

If required, place material under the base to maintain the unit in a level position. After leveling the unit, place a mark along the bottom edge of the unit rim at each framing member. Remove the unit and apply a 3/4 inch rail to the framing, positioning it about 1/16 inch below where the rim was marked (see Figures 1 and 5). **DO NOT** install the 3/4 inch rail as a rim support. On the corner seat model, additional framing members below the seat area are strongly recommended.

After repositioning and re-leveling the unit, drill and lag the base to various floor joists through the flange on the base, as shown in Figure 2.

**WARNING!**

**Self-rimming style units ARE NOT designed for insertion into a prefinished deck or platform area. Any unit damage or system failure attributed to the drop-in technique can void all warranties.**

4. Selective placement of framing members may be required to avoid damaging whirlpool system components.

2. The installation **CANNOT** allow the rim to support the weight of the unit.

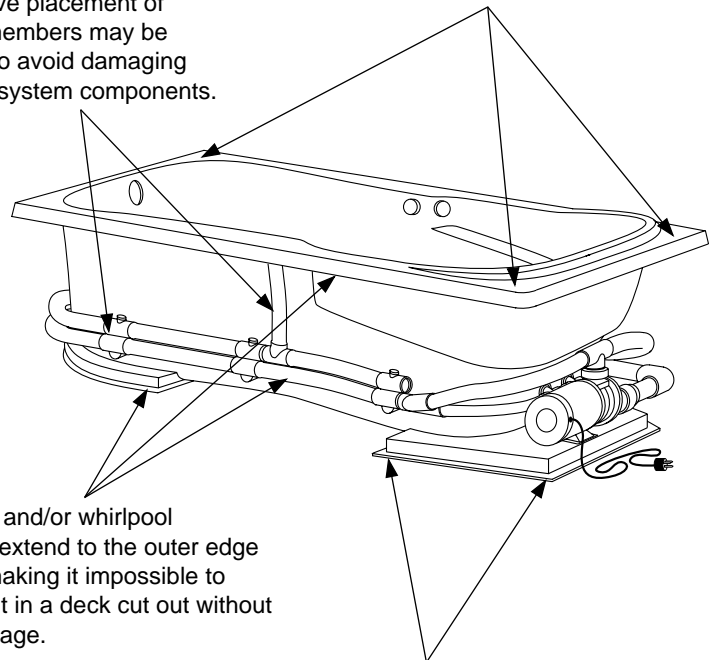

3. The base and/or whirlpool system may extend to the outer edge of the unit, making it impossible to insert the unit in a deck cut out without causing damage.

1. The base **MUST** fully rest against the floor structure and be used as the unit support.

**Figure 1 - Positioning Tub**

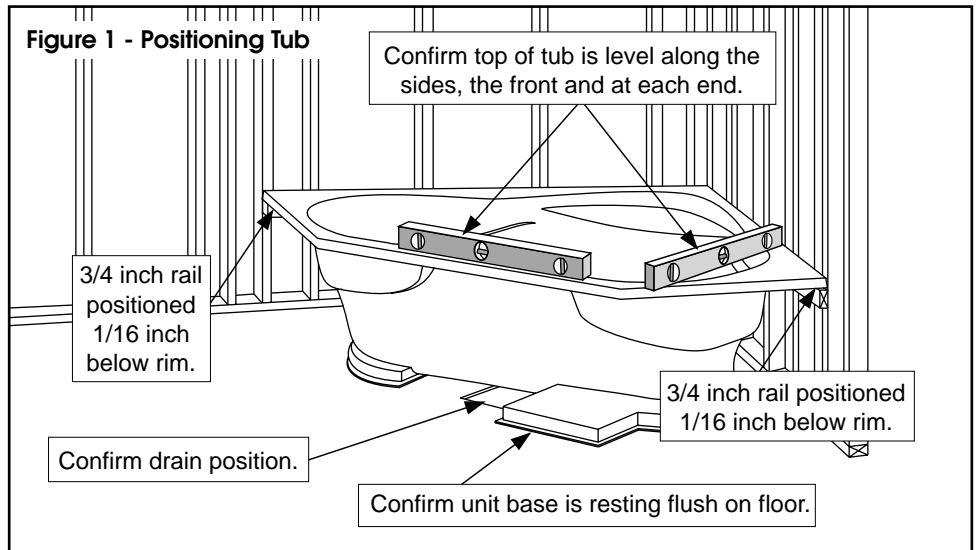

**WARNING!**  
**ANY MATERIAL PLACED UNDER THE BASE TO KEEP THE UNIT LEVEL MUST BE STRUCTURALLY SOUND AND APPLIED TO ENSURE THE UNIT'S WEIGHT WILL BE EQUALLY DISTRIBUTED OVER THE ENTIRE BASE.**

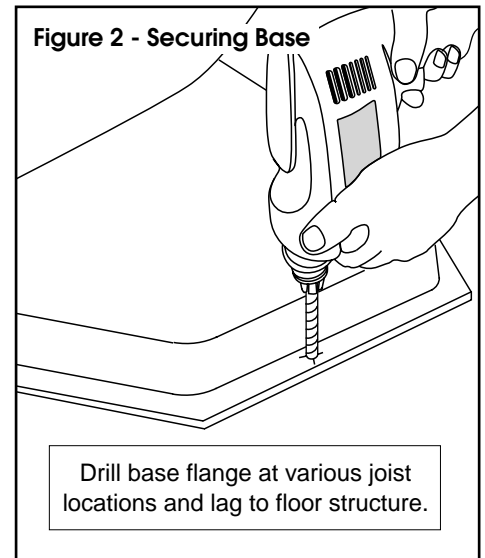
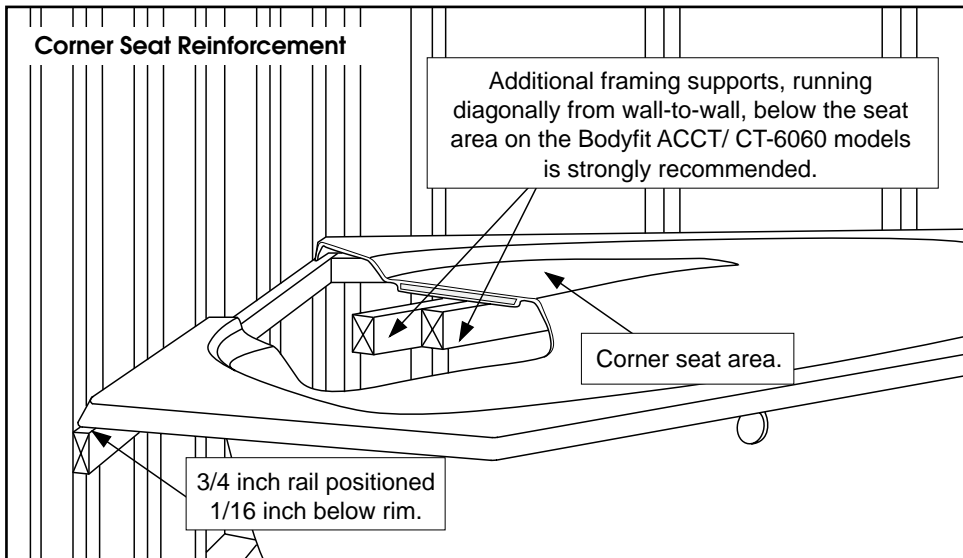

**Platform Surround Framing**

With the base secured to the floor structure, as shown in Figures 1 and 2, the framework surrounding the unit can now be constructed. Due to the design possibilities, it is impossible to provide exact guidelines for every type of installation.

The following guidelines apply to every self-rimming unit regardless of the installation configuration. A careful review of these guidelines before continuing is important in avoiding unnecessary problems resulting in an improper installation. (Figures 3, 4 & 5)

- a. All materials and construction techniques must comply with applicable codes for the installation site.
- b. All framing must be square, level, and adequately designed to provide the structural (weight bearing) support necessary for the areas use.
- c. All provided access areas must comply with applicable codes for the installation site. A service access is mandatory at the pump location on all whirlpool models for all installations. (Figure 4)
- d. Appropriate clearances between the framing and the bottom edge of the rim must be maintained for the application of underlayment and the finish material, plus a 1/16 to 1/8 inch gap to allow for application of a waterproof sealant. (Figure 5)

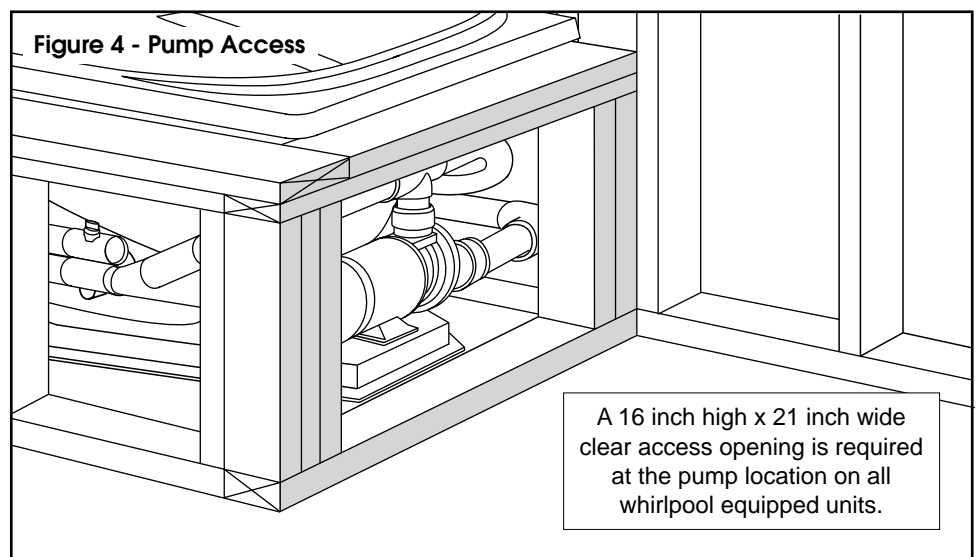
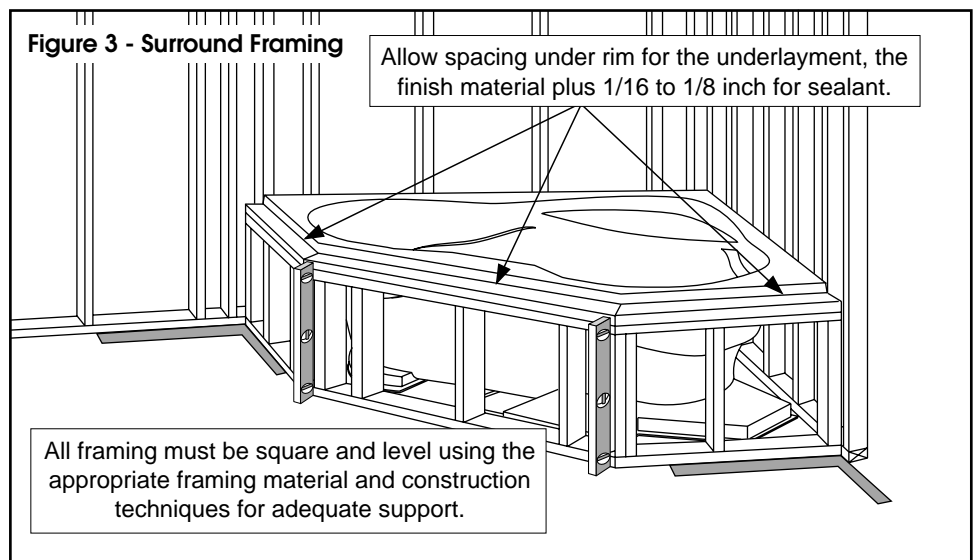

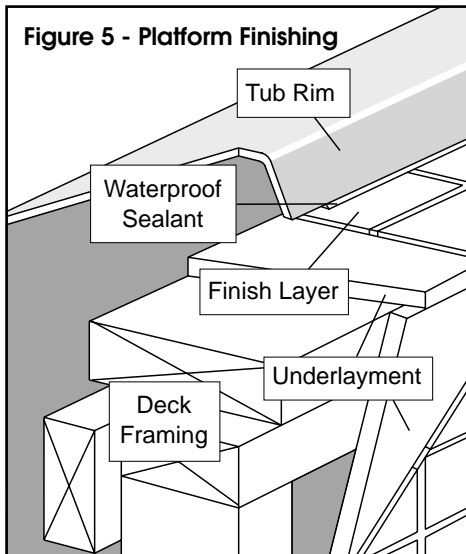

**Platform Surround Finishing**

Install and seal an appropriate underlayment for the selected finish material as instructed by the manufacturer. Make sure the underlayment extends under the tub rim far enough to provide adequate backing for the finish material. (Figure 5)

Apply the finish material and seal according to the manufacturer's specifications. (Figure 5)

After all the finish work is completed, carefully clean the area and apply an appropriate waterproof sealant between the tub rim and the finish material. Consult the sealant container for application instructions. (Figure 5)

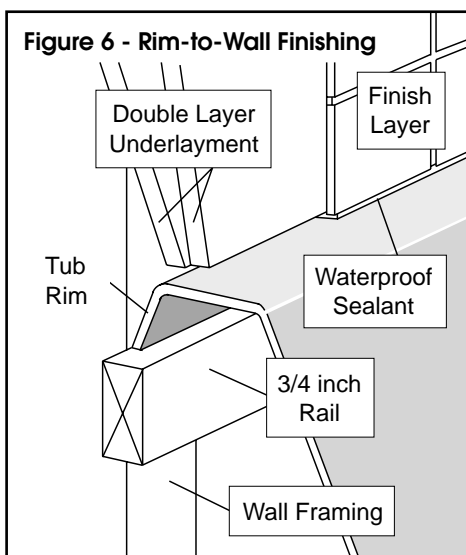

**Rim-to-Wall Finishing**

Install and seal an appropriate underlayment to wall framing for the selected finish material as instructed by the manufacturer. On rim-to-wall installations it is recommended that a double layer of underlayment be applied to insure the finish material edge will end above a flat unit surface. (Figure 6)

Apply the finish material, leaving 1/16 to 1/8 inch clearance between the finish material edge and the tub surface to allow for sealant application. (Figure 6)

After all finish work is completed, carefully clean the area and apply an appropriate waterproof sealant between the tub surface and the edge of the finish material. Consult the sealant container for application instructions. (Figure 6)

**Unit Surface Care**

**WARNING!**  
**NEVER USE ABRASIVE MATERIALS  
NOR ABRASIVE CLEANERS  
ON THE UNIT SURFACE!**

**EXTREME CAUTION is urged regarding the use of any cleaner, acid or solvent on the unit surface.**

**READ, AND FOLLOW ALL PACKAGE LABELS AND INSTRUCTIONS!**

Through routine use, the unit surface can collect residues from soap, bath additives and natural body oils. Additional deposits can also collect from minerals or particles found in the water.

After each use, wipe the excess water from the unit. This practice will reduce the build-up of deposits and help maintain the natural unit lustre.

Following a thorough surface cleaning, an application of quality automotive wax will help reduce major accumulations. The actual schedule for cleaning, and waxing, will depend on unit usage and water quality.

**WARNING!**  
**AVOID APPLYING WAX  
TO THE UNIT BOTTOM!**

◆ **Routine Cleaning:** Mild, non-abrasive cleaner specifically formulated for gelcoat and acrylic surfaces recommended. (*Rinse surface thoroughly.*)

◆ **Heavy Soap Deposits:** Liquid ammonia household cleaner, applied full strength. (*Rinse surface thoroughly.*)

◆ **Stubborn Stains:** Liquid household cleaner or hydrogen peroxide, applied full strength. Place a saturated clean rag directly on stain and let stand several hours. (*Rinse surface thoroughly.*)

For extreme cases, buff area with white automotive polishing compound until stain disappears, and apply a quality automotive wax to surface.

◆ **Hard Water Scales:** Liquid scale remover or white vinegar, applied full strength. (*Rinse surface thoroughly.*)

◆ **Mold/Mildew:** Liquid mildew remover or baking soda and water paste. Apply paste and allow to fizz several minutes. (*Rinse surface thoroughly.*)

◆ **Construction Adhesive:** Soften adhesive with hand held dryer and peel off adhesive. (*Caution is advised when using any electrical device near water.*)

For stubborn cases, apply rubbing alcohol or nail polish remover, full strength, to adhesive. (*Rinse surface thoroughly.*)

Refer to Whirlpool System Assembly and Operation Guide for guidelines on system care.

**WARNING!**  
**BATH MATS OR OTHER ITEMS WHICH ARE HELD IN PLACE USING SUCTION AGAINST THE UNIT SURFACE MUST BE REMOVED FROM THE FLOOR OF THE UNIT AFTER EACH USE.**

**OVER A PROLONGED PERIOD, FAILURE TO REMOVE THESE TYPES OF ITEMS FROM THE BOTTOM OF THE UNIT CAN RESULT IN SURFACE DAMAGE.**

MAAX Aker as the manufacturer of Bath, Tub/Shower, Shower and Whirlpool Equipped Modules, reserves the right without prior notice to:

- a. Modify the design and manufacture of its existing products or product lines without incurring any obligation to make like modifications to products previously manufactured.
- b. Add new products, product lines and/or colors and options.
- c. Discontinue existing products, product lines and/or colors and options.

Any claims, statements or contracts made regarding materials, manufacturing methods, duration and/or obligations involving MAAX Aker other than those stated in the MAAX Aker written Limited Warranty are disclaimed. Review the terms and conditions of the Limited Warranty.

Code compliance for the basic unit structure and construction is monitored by recognized groups using accepted testing and inspection procedures.

**ANSI Z 124.1 - 1995  
American National Standard  
for Plastic Bathtub Units**

MAAX Marion  
4601 Eighth Avenue  
Marion, IA 52302

MAAX Martinsburg  
718 Mid-Atlantic Parkway  
Martinsburg, WV 25401

MAAX Plymouth  
2121 Walter Glaub Dr.  
Plymouth, IN 46563

MAAX Valdosta  
1625 James P. Rodgers Road  
Valdosta, GA 31601

**GELCOATED FIBERGLASS AND VACUUM  
FORMED ACRYLIC LIMITED WARRANTY**

MAAX Aker extends to the original purchaser and subsequent consumer a limited warranty on MAAX Aker Gelcoated Fiberglass and Vacuum Formed Acrylic modules (herein called "unit") against defects in materials and/or workmanship, which results in a significantly altered appearance or affects the performance of the unit for its intended purpose during the time period stated from date of purchase.

GELCOATED FIBERGLASS UNIT.....3 YEAR DURATION  
VACUUM FORMED ACRYLIC UNIT.....10 YEAR DURATION

During this time period, MAAX Aker will, at its discretion (following inspection and verification of the claimed defect by an authorized company representative) either repair and/or refinish the unit or supply a replacement unit of comparable size and color without charge, but excluding any costs associated with the removal of and/or reinstallation of the unit. All MAAX Aker authorized and installed options and accessories are addressed under a separate warranty coverage program titled: OPTIONS AND ACCESSORIES LIMITED WARRANTY.

**THIS WARRANTY DOES NOT COVER DEFECTS RESULTING FROM:**

- (a) improper unit installation, the surrounding structure or plumbing connections beyond the recommendations supplied by MAAX Aker within the scope of applicable codes and ordinances; or
- (b) accident, abuse, misuse, negligence, fire, flood, or acts of God; or
- (c) unreasonable use, including any use beyond that intended for the unit and/or failure to follow the Care and Maintenance Instructions for the unit; or
- (d) any unauthorized alteration or modification to the unit beyond those required for normal installation, the addition of auxiliary powered devices or systems including but not limited to those which generate light, heat, or steam, or any other deviation to the unit not specifically designed for the unit, nor authorized in writing or installed by MAAX Aker; or
- (e) removal of unit from the initial installation site; or
- (f) the additions of enclosures, handicap accessories, grab bars, and/or other appliances and fittings (including installation technique) not specifically designed for the unit, nor authorized in writing or installed by MAAX Aker.

REPAIR, REFINISHING, OR THE SUPPLY OF A REPLACEMENT UNIT UNDER THIS WARRANTY SHALL BE THE EXCLUSIVE REMEDY. MAAX AKER SHALL NOT BE LIABLE FOR ANY INCIDENTAL OR CONSEQUENTIAL DAMAGES, INCLUDING ANY DAMAGE TO THE BUILDING, ITS CONTENTS OR OCCUPANTS, OR FOR BREACH OF ANY EXPRESSED OR IMPLIED WARRANTY. ANY IMPLIED WARRANTY REGARDING UNIT FITNESS FOR A PARTICULAR PURPOSE IS LIMITED IN DURATION TO THE TERMS OF THIS WARRANTY.

Some states do not allow the exclusion or limitation of incidental or consequential damages, or allow limitations on the duration of an implied warranty. Therefore, the above exclusions and/or limitations may not apply.

THIS WARRANTY PROVIDES SPECIFIC LEGAL RIGHTS, WHICH CAN VARY FROM STATE TO STATE.