

TECHNICAL SPECIFICATIONS

CT2-6060

MODEL NUMBER 141120

DIMENSIONS: 59" x 59" x 21 1/2" Gelcoat



STANDARD FEATURES

- Spacious bathing well
- 2 backrests with lumbar support
- Armrests
- Deck for faucet
- 19 3/4 inch deep sump
- Bottom bathing well: 57 inch L x 40 inch W
- Textured floor
- Center drain
- Drop-in installation

UNIQUE FEATURES

- None

OPTIONS

- In-line heater (factory-installed)
- Pump position opposite standard position
- Ozonator for whirlpool system
- Trim Kit for Bodywrap Whirlpool System

SYSTEMS

- Homestead Bodywrap

DOOR SELECTION

Combine with AKER's complete shower door offering visit www.akerbymaax.com

CERTIFICATIONS

AKER products adhere to one or more of the following certifications:



Project :

Contractor :

AKER Representative : Tel :

Date :

TECHNICAL SPECIFICATIONS

CT2-6060

MODEL NUMBER 141120

TECHNICAL DRAWINGS

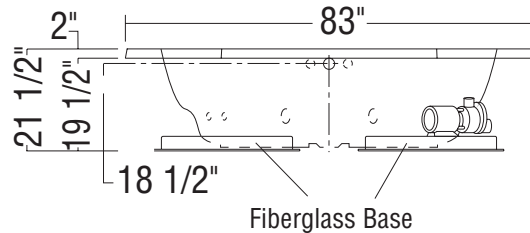
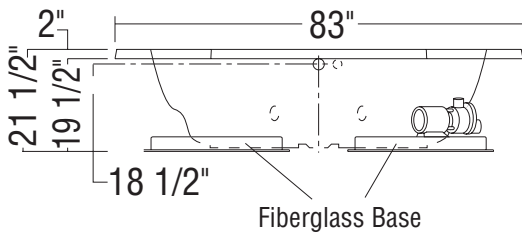
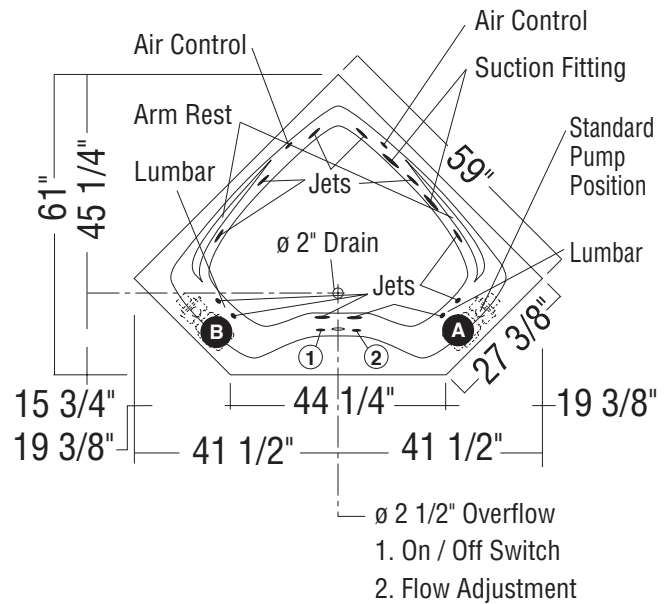
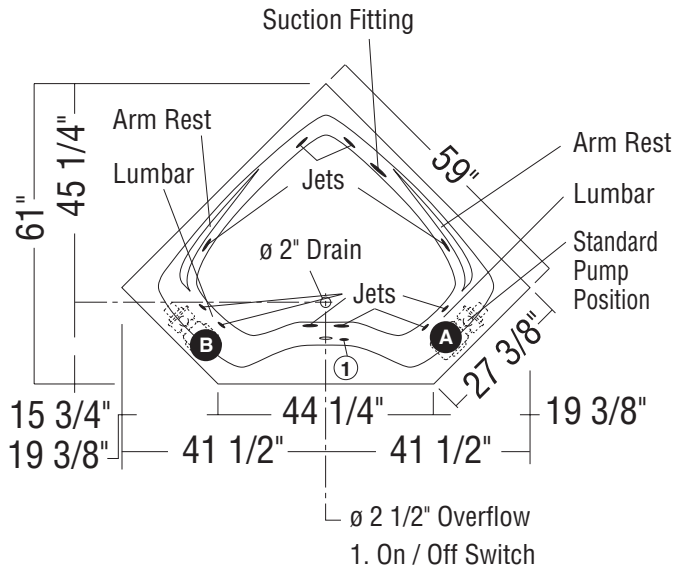

10-jet Homestead Collection CT2-6060
BWS (illustrated)

12-jet Bodywrap System CT2-6060
BWS (illustrated)