

VE-830C
 VE-810C

VE-820C



Two Handle Tub & Shower Faucet

Product Spec Sheet



FEATURES & BENEFITS

- Metal Round Handles
- Washerless Cartridges
- Non Pressure Balanced
- Diverter Slip Fit Spout
- Max Flow Rate 2.0 GPM (7.6 L/MIN) at 80 PSI (ASME A112.18.1M/A112.18.1)

VE-830C
Tub & Shower Faucet
Chrome Finish

VE-820C
Less Spout
Chrome Finish

VE-810C
Less Shower
Chrome Finish

APPROVALS:

Meets or Exceeds The Following:

* ANSI/ASME A112.18.1M/A112.18.1



* WaterSense Only On Models Containing Showerheads

CALIFORNIA:
TEXAS:
NEW YORK:

TEL: 866-532-8306
TEL: 800-935-5456
TEL: 800-431-2082

FAX: 866-532-8307
FAX: 800-683-4247
FAX: 800-640-2252

Visit Our Web Site : www.matco-norca.com

VE-830C **VE-820C**
 VE-810C



Two Handle Tub & Shower Faucet

No.	Name	Part No.
1	Shower Head	S1214202
2	Shower Arm	A020002
3	Shower Arm Flange	A019001
4	Screw	A008019
5	Washer	A080010ZN
6.1	Metal Handle-Cold	A069128C
6.2	Metal Handle-Hot	A069128H
7	Escutcheon	A111001-S
8	Sleeve	A216106
9	Stem Extension-Hot	A517000H
10	Cartridge Assembly	A66D636N
11	Seat & Spring Set	A663002
12	Union Nut	A603668
13	Spout W/Diverter	A118011
14	Spout Less Diverter	A132025
15	Hex Wrench (H 3.18 * 20 mm L * 90 mm L)	A031017NI
16	Plug	A028004

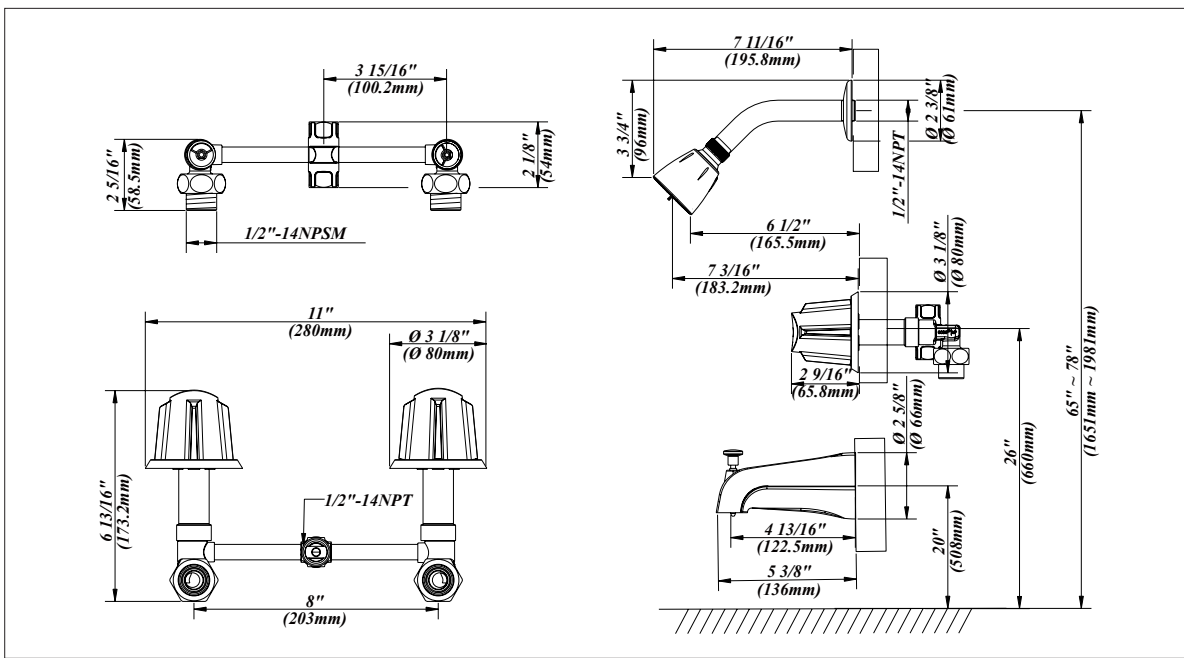
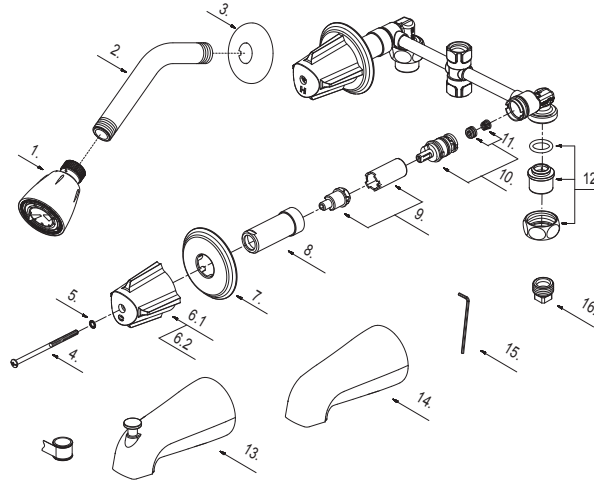

Product Spec Sheet

CALIFORNIA:
TEXAS:
NEW YORK:

TEL: 866-532-8306
TEL: 800-935-5456
TEL: 800-431-2082

FAX: 866-532-8307
FAX: 800-683-4247
FAX: 800-640-2252

Visit Our Web Site : www.matco-norca.com