

# TECHNICAL SPECIFICATIONS

## SB-3672

**MODEL NUMBER 141105**

DIMENSIONS: 72" x 36" x 21 1/2" Gelcoat



### STANDARD FEATURES

- Deep and spacious bathing well
- Backrest with lumbar support
- Armrests
- 20 1/2 inch deep sump
- Bottom bathing well: 56 1/2 inch L x 27 inch W
- Deck for faucet
- Textured floor
- End drain
- Drop-in installation

### UNIQUE FEATURES

- None

### OPTIONS

- Removable solid apron kit
- Non-removable solid apron kit
- In-line heater (factory-installed)
- Pump position opposite standard position
- Designer grab bars in Chrome
- Ozonator for whirlpool system

### SYSTEMS

- ☞ Homestead Bodywrap

### DOOR SELECTION

Combine with AKER's complete shower door offering visit [www.akerbymaax.com](http://www.akerbymaax.com)

### CERTIFICATIONS

AKER products adhere to one or more of the following certifications:



Project : .....

Contractor : .....

AKER Representative : ..... Tel : .....

Date : .....

# TECHNICAL SPECIFICATIONS

## SB-3672

MODEL NUMBER 141105

### TECHNICAL DRAWINGS

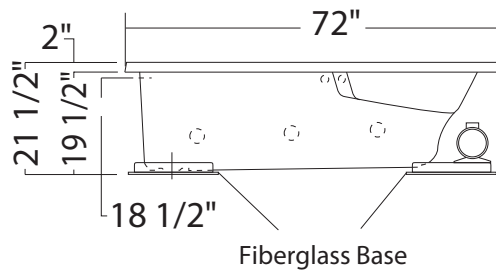
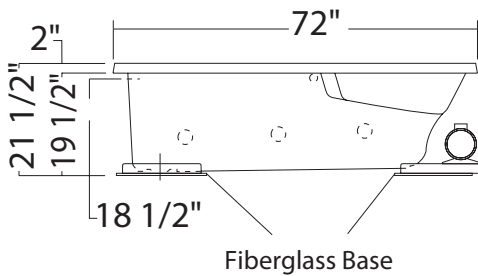
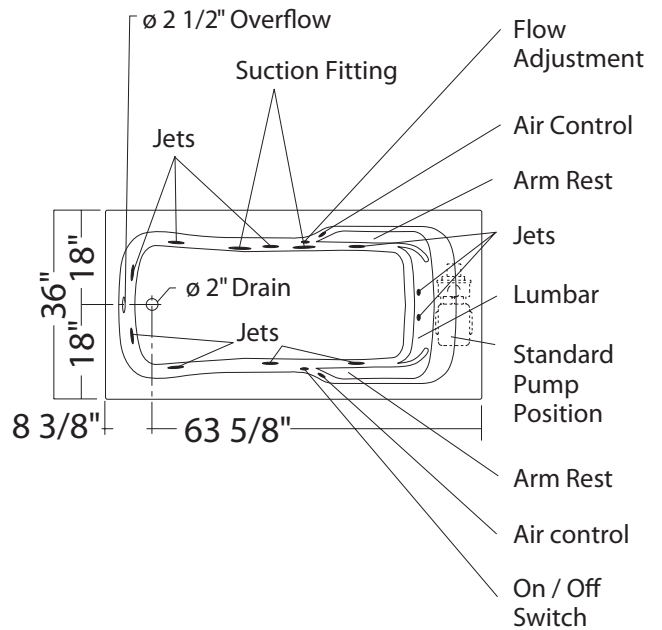
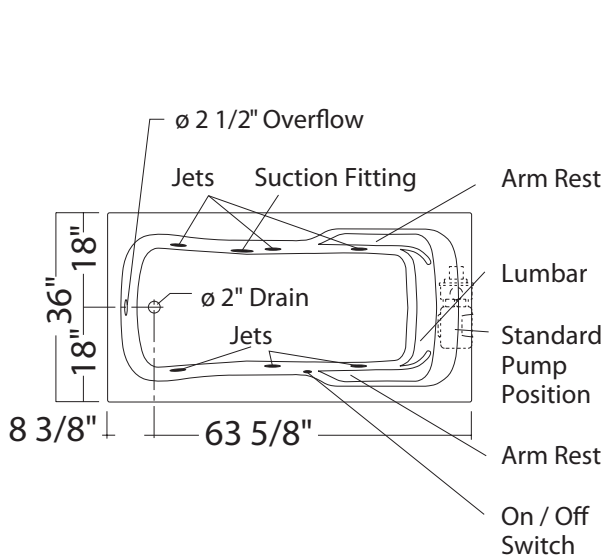

6-jet Homestead Collection SB-3672  
HMS (illustrated)

10-jet Bodywrap System SB-3672  
HMS (illustrated)