

**Submittal Package**

**Viega MegaPress FKM Fittings**



**Project** \_\_\_\_\_ **Date** \_\_\_\_\_

**Engineer** \_\_\_\_\_ **Contractor** \_\_\_\_\_

**Submitted by** \_\_\_\_\_

**Approved by** \_\_\_\_\_ **Date** \_\_\_\_\_ **Approved by** \_\_\_\_\_ **Date** \_\_\_\_\_

# Table of Contents

Chilled Water  
 Hydronic Heating  
 Fire Protection  
 Low-Pressure Steam  
 Compressed Air  
 Industrial Gases  
 Vacuum

1	<b>System Data Sheet</b> _____	<b>3</b>
	MegaPress FKM Fittings _____	3
2	<b>Product Instructions</b> _____	<b>4</b>
	MegaPress FKM ½" to 2" Fittings _____	4
	MegaPress FKM 2½" to 4" Fittings _____	5
3	<b>Engineering Specifications</b> _____	<b>6</b>
	MegaPress FKM Fittings _____	6
4	<b>Dimensional Documents</b> _____	<b>10</b>
	MegaPress FKM ½" to 2" Fittings _____	10
	MegaPress FKM 2½" to 4" Fittings _____	19
5	<b>Limited Warranty</b> _____	<b>23</b>
	MegaPress _____	23
	Metal Systems for Industrial Applications _____	24



This document is subject to updates. For the most current Viega technical literature please visit [www.viega.us](http://www.viega.us).



Viega products must be installed by trained installers. MegaPress credential training is provided at no cost by Viega and is recommended every two years. Please contact Viega to arrange credential training onsite or at our training facility.

**Installation by non-professionals may void Viega LLC's warranty.**

# 1 System Data Sheet

## MegaPress FKM Fittings



Viega MegaPress FKM is a carbon steel, cold press system designed for use in chilled water, hydronic heating, compressed air, and fire sprinkler applications.

Viega MegaPress FKM fittings are designed for use in piping systems utilizing ASTM A53, A106, A135, and A795 schedule 10 to schedule 40 carbon steel pipe.

Viega MegaPress FKM fittings in sizes from ½" to 4" are offered in configurations including: elbows, couplings, no-stop couplings, reducers, tees, reducing tees, adapters, unions, caps, and flanges.

### Components

- Alloy: carbon steel with corrosion-resistant zinc/nickel coating
- FKM sealing element
- 420 stainless steel grip ring
- 304 stainless steel separator ring for ½" to 2" fittings
- PBT separator ring for 2½" to 4" fittings

### Operating Parameters

- Operating Pressure: 200 psi max
- Test Pressure: 600 psi max
- Operating Temperatures: 14°F to 284°F  
(with temperature spikes up to 356°F)

### Listings and Certificates

- ABS type approval
- ASME B31.1, B31.3, B31.9
- BV (Bureau Veritas)
- CRN 0A14541.5 A/B/C
- DNV-GL
- FM Class 1920
- IAPMO PS117
- ICC LC1002
- Lloyds Register
- NFPA 13, 13D, 13R
- UL/ANSI 213
- ULC/ANSI ORD-C213

### Compliant with:

- ASME B31: Code for Pressure Piping
- IAPMO Uniform Mechanical Code (UMC)
- ICC International Mechanical Code (IMC)
- ICC International Residential Code (IRC)
- National Building Code of Canada (NBCC)
- National Plumbing Code of Canada (NPCC)

### Approved Applications

MegaPress FKM		
Application	Pressure (Max)	Temperature
Fire Sprinkler	175 psi	Ambient
Hydronics	200 psi	14°F to 284°F
Low Pressure Steam	Max 15 psi	Max 250°F
Fuel Oil	125 psi	Max 100°F
Industrial Gases	200 psi	Max 140°F
Compressed Air	200 psi	Max 140°F
Vacuum	Max 29.2" of Mercury	Max 140°F

For more specific information on applications for MegaPress FKM, contact Viega Technical Services at 1-800-976-9819.

Viega MegaPress FKM systems are approved for underground use and must be protected against corrosion in accordance with NFPA 54 section 404.8, NACE Standard RP0169-2002 section 5, 2009 UPC Chapter 6 section 609.3.1, 2009 UMC Chapter 13 section 1312.1.3, and in accordance with local and national codes.

### Recommended Tools

- Standard size press tool (minimum hydraulic ram output of 7200 lbs.)
- #56013 MegaPress jaw/ring kit (½" to 2")
- Viega 26200 PressBooster with 2½" MegaPress XL ring
- Viega 26201 3" and 4" MegaPress XL rings

### Smart Connect® Technology

Viega MegaPress FKM fittings are manufactured with Viega's patented Smart Connect® technology. Designed into the fitting itself, Viega Smart Connect technology allows identification of an unpressed fitting during pressure testing.



This document is subject to updates. For the most current Viega technical literature please visit [www.viega.us](http://www.viega.us).



Viega products are designed to be installed by licensed and trained plumbing and mechanical professionals who are familiar with Viega products and their installation.

**Installation by non-professionals may void Viega LLC's warranty.**

## 2 Product Instructions

### MegaPress FKM 1/2" to 2" Fittings

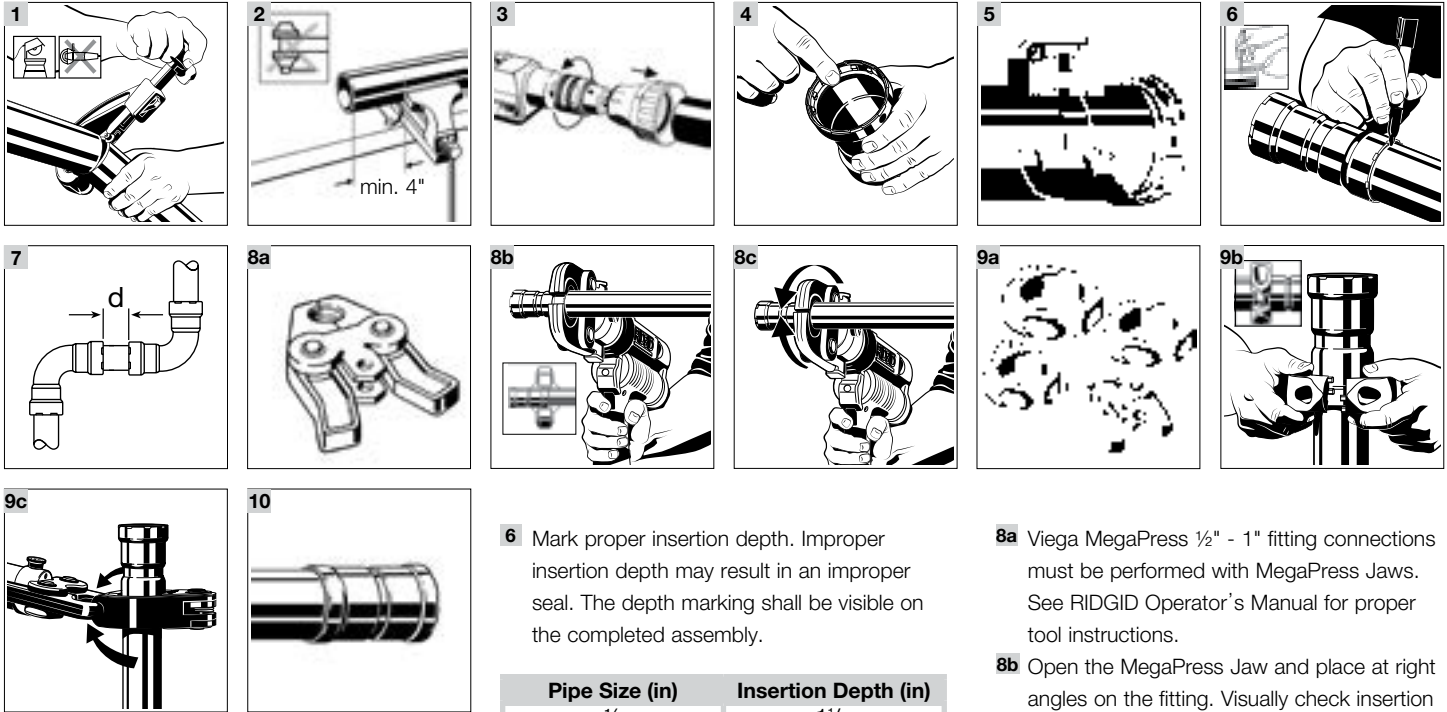

EN

### ViEga MegaPress FKM Fittings



ViEga products are designed to be installed by licensed and trained plumbing and mechanical professionals who are familiar with ViEga products and their installation. **Installation by non-professionals may void ViEga LLC's warranty.**

- 1 Cut piping at right angles using displacement type cutter.
- 2 Keep end of piping a minimum of 4" away from the contact area of the vise to prevent possible damage to the piping in the press area. See MegaPress Manual for minimum clearance required for prep tools.
- 3 Remove burr from inside and outside of piping and prep to proper insertion depth using a preparation tool or fine grit sandpaper.
- 4 Check seal and grip ring for correct fit. Do not use oils or lubricants.
- 5 Illustration demonstrates proper fit of grip ring, separation ring and sealing element.

- 6 Mark proper insertion depth. Improper insertion depth may result in an improper seal. The depth marking shall be visible on the completed assembly.

Pipe Size (in)	Insertion Depth (in)
1/2	1 1/16
3/4	1 3/16
1	1 3/8
1 1/4	1 13/16
1 1/2	1 7/8
2	2

- 7 Refer to chart for minimum distance between fittings. To ensure a correct press, a minimum distance between press fittings must be maintained. Failure to provide this distance may result in an improper seal.

Pipe Diameter (in)	d (in)	d (mm)
1/2	1/4	6
3/4	1/4	6
1	1/4	6
1 1/4	1/2	13
1 1/2	1/2	13
2	1/2	13



**Warning!**

Keep extremities and foreign objects away from press tool during pressing operation to prevent injury or incomplete press.

- 8a ViEga MegaPress 1/2" - 1" fitting connections must be performed with MegaPress Jaws. See RIDGID Operator's Manual for proper tool instructions.
- 8b Open the MegaPress Jaw and place at right angles on the fitting. Visually check insertion depth using mark on piping.
- 8c Start pressing process and hold the trigger until the jaw has engaged the fitting.
- 9a ViEga MegaPress 1 1/4" - 2" fitting connections must be performed with MegaPress Rings and V2 Actuator. See Operator's Manual for proper tool instructions.
- 9b Open MegaPress Ring and place at right angles on the fitting. MegaPress Ring must be engaged on the fitting bead. Check insertion depth.
- 9c Place V2 Actuator onto MegaPress Ring and start pressing process. Hold the trigger until the Actuator has engaged the MegaPress Ring.
- 10 Remove MegaPress Jaw from fitting or release V2 Actuator from RIDGID MegaPress Ring and then remove MegaPress Ring from the fitting on completion of press. Remove control label to indicate press has been completed.

# Product Instructions

## MegaPress FKM 2½" to 4" Fittings

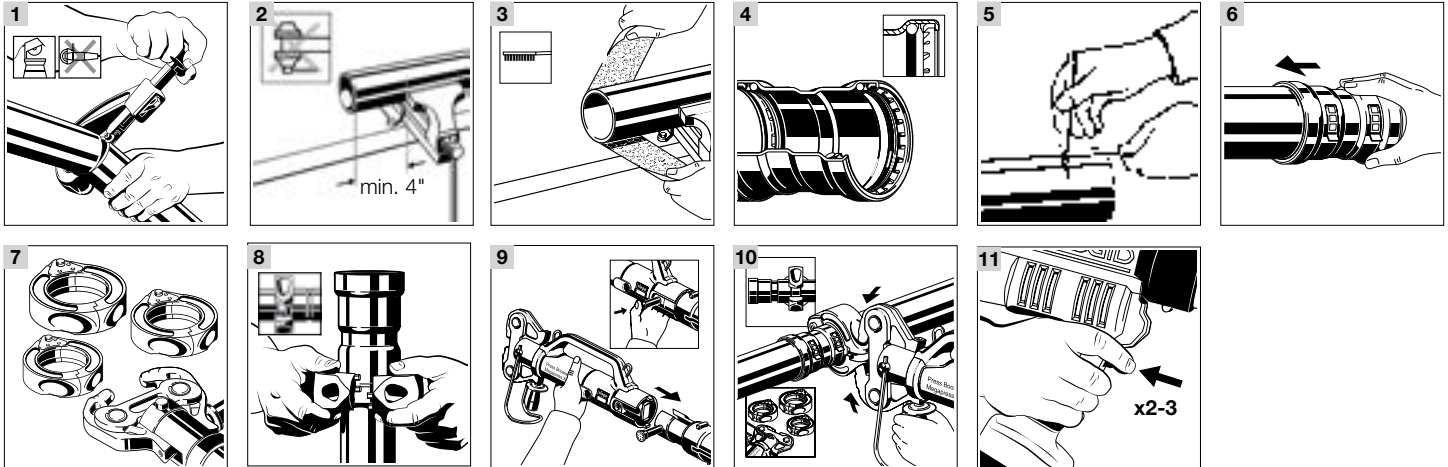

EN

### ViEga MegaPress FKM 2½" to 4"

**!** ViEga products are designed to be installed by licensed and trained plumbing and mechanical professionals who are familiar with ViEga products and their installation. **Installation by non-professionals may void ViEga LLC's warranty.**

- 1 Cut piping at right angles using displacement type cutter.
- 2 Keep end of piping a minimum of 4" away from the contact area of the vise to prevent possible damage to the piping in the press area. See MegaPress Manual for minimum clearance required for prep tools.
- 3 Remove burr from inside and outside of piping and prep to proper insertion depth using a preparation tool or fine grit sandpaper.
- 4 Illustration demonstrates proper fit of grip ring, separation ring and sealing element.

- 5 Mark proper insertion depth. Improper insertion depth may result in an improper seal. The depth marking shall be visible on the completed assembly.

Insertion Depth (in)	d (in)	d (mm)
2½	1 <sup>13</sup> / <sub>16</sub>	46
3	2 <sup>5</sup> / <sub>16</sub>	59
4	3 <sup>1</sup> / <sub>8</sub>	80

- 6 While turning slightly, slide fitting onto tubing to the marked depth. End of tubing must contact stop.

**!** **Warning!**  
Keep extremities and foreign objects away from press tool during pressing operation to prevent injury or incomplete press.

- 7 ViEga MegaPress 2½" - 4" fitting connections must be made using MegaPress XL Rings and a PressBooster/Z3 actuator. See Operator's Manual for proper tool instructions.

- 8 Open MegaPress Ring and place at right angles on the fitting. MegaPress Ring must be engaged on the fitting bead. Check insertion depth.
- 9 Remove the retaining bolt of the press machine. Slide the PressBooster in via the press jaw fixture.
- 10 Place PressBooster/Z3 actuator onto MegaPress XL Rings and start pressing process. Hold the trigger until the Actuator has engaged the MegaPress Ring.
- 11 The PressBooster requires two presses of the trigger to execute a complete press. A third press may be needed to initiate a release cycle to reset the rollers back to the original position.

# 3 Engineering Specifications

## MegaPress FKM Fittings

### Part 1: General

#### 1.1 Summary

- A. MegaPress FKM is a cold press mechanical joint fitting system utilizing standard schedule 5 to schedule 40 carbon steel pipe in sizes ½” to 4”.

#### 1.2 Definitions

- ASME: American Society of Mechanical Engineers
- ASTM: American Society for Testing and Materials
- AWWA: American Water Works Association
- CRN: Canadian Registration Number
- CSA: Canadian Standards Association
- FKM: Fluoroelastomer
- FM: Factory Mutual
- IACS: International Association of Classification Societies
- IAPMO: International Association of Plumbing & Mechanical Officials
- ICC: International Code Council
- MSS: Manufacturers Standardization Society
- NACE International: National Association of Corrosion Engineers
- NFPA: National Fire Protection Association
- UL: Underwriters Laboratory

#### 1.3 References

- ASME A13.1: Scheme for the Identification of Piping Systems
- ASME B1.20.1: Pipe Threads, General Purpose (inch)
- ASME B16.3: Malleable Iron Threaded Fittings
- ASME B16.9: Factory Made Wrought Steel Buttwelding Fittings
- ASME B31.1: Power Piping
- ASME B31.3: Process Piping
- ASME B31.9: Building Piping Systems
- ASME B36.10: Welded and Seamless Wrought Steel Pipe
- ASTM A106: Specification for Seamless Carbon Steel Pipe - High Temperature Service
- ASTM A135: Specification for Electric-Resistance-Welded Steel Pipe
- ASTM A420: Piping Fittings of Wrought Carbon Steel and Alloy Steel for Low Temperature Service
- ASTM A53: Specification for Pipe, Steel, Black and Hot-Dipped, Zinc-Coated, Welded and Seamless Pipe
- ASTM A795: Specification for Black and Hot-Dipped Zinc-Coated (Galvanized) Welded and Seamless Steel Pipe for Fire Protection Use
- ASTM D2000: Classification System for Rubber Products in Automotive Applications
- ASTM F1476: Performance of Gasketed Mechanical Couplings for Use in Piping Applications
- AWWAC651: Standard for Disinfecting Water Mains
- IACS: Requirements concerning Pipes And Pressure Vessels
- IAPMO: Uniform Mechanical Code
- IAPMO: Uniform Plumbing Code
- ICC: International Mechanical Code
- ICC: International Plumbing Code
- NACE RP 0169: Control of External Corrosion on Underground or Submerged Metallic Piping Systems
- MSS SP 58: Pipe Hangers and Supports Materials, Design and Manufacturer
- NFPA13: Standard for the Installation of Sprinkler Systems

NFPA13D: Standard for the Installation of Sprinkler Systems in One/Two Family Dwellings and Mobile Homes  
 NFPA13R: Standard for the Installation of Sprinkler Systems for Residential Occupancies up to and including Four Stories in Height  
 NFPA14: Standard for the Installation of Standpipe and Hose Systems

#### 1.4 Quality Assurance

- A. Installer shall be qualified, licensed within the jurisdiction, and familiar with the installation of cold press mechanical joint systems.
- B. MegaPress press fittings shall be installed using the proper tool, actuator, jaws and rings as instructed by the press fitting manufacturer.
- C. The installation of carbon steel pipe in sprinkler or standpipe systems shall conform to NFPA13, 13D, 13R and 14.
- D. The installation of carbon steel pipe in hydronic systems shall conform to the requirements of the ICC International Mechanical Code or the IAPMO Uniform Mechanical Code.
- E. Compliance to ASME B31.9 for building services piping.

#### 1.5 Delivery, Storage And Handling

- A. Carbon steel pipe shall be shipped to the jobsite in such a manner to protect the pipe. The pipe and fittings shall not be roughly handled during shipment. Pipe and fittings shall be unloaded with reasonable care.
- B. Protect the stored product from moisture and dirt. Elevate above grade. When stored inside, do not exceed the structural capacity of the floor.
- C. Protect fittings and piping specialties from moisture and dirt.

#### 1.6 Project Conditions

- A. Verify length of pipe required by field measurements.

#### 1.7 Warranty

- A. Viega LLC (Viega) warrants to end users, installers and distribution houses that its Viega metal press products (MegaPress) when properly installed shall be free from failure caused by manufacturing defects. Refer to Viega warranties for specific information.
- B. Viega LLC (Viega) manufacturer of the fittings shall not be responsible for the improper use, handling or installation of the product.

## Part 2: Products

### 2.1 Manufactures (Press Fittings)

- A. Viega, LLC  
 585 Interlocken Blvd.  
 Broomfield, CO 80021  
 Telephone (800) 976-9819  
 Web: [www.viega.us](http://www.viega.us)

### 2.2 Material

- A. Pipe: Carbon steel pipe shall conform to ASTM A53, A106, A135 or A795. Pipe schedule (pipe wall thickness) shall conform to the standard referenced dimensions for schedule 10 to 40.
- B. Fittings: Cold Press Mechanical Joint Fitting shall conform to material requirements of ASTM A420 or ASME B16.3 and performance criteria of IAPMO PS117. Sealing elements for press fittings shall be FKM. Sealing elements shall be factory installed or an alternative supplied by fitting manufacturer. Press ends shall have Smart Connect® technology design. MegaPress fittings with the Smart Connect technology assure leakage of liquids and/or gases from inside the system past the sealing element of an unpressed connection. The function of this technology is to provide the installer quick and easy identification of connections which have not been pressed prior to putting the system into operation.

- C. Pipe Thread: Pipe Threads shall conform to ASTM B16.3.
- D. Hangers and supports: Hangers and supports shall conform to MSS SP 58.
- E. Hanger spacing: In accordance with ASME B 31.1, NFPA54, UPC, IMC other National or local codes.

### 2.3 Source Quality Control

- A. Fittings shall be listed & approved for their intended application.
- B. All fittings used in Fire Sprinkler Applications shall be UL or FM listed.

## Part 3: Execution

### 3.1 Examination

- A. The installing contractor shall examine the pipe and fittings for defects, sand holes or cracks. There shall be no defects of the pipe or fittings. Any damaged pipe or fittings shall be rejected.
- B. The installing contractor shall insure that internal components of the cold press mechanical joint press fitting are properly in place and free from damage. This is to include sealing elements, grip ring & separator rings.

### 3.2 Preparation

- A. Carbon steel pipe shall be cut with an approved pipe cutting tool. The pipe shall be cut square to permit proper joining with the fittings.
- B. Remove scale, slag, dirt and debris from inside and outside of pipe and fittings before assembly. The protective coating shall be removed from the outside of the pipe end and shall be wiped clean and dry. The burrs on the pipe shall be reamed with a de-burring or reaming tool.

### 3.3 Installation General Locations

- A. Plans indicate general location and arrangement of piping systems. Identified locations and arrangements are used to size pipe and calculate friction loss, expansion, pump sizing and other design considerations. Install piping as indicated, except where deviations to layout are approved on coordination drawings.

### 3.4 Installation

- A. Pressure ratings: Components shall have a pressure rating equal to or greater than the system operating pressure.
- B. Install piping free of sags, bends and kinks.
- C. Change of Direction: Fittings shall be used for changes in direction and branch connections.
- D. Threaded Joints: Threaded joints shall have pipe joint compound or teflon tape applied to the male threads only. Tighten joint with a wrench and backup wrench as required.
- E. Press Fittings: MegaPress FKM cold press mechanical joint fittings shall be installed in accordance with the manufacturer's installation instructions. The protective corrosion coating shall be removed from the outside of the pipe end. The pipe shall be fully inserted into the fitting and the pipe marked at the shoulder of the fitting. The fitting alignment shall be checked against the mark on the pipe to assure the pipe is fully engaged (inserted) in the fitting. The joints shall be pressed using the tool(s) approved by the manufacturer.
- F. Pipe Protection: Pipe shall be protected against abrasion where pipe is in contact with other building members by an approved tape, pipe insulation or otherwise suitable method of isolation.
- G. Penetration Protection: Provide allowance for thermal expansion and contraction of pipe passing through a wall, floor, ceiling or partition by wrapping with an approved tape or pipe insulation or by installing through an appropriately sized sleeve. Penetrations for fire resistant rated assemblies shall maintain the rating of the assembly.
- H. Backfill Material: Backfill material shall not include any ashes, cinders, refuse, stones, boulders or other materials which can damage or break the piping or promote corrosive action in any trench or excavation in which piping is installed.
- I. Horizontal Support: Install hangers for horizontal piping in accordance with MSS SP 58.
- J. Vertical Support: Pipe shall be supported at each floor.



- K. Galvanic Corrosion: Hangers and supports shall be applicable to prevent galvanic corrosion between the system and the supporting members.
- L. Seismic Restraint: In areas where seismic conditions exist, the system shall be installed per the applicable seismic recommendations.
- M. Pipe Identification: Systems shall be identified in accordance with the requirements of ASME A13.1.

### 3.5 Field Quality Control

- A. All piping systems shall be tested per applicable local codes for joint tightness & leak detection prior to being placed in service.
- B. Water Testing: The piping system shall be water tested for joint tightness. The piping system shall be filled with water. The system shall be pressurized to the maximum pressure and length of time required by the code or standard. The system shall have no leaks at the rated pressure.
- C. Air Testing: The piping system shall be air tested for joint tightness. The piping system shall be pressurized with air to the maximum pressure of the system or to the code or standard required minimum for the required length of time. The system shall have no leaks at the rated pressure.

# 4 Dimensional Documents

## MegaPress FKM 1/2" to 2" Fittings

### MegaPress 90° Elbow, Carbon Steel, P x P - Models 4816 / 5916 / 6616

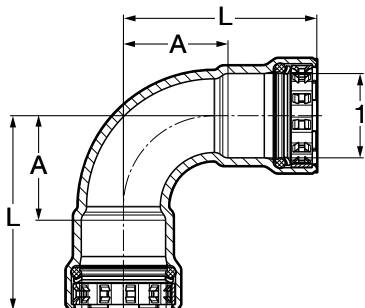

EPDM	Part No.		Size (in)	A (in)	L (in)
	FKM	HNBR			
25200	84305	25201	1/2	1.17	2.24
25205	84310	25206	3/4	1.36	2.52
25210	84315	25211	1	1.72	3.07
25215	84320	25216	1 1/4	2.00	3.82
25220	84325	25221	1 1/2	2.26	4.13
25225	84330	25226	2	2.80	4.78

### MegaPress 90° Elbow, Carbon Steel, FTG x P - Models 4816.1 / 5916.1 / 6616.1

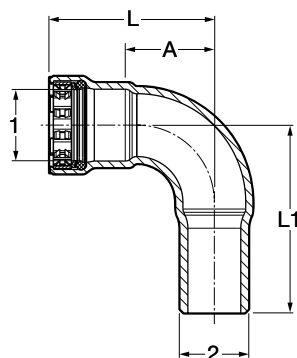

EPDM	Part No.		Size (in)	A (in)	L (in)	L1 (in)
	FKM	HNBR				
26050	84875	26051	1/2	1.17	2.24	2.56
26055	84880	26056	3/4	1.36	2.52	2.87
26060	84885	26061	1	1.72	3.07	3.39
26065	84890	26066	1 1/4	2.00	3.82	4.04
26070	84895	26071	1 1/2	2.26	4.13	4.21
26075	84900	26076	2	2.80	4.78	5.08

### MegaPress 45° Elbow, Carbon Steel, P x P - Models 4826 / 5926 / 6626

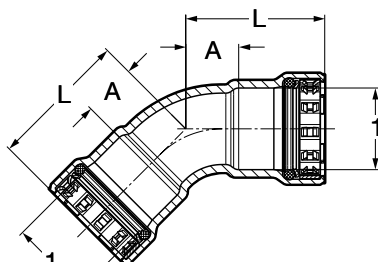

EPDM	Part No.		Size (in)	A (in)	L (in)
	FKM	HNBR			
25230	84335	25231	1/2	0.60	1.67
25235	84340	25236	3/4	0.71	1.87
25240	84345	25241	1	0.86	2.20
25245	84350	25246	1 1/4	0.98	2.80
25250	84355	25251	1 1/2	1.12	2.99
25255	84360	25256	2	1.32	3.31

**MegaPress 45° Elbow, Carbon Steel, FTG x P - Models 4826.1 / 5926.1 / 6626.1**

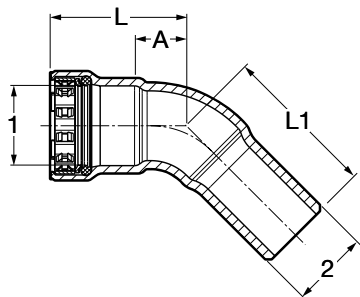

EPDM	Part No.		Size (in)	A (in)	L (in)	L1 (in)
	FKM	HNBR				
26100	84905	26101	1/2	0.60	1.67	1.97
26105	84910	26106	3/4	0.71	1.87	2.13
26110	84915	26111	1	0.86	2.20	2.52
26115	84920	26116	1 1/4	0.98	2.80	2.99
26120	84925	26121	1 1/2	1.12	2.99	3.07
26125	84930	26126	2	1.32	3.31	3.58

**MegaPress Tee, Carbon Steel, P x P x P - Models 4818 / 5918 / 6618**

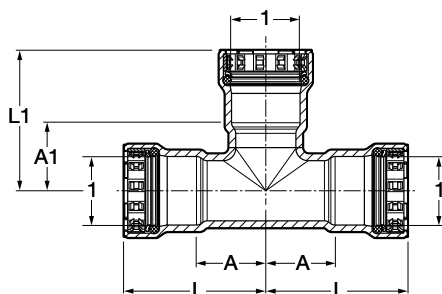

EPDM	Part No.		Size (in)	A (in)	A1 (in)	L (in)	L1 (in)
	FKM	HNBR					
25300	84365	25301	1/2	0.97	0.93	2.04	2.00
25305	84370	25306	3/4	1.11	1.09	2.26	2.24
25310	84375	25311	1	1.23	1.23	2.57	2.57
25315	84395	25316	1 1/4	1.41	1.38	3.23	3.20
25320	84400	25321	1 1/2	1.57	1.54	3.44	3.41
25325	84405	25326	2	1.81	1.80	3.80	3.79

**MegaPress Reducing Tee, Carbon Steel, P x P x P - Models 4818 / 5918 / 6618**

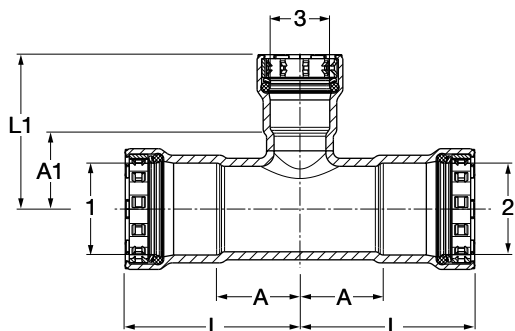

EPDM	Part No.			Size (in)			A (in)	A1 (in)	L (in)	L1 (in)
	FKM	HNBR		1	2	3				
25330	84410	25331		¾	¾	½	1.11	1.07	2.26	2.14
25335	84415	25336		1	1	½	1.23	1.20	2.57	2.28
25340	84420	25341		1	1	¾	1.23	1.24	2.57	2.40
25510	84380	25491		1¼	1¼	½	1.41	1.35	3.23	2.42
25515	84385	25496		1¼	1¼	¾	1.41	1.39	3.23	2.55
25350	84390	25351		1¼	1¼	1	1.41	1.38	3.23	2.73
25360	84425	25361		1½	1½	½	1.57	1.44	3.44	2.51
25365	84430	25366		1½	1½	¾	1.57	1.48	3.44	2.64
25370	84435	25371		1½	1½	1	1.57	1.48	3.44	2.83
25375	84440	25376		1½	1½	1¼	1.57	1.50	3.44	3.32
25380	84445	25381		2	2	½	1.81	1.74	3.80	2.81
25385	84450	25386		2	2	¾	1.81	1.80	3.80	2.95
25390	84455	25391		2	2	1	1.81	1.75	3.80	3.10
25395	84460	25396		2	2	1¼	1.81	1.78	3.80	3.60
25400	84465	25401		2	2	1½	1.81	1.84	3.80	3.71

**MegaPress Reducing Tee, Carbon Steel, P x P x FPT - Models 4817.2 / 5917.2 / 6617.2**

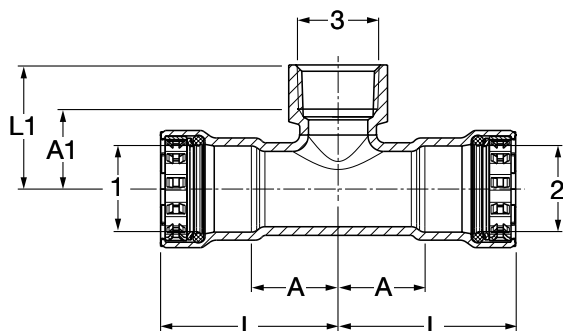

EPDM	Part No.			Size (in)			A (in)	A1 (in)	L (in)	L1 (in)
	FKM	HNBR		1	2	3				
25405	84545	25406		3/4	3/4	1/2	1.11	1.02	2.26	1.55
25480	84550	25481		3/4	3/4	3/4	1.11	1.03	2.26	1.58
25410	84555	25411		1	1	1/2	1.23	1.19	2.57	1.73
25415	84560	25416		1	1	3/4	1.23	1.18	2.57	1.73
25485	84575	25486		1 1/4	1 1/4	1/2	1.41	1.31	3.23	1.85
25505	84570	25506		1 1/4	1 1/4	3/4	1.41	1.33	3.23	1.89
25500	84565	25501		1 1/4	1 1/4	1	1.41	1.37	3.23	2.03
25435	84580	25436		1 1/2	1 1/2	1/2	1.57	1.42	3.44	1.95
25440	84585	25441		1 1/2	1 1/2	3/4	1.57	1.41	3.44	1.97
25445	84590	25446		1 1/2	1 1/2	1	1.57	1.57	3.44	2.24
25450	NA	25451		1 1/2	1 1/2	1 1/4	1.57	1.47	3.44	2.15
25455	84595	25456		2	2	1/2	1.81	1.70	3.80	2.24
25460	84600	25461		2	2	3/4	1.81	1.72	3.80	2.28
25465	84605	25466		2	2	1	1.81	1.89	3.80	2.55
25470	NA	25471		2	2	1 1/4	1.81	1.77	3.80	2.45
25475	NA	25476		2	2	1 1/2	1.81	1.73	3.80	2.41

**MegaPress Adapter, Carbon Steel, P x MPT - Models 4811 / 5911 / 6611**

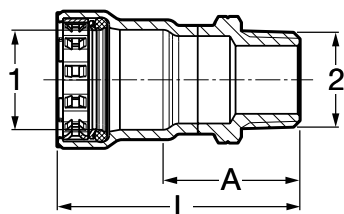

EPDM	Part No.			Size (in)		A (in)	L (in)
	FKM	HNBR	1	2			
25100	84245	25101	1/2	1/2	1.45	2.52	
25105	84250	25106	3/4	3/4	1.50	2.66	
25110	84255	25111	1	1	1.66	3.00	
25115	84260	25116	1 1/4	1 1/4	1.90	3.70	
25120	84265	25121	1 1/2	1 1/2	1.93	3.80	
25125	84270	25126	2	2	1.93	3.92	

**MegaPress Adapter, Carbon Steel, P x FPT - Models 4812 / 5912 / 6612**

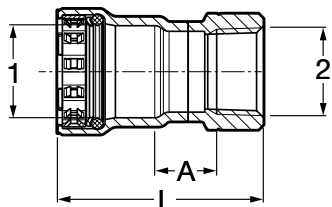

EPDM	Part No.		Size (in)		A (in)	L (in)
	FKM	HNBR	1	2		
25130	84275	25131	½ x ½		0.69	2.29
25135	84280	25136	¾ x ¾		0.74	2.45
25140	84285	25141	1 x 1		0.73	2.74
25145	84290	25146	1¼ x 1¼		0.77	3.27
25150	84295	25151	1½ x 1½		0.72	3.28
25155	84300	25156	2 x 2		0.76	3.44

**MegaPress Reducing Adapter, Carbon Steel, P x FPT - Models 4812 / 5912 / 6612**

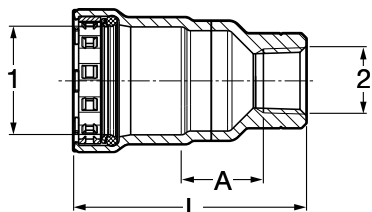

EPDM	Part No.		Size (in)		A (in)	L (in)
	FKM	HNBR	1	2		
25575	84750	25576	¾ x ½		0.73	2.43
25580	84755	25581	1 x ½		1.03	2.91
25585	84760	25586	1 x ¾		0.78	2.68
25590	84765	25591	1¼ x ½		1.15	3.50
25595	84770	25596	1¼ x ¾		1.11	3.48
25600	84775	25601	1¼ x 1		0.76	3.24
25605	84780	25606	1½ x ½		1.31	3.72
25610	84785	25611	1½ x ¾		1.27	3.70
25615	84790	25616	1½ x 1		1.11	3.64
25620	84795	25621	1½ x 1¼		0.86	3.41
25625	NA	25626	2 x ½		1.56	4.06
25630	84800	25631	2 x ¾		1.54	4.08
25635	84805	25636	2 x 1		1.35	4.00
25640	NA	25641	2 x 1¼		1.28	3.93
25645	84810	25646	2 x 1½		1.03	3.70

**MegaPress Coupling with Stop, Carbon Steel, P x P - Models 4815 / 5915 / 6615**

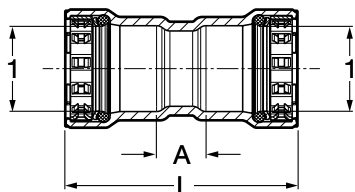

EPDM	Part No.		Size (in)		A (in)	L (in)
	FKM	HNBR	1	2		
25000	84215	25001	½		0.56	2.70
22005	84220	22009	¾		0.63	2.94
25010	84225	25011	1		0.59	3.29
25015	84230	25016	1¼		0.70	4.34
25020	84235	25021	1½		0.89	4.63
25025	84240	25026	2		0.77	4.75

**MegaPress Coupling No Stop, Carbon Steel, P x P - Models 4815.5 / 5915.5 / 6615.5**

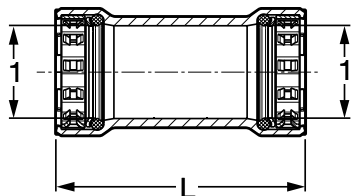

EPDM	Part No.		Size (in)		L (in)
	FKM	HNBR	1		
25030	84130	25031	1/2		2.71
25035	84135	25036	3/4		2.94
25040	84140	25041	1		3.29
25045	84145	25046	1 1/4		4.34
25050	84150	25051	1 1/2		4.63
25055	84155	25056	2		4.74

**MegaPress Extended No Stop Coupling, Carbon Steel, P x P - Models 4815.3 / 6615.3**



EPDM	Part No.		Size (in)		L (in)
	FKM	HNBR	1		
25070		25071	1/2		3.82
25075		25076	3/4		4.00
25080		25081	1		4.38
25085		25086	1 1/4		5.33
25090		25091	1 1/2		5.44
25095		25096	2		5.63

**MegaPress Reducer, Carbon Steel, FTG x P - Models 4815.1 / 5915.1 / 6615.1**

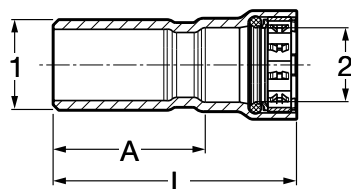

EPDM	Part No.		Size (in)		A (in)	L (in)
	FKM	HNBR	1	2		
26000	84160	26001	3/4 x 1/2		1.78	2.85
26005	84165	26006	1 x 1/2		2.14	3.21
26010	84170	26011	1 x 3/4		2.09	3.24
NA	84175	NA	1 1/4 x 3/4		2.81	3.97
26015	84180	26016	1 1/4 x 1		2.63	3.98
26020	84185	26021	1 1/2 x 3/4		2.98	4.13
26025	84190	26031	1 1/2 x 1		2.81	4.16
26030	84195	26026	1 1/2 x 1 1/4		2.70	4.52
26035	84200	26036	2 x 1		3.14	4.49
26040	84205	26041	2 x 1 1/4		3.02	4.83
26045	84210	26046	2 x 1 1/2		2.96	4.83

**MegaPress Reducer, Carbon Steel, P x P - Models 4815.2 / 6615.2**

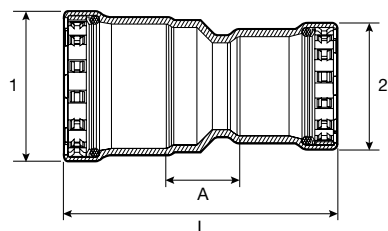

EPDM	Part No.		Size (in)		A (in)	L (in)
	FKM	HNBR	1	2		
25930		25931	3/4 x 1/2		1.20	3.43
25935		25936	1 x 1/2		1.37	3.79
25940		25941	1 x 3/4		1.24	3.74
25945		25946	1 1/4 x 3/4		1.40	4.37
25950		25951	1 1/4 x 1		1.23	4.39
25955		25956	1 1/2 x 1 1/4		1.21	4.90
25960		25961	2 x 1 1/4		1.45	5.27
25965		25966	2 x 1 1/2		1.43	5.26

**MegaPress Union, Carbon Steel, P x P - Model 4860 / 5960**

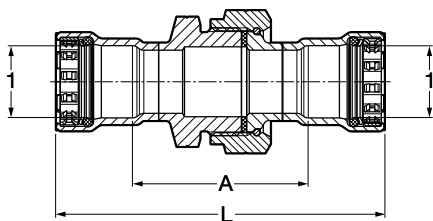

Part No.		Size (in)	A (in)	L (in)
<b>EPDM</b>	<b>FKM</b>	<b>1</b>		
25700	84815	1/2	2.35	4.50
25705	84820	3/4	2.67	4.99
25710	84825	1	2.65	5.34
25715	84830	1 1/4	2.84	6.48
25720	84835	1 1/2	2.89	6.63
25725	84840	2	3.92	7.89

**MegaPress Union, Carbon Steel, P x P - Model 6660**

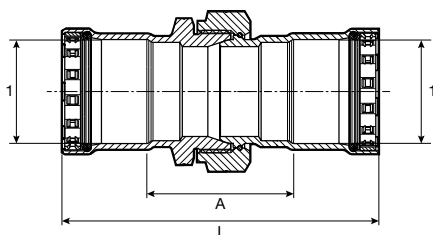

Part No.	Size (in)	A (in)	L (in)
<b>HNBR</b>	<b>1</b>		
25701	1/2	2.33	4.47
25706	3/4	2.67	4.98
25711	1	2.60	5.29
25716	1 1/4	2.85	6.49
25721	1 1/2	2.90	6.64
25726	2	3.41	7.35

**MegaPress Union, Carbon Steel, P x FPT - Model 4862**

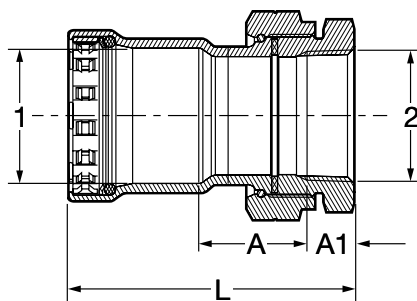

Part No.	Size (in)	A (in)	A1 (in)	L (in)
<b>EPDM</b>	<b>1 2</b>			
25650	1/2 x 1/2	1.25	0.54	2.85
25655	3/4 x 3/4	1.48	0.56	3.20
25660	1 x 1	1.37	0.66	3.38
25665	1 1/4 x 1 1/4	1.53	0.68	4.03
25670	1 1/2 x 1 1/2	1.55	0.68	4.10
25675	2 x 2	2.33	0.70	5.00

**MegaPress Union, Carbon Steel, P x FPT - Model 6662**

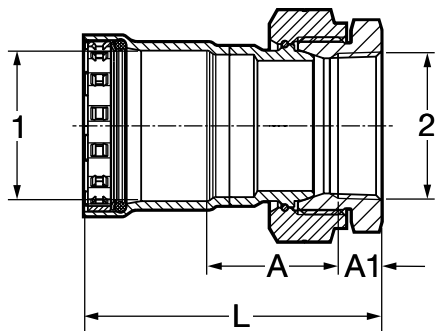

Part No.	Size (in)	A (in)	A1 (in)	L (in)
<b>HNBR</b>	<b>1 2</b>			
25651	1/2 x 1/2	1.38	0.54	2.98
25656	3/4 x 3/4	1.64	0.56	3.35
25661	1 x 1	1.62	0.66	3.63
25666	1 1/4 x 1 1/4	1.85	0.68	4.35
25671	1 1/2 x 1 1/2	1.80	0.68	4.35
25676	2 x 2	2.11	0.70	4.77



**MegaPress Flange, Carbon Steel, P x BP - Models 4859.5 / 5959.5 / 6659.5**

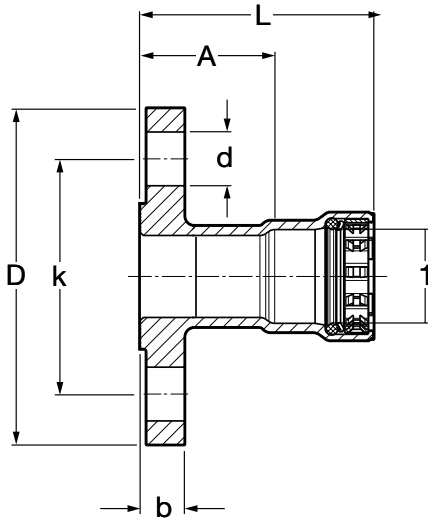

Part No.			Size (in)	A (in)	L (in)	b (in)	k (in)	D (in)	d (in)
EPDM	FKM	HNBR	1						
25760	84845	25761	1/2	1.51	2.58	0.46	2.36	3.54	0.63
25765	84850	25766	3/4	1.58	2.74	0.52	2.76	3.94	0.63
25770	84855	25771	1	1.75	3.10	0.58	3.11	4.33	0.63
25775	84860	25776	1 1/4	1.89	3.71	0.64	3.50	4.53	0.63
25780	84865	25781	1 1/2	2.06	3.93	0.70	3.86	4.92	0.63
25785	84870	25786	2	2.07	4.06	0.77	4.76	5.91	0.75

**MegaPress Cap, Carbon Steel, P x Cap - Models 4856 / 5956 / 6656**

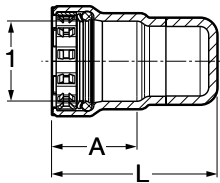

Part No.			Size (in)	A (in)	L (in)
EPDM	FKM	HNBR	1		
25730	84100	25731	1/2	1.07	2.14
25735	84105	25736	3/4	1.16	2.26
25740	84110	25741	1	1.35	2.43
25745	84115	25746	1 1/4	1.82	2.93
25750	84120	25751	1 1/2	1.87	3.02
25755	84125	25756	2	1.99	3.11

**MegaPress 3-Piece Ball Valve, Carbon Steel, P x P - Models 4875.8 / 5975.8**

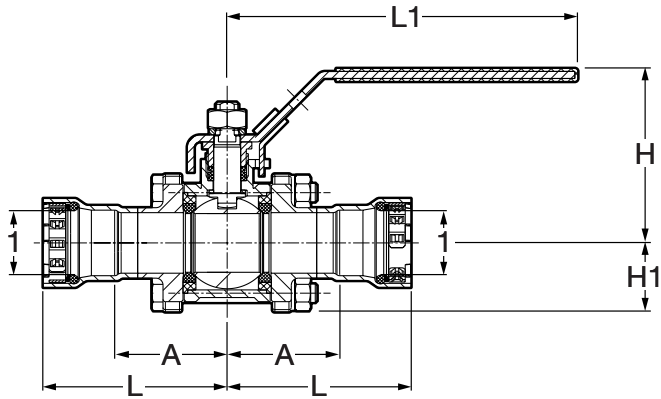

Part No.		Size (in)	A (in)	L (in)	L1 (in)	H (in)	H1 (in)
EPDM	FKM	1					
28500	86400	1/2	1.72	2.80	5.88	2.85	1.04
28501	86405	3/4	1.91	3.06	5.88	2.93	1.16
28502	86410	1	2.19	3.54	7.54	3.33	1.40
28503	86415	1 1/4	2.50	4.31	7.54	3.57	1.57
28504	86420	1 1/2	2.92	4.79	7.54	3.89	1.83
28505	86425	2	3.09	5.07	7.54	3.89	1.83

# Dimensional Documents

## MegaPress FKM 2½" to 4" Fittings

### Viega MegaPress XL 90° Elbow P x P - Models 4816XL / 6616XL

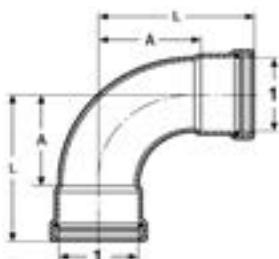

Part No.		Size (in)	A (in)	L (in)
MP XL	MPG XL	1		
26500	28600	2½	4.15	5.94
26505	28605	3	4.76	7.09
26510	28610	4	6.00	9.17

### Viega MegaPress XL 90° Street Elbow P x FTG - Models 4816.1XL / 6616.1XL

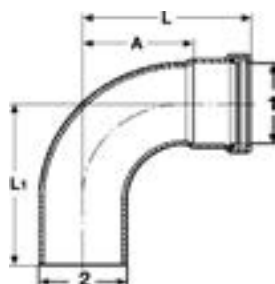

Part No.		Size (in)	A (in)	L (in)	L1 (in)
MP XL	MPG XL	1 2			
26515	28615	2½ x 2½	4.15	5.94	6.06
26520	28620	3 x 3	4.76	7.09	6.81
26525	28625	4 x 4	6.00	9.17	8.78

### Viega MegaPress XL 45° Elbow P x P - Models 4826XL / 6626XL

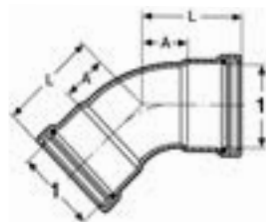

Part No.		Size (in)	A (in)	L (in)
MP XL	MPG XL	1		
26530	28630	2½	2.10	3.90
26535	28635	3	2.26	4.56
26540	28640	4	2.74	5.89

### Viega MegaPress XL 45° Street Elbow P x FTG - Models 4826.1XL / 6626.1XL

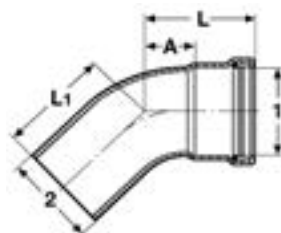

Part No.		Size (in)	A (in)	L (in)	L1 (in)
MP XL	MPG XL	1 2			
26545	28645	2½ x 2½	2.10	3.90	3.95
26550	28650	3 x 3	2.26	4.56	4.34
26555	28655	4 x 4	2.74	5.89	5.62

**Viega MegaPress XL Coupling with Stop P x P - Models 4815XL / 6615XL**

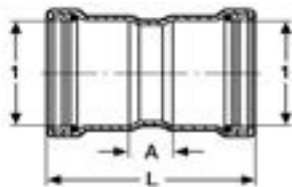

Part No.		Size (in)	A (in)	L (in)
MP XL	MPG XL	1		
26670	28770	2½	1.32	4.92
26675	28775	3	1.38	5.98
26680	28780	4	1.57	7.87

**Viega MegaPress XL Coupling No Stop P x P - Models 4815.5XL / 6615.5XL**

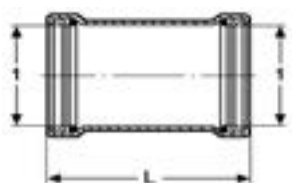

Part No.		Size (in)	L (in)
MP XL	MPG XL	1	
26685	28785	2½	4.92
26690	28790	3	5.98
26695	28795	4	7.91

**Viega MegaPress XL Reducer FTG x P - Models 4815.1XL / 6615.1XL**

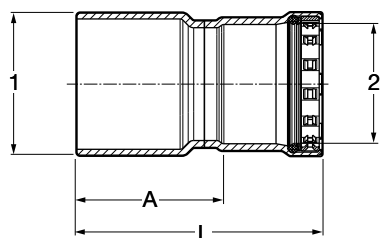

Part No.		Size (in)	A (in)	L (in)
MP XL	MPG XL	1 2		
26700	28800	2½ x 1	3.49	4.83
26705	28805	2½ x 1¼	3.37	5.19
26710	28810	2½ x 1½	3.30	5.17
26715	28815	2½ x 2	2.97	4.96
26720	28820	3 x 1¼	4.16	5.98
26725	28825	3 x 1½	4.08	5.95
26730	28830	3 x 2	3.76	5.75
26735	28835	3 x 2½	3.75	5.55
26740	28840	4 x 1½	5.60	7.47
26745	28845	4 x 2	5.28	7.27
26750	28850	4 x 2½	5.27	7.06
26755	28855	4 x 3	5.03	7.33

**Viega MegaPress XL Adapter P x MPT - Models 4811XL / 6611XL**

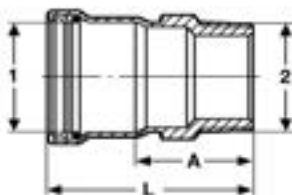

Part No.		Size (in)	A (in)	L (in)
MP XL	MPG XL	1 2		
26640	28740	2½ x 2½	2.75	4.55
26645	28745	3 x 3	2.89	5.20
26650	28750	4 x 4	3.03	6.21

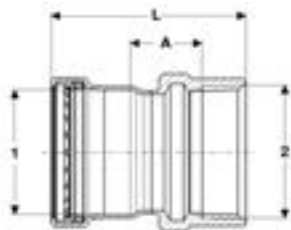
**Viega MegaPress XL Adapter P x FPT - Models 4812XL /6612XL**

Part No.		Size (in)		A (in)	L (in)
MP XL	MPG XL	1	2		
26655	28755	2½ x 2½		1.13	3.86
26660	28760	3 x 3		1.17	4.49
26665	28765	4 x 4		1.15	5.42

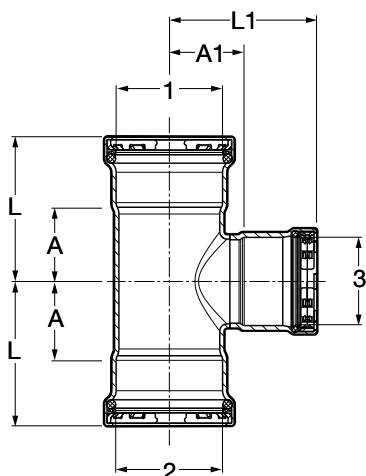
**Viega MegaPress XL Tee P x P x P - Models 4818XL / 6618XL**

Part No.		Size (in)			A (in)	A1 (in)	L (in)	L1 (in)
MP XL	MPG XL	1	2	3				
NA	28910	2½ x 2½ x 1			1.35	2.04	3.15	3.38
NA	28905	2½ x 2½ x 1¼			1.72	2.06	3.52	3.87
26575	28675	2½ x 2½ x 1½			1.72	2.08	3.52	3.95
26580	28680	2½ x 2½ x 2			2.16	2.05	3.96	4.04
26560	28660	2½ x 2½ x 2½			2.16	2.26	3.96	4.06
26595	28695	3 x 3 x 1¼			1.70	2.31	4.04	4.13
26590	28690	3 x 3 x 1½			1.80	2.33	4.13	4.20
26585	28685	3 x 3 x 2			2.11	2.30	4.41	4.29
26600	28700	3 x 3 x 2½			2.32	2.51	4.63	4.31
26565	28665	3 x 3 x 3			2.55	2.52	4.88	4.82
26605	28705	4 x 4 x 1½			1.86	2.90	5.04	4.77
26610	28710	4 x 4 x 2			2.18	2.87	5.35	4.86
26615	28715	4 x 4 x 2½			2.40	3.08	5.55	4.88
26620	28720	4 x 4 x 3			2.66	3.13	5.81	5.43
26570	28670	4 x 4 x 4			3.22	3.08	6.40	6.26

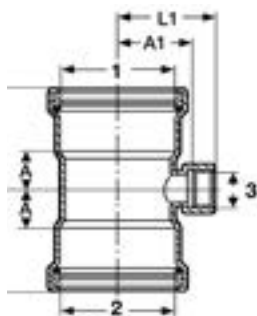
**Viega MegaPress XL Tee P x P x FPT - Models 4817.2XL / 6617.2XL**

Part No.		Size (in)			A (in)	A1 (in)	L (in)	L1 (in)
MP XL	MPG XL	1	2	3				
26625	28725	2½ x 2½ x ¾			1.35	2.00	3.15	2.55
26630	28730	3 x 3 x ¾			1.44	2.24	3.74	2.80
26635	28735	4 x 4 x ¾			1.55	2.76	4.72	3.31

**Viega MegaPress XL Cap P - Models 4856.1XL / 6656.1XL**

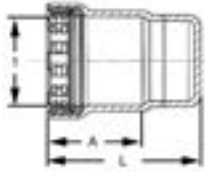

Part No.		Size (in)	A (in)	L (in)
MP XL	MPG XL	1		
26760	28860	2½	1.80	3.27
26765	28865	3	2.30	3.82
26770	28870	4	3.18	4.67

**Viega MegaPress XL Adapter Flange P - Models 4859XL / 6659XL**

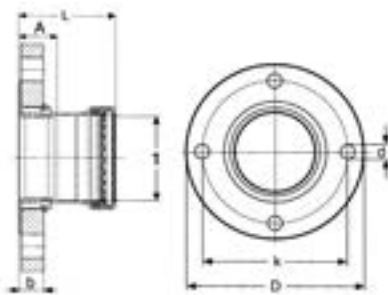

Part No.		Size (in)	A (in)	L (in)	b (in)	k (in)	D (in)	d (in)
MP XL	MPG XL	1						
26775	28875	2½	1.54	3.33	0.89	5.51	7.09	0.75
26780	28880	3	1.65	3.95	0.96	5.98	7.48	0.75

**Viega MegaPress XL Adapter Flange P - Models 4859XL / 6659XL**

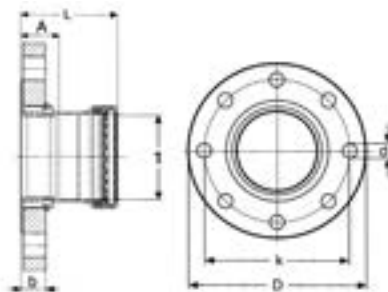

Part No.		Size (in)	A (in)	L (in)	b (in)	k (in)	D (in)	d (in)
MP XL	MPG XL	1						
26785	28885	4	1.63	4.80	0.96	7.52	9.06	0.75

## 5 Limited Warranty

### MegaPress

Subject to the conditions and limitations in this Limited Warranty, Viega LLC (Viega) warrants to end users, installers, and distribution houses that its Viega MegaPress metal press fittings (Viega Product) with application appropriate sealing element when properly installed in non-industrial and non-marine applications and under normal conditions of use shall be free from failure caused by manufacturing defects for a period of ten (10) years from date of installation in Viega MegaPress Approved Applications for fluids/water, oil and lubricant, and gases under Viega specified system operating conditions.

Under this Limited Warranty, you only have a right to a remedy if the failure or leak resulted from a manufacturing defect in the Viega Product and the failure or leak occurs during the warranty period. You do not have a remedy under this warranty and the warranty remedy does not apply if the failure or any resulting damage is caused by (1) components other than those manufactured or sold by Viega, such as black iron pipe; (2) not designing, installing, inspecting, testing, or maintaining the Viega Product in accordance with Viega's installation and product instructions in effect at the time of installation and other specifications and approvals applicable to the installation; (3) use of Viega Product under non recommended system operating conditions, improper handling and protection of the Viega Product prior to, during and after installation, inadequate freeze protection, or exposure to environmental conditions not recommended for the application; or (4) acts of nature, such as, but not limited to, earthquakes, fire, or weather damage. In the event of a leak or other failure of the Viega Product covered by this warranty, it is the responsibility of the end user to take appropriate measures to mitigate any damage, to include making timely repairs. Only if the warranty applies will Viega be responsible for the remedy under this warranty. The part or parts which you claim failed should be kept and Viega contacted by writing to the address below or telephoning 1-800-976-9819 within thirty (30) calendar

days after the leak or other failure and identifying yourself as having a warranty claim. You should be prepared to ship, at your expense, the product which you claim failed due to a manufacturing defect, document the date of installation, and the amount of the repair or replacement if performed by you. Within a reasonable time after receiving the product, Viega will investigate the reasons for the failure, which includes the right to inspect the product at a Viega location and reasonable access to the site of damage. Viega will notify you in writing as to the results of its review.

In the event that Viega determines that the failure or leak was the result of a manufacturing defect in the Viega Product covered by this warranty and this warranty applies, the EXCLUSIVE AND ONLY REMEDY under this warranty shall be the reimbursement for reasonable charges for repair or replacement of the Viega Product itself. VIEGA SHALL NOT BE LIABLE FOR ANY CONSEQUENTIAL OR OTHER DAMAGE (FOR EXAMPLE, ECONOMIC LOSS, WATER OR PROPERTY OR MOLD REMEDIATION) UNDER ANY LEGAL THEORY AND WHETHER ASSERTED BY DIRECT ACTION, FOR CONTRIBUTION OR INDEMNITY OR OTHERWISE. THE ABOVE WARRANTY IS IN LIEU OF ALL OTHER WARRANTIES, EXPRESS OR IMPLIED, INCLUDING, BUT NOT LIMITED TO, THE IMPLIED WARRANTIES OF MERCHANTABILITY AND FITNESS FOR A PARTICULAR PURPOSE OR ANY STATUTE OF LIMITATIONS RELATING TO SUCH WARRANTIES. Other than this Limited Warranty, Viega does not authorize any person or firm to create for it any other obligation or liability in connection with its products.

This Limited Warranty gives you specific legal rights and you also may have other rights which may vary from state to state. This warranty shall be interpreted and applied under the law of the state in which the product is installed and is intended as a COMMERCIAL WARRANTY.

# Limited Warranty

## Metal Systems for Industrial Applications

**Industrial applications are defined as non-residential and non-commercial applications not normally accessible to the general public, including manufacturing, mining, process or fabrication environments.**

Subject to the terms and conditions of this Limited Warranty, Viega LLC (Viega) warrants to end users, installers and distribution houses that its Viega metal press products (Viega product) when properly installed in industrial applications shall be free from failure caused by manufacturing defects for a period of two (2) years from date of installation.

Under this Limited Warranty, you only have a right to a remedy if the failure or leak resulted from a manufacturing defect in the Viega product and the failure or leak occurs during the warranty period. You do not have a remedy under this warranty and the warranty remedy does not apply if the failure or any resulting damage is caused by (1) components other than those sold by Viega; (2) not designing, installing, inspecting, testing, or maintaining the Viega product in accordance with Viega's installation and product instructions in effect at the time of installation and other specifications and approvals applicable to the installation; (3) improper handling and protection of the Viega product prior to, during and after installation, inadequate freeze protection, or exposure to environmental or operating conditions not recommended for the application; or (4) acts of nature, such as, but not limited to earthquakes, fire, or weather damage. Final approval as to use compatibility to a specific process or fluid application is the responsibility of the engineer of record or responsible design/facilities personnel and this Limited Warranty only applies to manufacturing defects in the Viega Product.

In the event of a leak or other failure in the Viega product covered by this warranty, it is the responsibility of the end user to take appropriate measures to diminish any damage, to include making timely repairs. Only if the warranty applies will Viega be responsible for the remedy under this warranty. The part or parts which you claim failed should be kept and Viega contacted by writing to the address below or telephoning 1-800-976-9819 within

thirty (30) calendar days after the leak or other failure and identifying yourself as having a warranty claim. You should be prepared to ship, at your expense, the product which you claim failed due to a manufacturing defect, document the date of installation, and the amount of the repair or replacement if performed by you. Within a reasonable time after receiving the product, Viega will investigate the reasons for the failure, which includes the right to inspect the product at a Viega location and reasonable access to the site of damage. Viega will notify you in writing as to the results of its review.

In the event that Viega determines that the failure or leak was the result of a manufacturing defect in the Viega Product covered by this warranty and to which this warranty applies, the EXCLUSIVE AND ONLY REMEDY under this warranty shall be the reimbursement for reasonable charges for repair or replacement of the Viega Product itself. VIEGA SHALL NOT BE LIABLE FOR CONSEQUENTIAL OR OTHER DAMAGE (FOR EXAMPLE, ECONOMIC LOSS, WATER OR PROPERTY OR MOLD REMEDIATION) UNDER ANY LEGAL THEORY AND WHETHER ASSERTED BY DIRECT ACTION, FOR CONTRIBUTION OR INDEMNITY OR OTHERWISE. THE ABOVE WARRANTY IS IN LIEU OF ALL OTHER WARRANTIES, EXPRESS OR IMPLIED, INCLUDING, BUT NOT LIMITED TO, THE IMPLIED WARRANTIES OR ANY STATUTE OF LIMITATIONS RELATING TO SUCH WARRANTIES. Other than this Limited Warranty, Viega does not authorize any person or firm to create for it any other obligation or liability in connection with its products. This Limited Warranty gives you specific legal rights and you also may have other rights which may vary from state to state. This warranty shall be interpreted and applied under the law of the state in which the product is installed and is intended as a Commercial Warranty.

**V Viega LLC**  
585 Interlocken Blvd.  
Broomfield, CO 80021

Phone (800) 976-9819  
[www.viega.us](http://www.viega.us)

SM-MP 0120 MegaPress FKM Fittings

