

NIBCO®

AHEAD OF THE FLOW®

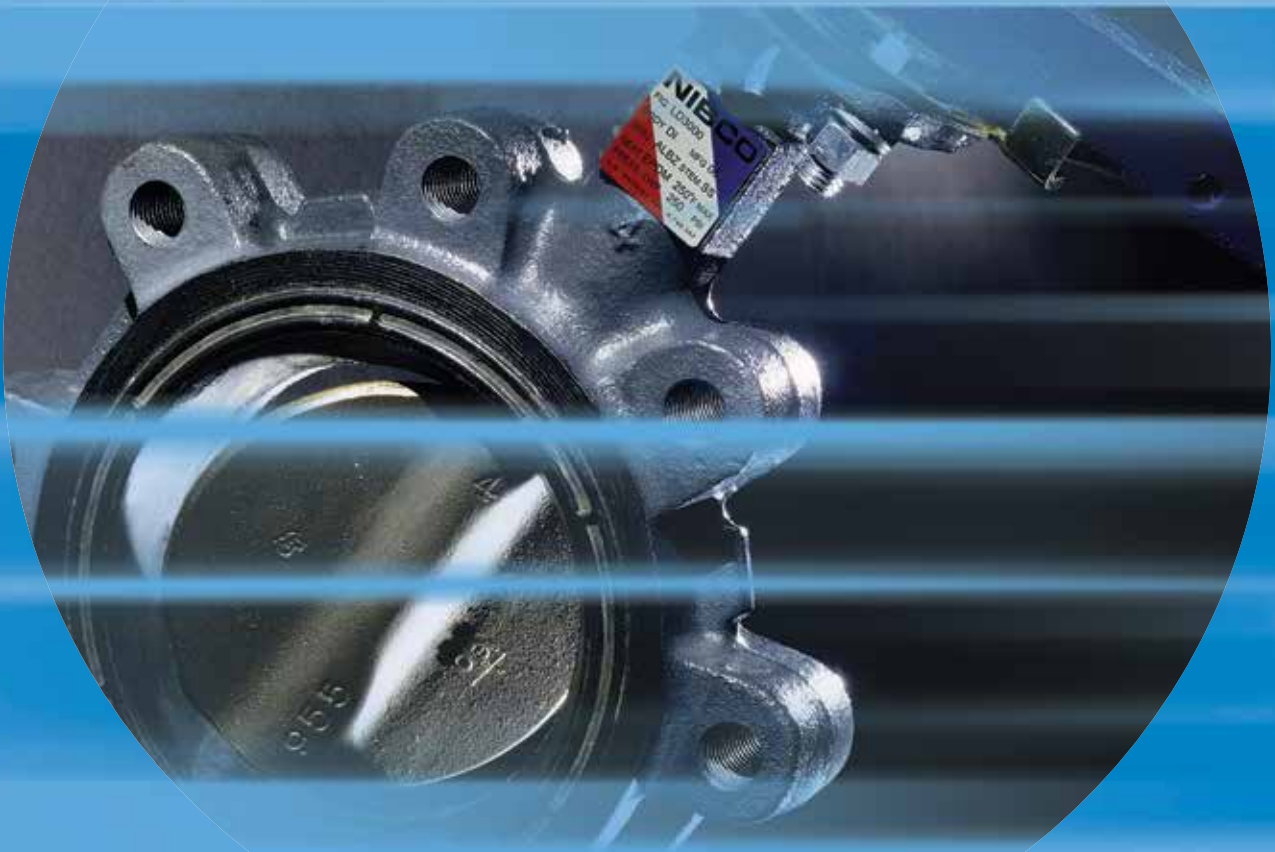

Butterfly Valves

Business-to-Business Solutions

Look to NIBCO for technology leadership.

The velocity with which e-business evolves demands that new products and services be continuously developed and introduced to keep our customers at the center of our business efforts. NIBCO provides an entire suite of business-to-business solutions that is changing the way we interact with customers.



[NIBCOpartner.comSM](http://NIBCOpartner.com) is an exclusive set of secure web applications that allow quick access to customer-specific information and online order processing. This self-service approach gives you 24/7 access to your order status putting you in total control of your business.

Real time information includes:

- Online order entry
- Viewable invoices & reports
- Inventory availability
- Current price checks
- Order status
- Online library of price sheets, catalogs & submittals



Electronic Data Interchange (EDI) makes it possible to trade business documents at the speed of light. This technology cuts the cost of each transaction by eliminating the manual labor and paperwork involved in traditional order taking. This amounts to cost-savings, increased accuracy and better use of resources.

With EDI, you can trade:

- Purchase orders
- PO Acknowledgements
- Invoices
- Product activity data
- Advanced ship notices
- Remittance advice



Vendor Managed Inventory (VMI), a sophisticated service for automated inventory management, reduces your overhead by transferring inventory management, order entry and forecasting to NIBCO. This is an on-going, interactive partnership with NIBCO.

Through automation, VMI brings results:

- Improves customer service
- Optimum inventory efficiencies
- Better forecasting
- Cuts transaction costs
- Peace of mind
- Relief from day-to-day management



General Index

Butterfly Valves



Visit our website for the most current information.

WARRANTY	4	ENGINEERING DATA INDEX	46
BUTTERFLY VALVES	5-35	Specifications	47
HIGH PERFORMANCE BUTTERFLY VALVE	36-42	Flow Data	48-49
OPTIONS AND		Properties of Materials	50-53
ACCESSORIES INDEX	43-45	Technical Information	54-60
		Actuation Data Sheet	61
		FIGURE NUMBER COMPARISONS	62

Key to Butterfly Valve Figure Number System*

L	D	-	2	0	0	0	-	0
Body Type	Body Material	Pressure Rating	Seat Material	Disc Material	Stem	Stem & Bushing Combinations Upper & Lower	Collar	Operating Mechanism
L-Lug	D-Ductile Iron	L-Actuated	0-EPDM	0-Aluminum Bronze	0-416SS	Copper Alloy	Brass	0-Bare Stem
W-Wafer	C-Cast Iron	1-150 psi	1-Buna-N (Nitrile)	1-Ductile Iron ¹	1-416SS	316SS	Brass	1-Infinite Position
G-Grooved		2-200 psi	2-Fluoroelastomer	2-CF8M	2-17-4PH ³	316SS ³	316SS	Plate and Lock
F-Flanged		3-250 psi	5-UL/FM	6-EPDM Coated	5-416SS	PTFE/Bronze	-	3-Lever Lock (std)
		4-300 psi	7-Polyamide	Ductile Iron ²	7-416SS	PTFE	-	5-Gear
		5-285 psi		7-Buna-N Coated	8-316SS			
		6-350 psi		Brass or Ductile Iron ²	9-17-4PH			
		7-232 psi		8-Nylon Coated				
				Ductile Iron				

*This key is a guide only, it is not intended to imply that all combinations can or will be produced.

¹ Electro nickel plated.

² Grooved and flanged end only.

³ Lug style 14" and larger are 316SS stem with bronze bushings.

Key to N200 Butterfly Valves

Series	Body Style	Seat Material	Disc Material	Operator
N200 = 2"-12"	1 = Wafer 2 = Lug	3 = EPDM 4 = Buna	5 = Aluminum Bronze 6 = Ductile Iron 8 = Nylon Coated Ductile Iron	LH = Lever GO = Gear

High Performance Butterfly Valves Figure Number Key*

L	CS	-	6	8	2	2	-	0
Body Type	Body Material	Pressure Class	Seat Material	Disc Material	Stem	Stem & Bushing Combinations Upper & Lower	Operating Mechanism	
L-Lug	CS-Carbon	6-150	8-RPTFE	2-316 Stainless Steel	2-17-4PH	PTFE Coated	0-Bare Stem	
W-Wafer	Steel	7-300				Alloy 304SS	1-Infinite Position	
							Throttling Plate (option)	
							3-Lever Handle (std)	
							5-Gear Operated	

*This key is a guide only. It is not intended to infer that all combinations can or will be produced.

Warranty



NIBCO INC. 125% LIMITED WARRANTY

Applicable to NIBCO INC. Pressure Rated Metal Valves

NIBCO INC. warrants each NIBCO pressure rated metal valve to be free from defects in materials and workmanship under normal use and service for a period of five (5) years from date put into service.

In the event any defect occurs which the owner believes is covered by this warranty, the owner should immediately contact NIBCO Technical Services, either in writing or by telephone at 1.888.446.4226 or 1.574.295.3000. The owner will be instructed to return said product, at the owner's expense, to NIBCO INC., or an authorized representative for inspection. In the event said inspection discloses to the satisfaction of NIBCO INC. that said valve is defective, it will be replaced at the expense of NIBCO INC.. Replacements shall be shipped free of charge to the owner. In the event of the replacement of any valve, NIBCO INC. shall further pay the owner the greater of twenty-five (25%) percent of the price of the valve according to the published suggested list price schedule of NIBCO INC. in effect at the time of purchase, or ten (\$10.00) dollars, to apply on the cost of the installation of said replacement valve.

TO THE EXTENT PERMITTED BY LAW, THIS WARRANTY SPECIFICALLY EXCLUDES INCIDENTAL AND CONSEQUENTIAL DAMAGES OF EVERY TYPE AND DESCRIPTION RESULTING FROM ANY CLAIMED DEFECT IN MATERIAL OR WORKMANSHIP, INCLUDING BUT NOT LIMITED TO, PERSONAL INJURIES AND PROPERTY DAMAGES.

Some states or countries do not allow the exclusion or limitation of incidental or consequential damages so these limitations may not apply to you.

TO THE EXTENT PERMITTED BY LAW, IMPLIED WARRANTIES OF MERCHANTABILITY AND FITNESS FOR A PARTICULAR PURPOSE ARE LIMITED IN DURATION.

This warranty gives you specific legal rights, and you may also have other rights which vary from state to state and country to country.

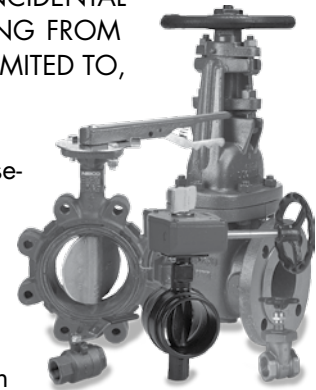

Butterfly Valves

Factors to Consider When Choosing Butterfly Valves

Operating Life	Butterfly valves can provide many maintenance free cycles and still accommodate "bubble tight" shut off.
Pressure Drop	Energy costs go up with excessive pressure drop. The valve or valves are but one factor in a piping system that contribute to pressure drop. Of equal concern are these factors: <ul style="list-style-type: none">• Flow area of piping.• Friction loss against pipe walls.• Change of flow direction via fittings. Butterfly valves have flow characteristics three times better than globe valves and approximately 75% of an equivalent size gate valve.
Versatility	Butterfly valves can be used for on/off service and throttling/balancing. They are superior in "versatility" as compared to a gate or globe valve. Butterfly valves have a wider range of chemical resistance due to the trim options and choice of elastomeric liners.
Weight	Installation dollars saved with lightweight butterfly valves as compared to heavyweight cast iron valves; i.e. a 10" butterfly may weigh 55 pounds, whereas a 10" iron gate may weigh 490 pounds. This can be an important savings when it is calculated over an entire system. The heavier the system, the stronger the pipe hangers, and the more expensive they become. So by considering the weight of a valve one can also reduce piping system costs.
Physical Size	Butterfly valves take up approximately 1/6 the space of a gate valve. Every cubic foot of a building costs money. I.E.: 10" butterfly is about 21" high 10" iron gate is about 43" high
Bubble Tight Shut-Off	Gate and globe (metal to metal) seats cannot provide bubble tight shut-off. Resilient seated butterfly valves are bubble tight by design.
Ease of Operation	Butterfly valves offer 1/4 turn (90°) open to close. Gates and globes require multiple turns to open and close. Ease of opening or closing means that butterfly valves can employ less expensive operators.
Cost	A butterfly valve is generally 40% the cost of an iron gate valve, not only low initial cost but low installation costs also.
Maintenance	Properly installed butterfly valves are virtually self cleaning and are less susceptible to failure due to trash material in the line.

2000/3000/5000 Series Butterfly Valves

* **Threaded Collar Bushing** for positive stem retention (blow-out proof)

Body and Stem O-ring Seals of EPDM, Buna-N or Fluorocarbon.

Extended Neck for insulation up to 2".

Molded-in Liner fully supported by valve body at flange seals. Eliminates leakage between body and liner as in cartridge or boot type liners. Provides dead-end service without the need for a flange on the downstream side.

* **Do not remove collar bushing with valve under pressure.**



High-Strength Stem materials with one-piece thru-disc design.

Upper and Lower Bushings are standard for smooth valve operation.

Streamlined Spherical Disc with high flow capacity.

Internal Stem/Disc Drive eliminates the need for pins or bolts which create additional leak paths, turbulence in the waterway and/or flow reduction.

Ductile Iron Body more durable than cast iron (reduces breakage).

"Blind-Hole" lower bushing prevents leakage.

A High-Pressure Resilient-Seated Butterfly Valve Featuring:

- Pressure rating to 250 psi, 285 psi for 5000 Series, vacuum to 28" Mercury
- Wide choice of materials to suit customer's application
- Bubble-tight shutoff at full pressure rating
- 200/232/250 bi-directional dead end service rating without a downstream flange required

Operation

Bare shaft, lever-lock flow control handle, worm gear operator, electric and pneumatic actuators

Body Styles

Tapped full lug or wafer

Butterfly Valves Illustrated Index







Visit www.nibco.com for on-line listing of information contained in this catalog.

<p>Ductile Iron Body 200 PSI Wafer Style Butterfly Valve</p>  <p>WD2000 Series Sizes 2" thru 12" Molded-in Liner Aluminum Bronze Disc Pages 9 - 10</p>	<p>Ductile Iron Body 200 PSI Lug Style Butterfly Valve</p>  <p>LD2000 Series Sizes 2" thru 12" Molded-In Liner Aluminum Bronze Disc Pages 9 - 10</p>	<p>Ductile Iron Body 250 PSI Wafer Style Butterfly Valve</p>  <p>WD3000 Series Sizes 2" thru 12" Molded-in Liner Ductile Iron/SS Disc/Aluminum Bronze Pages 11 - 15</p>	<p>Ductile Iron Body 250 PSI Lug Style Butterfly Valve</p>  <p>LD3000 Series Sizes 2" thru 12" Molded-in Liner Ductile Iron/SS Disc/Aluminum Bronze Pages 11 - 15</p>
<p>UL Listed, FMRC Approved Ductile Iron Body Gear Operated with Flag Indicator</p>  <p>LD3510-8/WD3510-8 Sizes 2" thru 12" Ductile Iron Body Page 16</p>	<p>UL Listed, FM Approved Ductile Iron Body Gear Operated designed for Closed Position Monitoring</p>  <p>LD3510-C-8/WD3510-C-8 Sizes 2" thru 8" Ductile Iron Body Page 17</p>	<p>Ductile Iron Body 285 PSI Wafer/Lug Style Butterfly Valve</p>  <p>LD5022/WD5022 Sizes 2" thru 12" Molded-in Liner Stainless Steel Disc Page 18</p>	<p>Ductile Iron Body 150 PSI Lug Style Butterfly Valve</p>  <p>LD1000 Series Sizes 14" thru 48" Cartridge Liner Aluminum Bronze, DI or SS Disc Pages 19 - 22</p>
<p>Ductile Iron Body 200 PSI Lug Style Butterfly Valve</p>  <p>LD2000 Series Sizes 14" thru 24" Cartridge Liner Aluminum Bronze, DI or SS Disc Pages 19 - 22</p>	<p>Cast Iron Body 200 PSI Wafer Style Butterfly Valve</p>  <p>WC2000 Series Sizes 2" thru 12" Molded-in Liner Aluminum Bronze Disc Pages 23 - 24</p>	<p>Cast Iron Body 200 PSI Lug Style Butterfly Valve</p>  <p>LC2000 Series Sizes 2" thru 12" Molded-In Liner Aluminum Bronze Disc Pages 23 - 24</p>	<p>Cast Iron Body 200 PSI Wafer/Lug Style Butterfly Valve</p>  <p>N200 Sizes 2" thru 12" Pages 25 - 26</p>

Butterfly Valves

Illustrated Index

Visit www.nibco.com for on-line listing of information contained in this catalog.

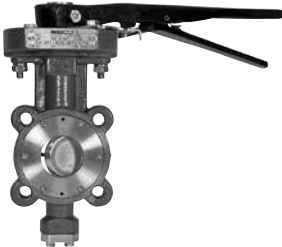
<p>Ductile Iron Body Polyamide Coating 300 PSI Grooved End Butterfly Valve</p>  <p>GD4765/4775 Sizes 2" thru 12" Elastomer Coated Disc Page 28</p>	<p>Ductile Iron Body Polyamide Coating 300 PSI Grooved End Butterfly Valve NSF/ANSI 61 NSF/ANSI 372</p>  <p>GD4765N Sizes 2" thru 12" Elastomer Coated Disc Page 29</p>	<p>UL Listed, FM Approved Polyamide Coated Ductile Iron Body Gear Operator with Flag 300 PSI W.W.P.</p>  <p>GD1765-8N/GD4765-8N Grooved Mechanical Type Sizes 2½" thru 10" Page 30</p>
<p>UL Listed, FM Approved Polyamide Coated Ductile Iron Body Gear Operator designed for Closed Position Monitoring 300 PSI W.W.P.</p>  <p>GD4765-C-8N Grooved Mechanical Type Sizes 2½" thru 8" Page 31</p>	<p>UL Listed Nylon Coated Ductile Iron Body Gear Operator with Flag 350 lb. WWP</p>  <p>GD6765-8N Grooved Mechanical Style Sizes 2½", 3", 4", 6", 8", 10" Page 32</p>	<p>CI or DI Body 200/285 PSI Flanged Butterfly Valve</p>  <p>FC2000/FD5000 Series Sizes 2" thru 12" Elastomer Coated Disc Pages 33 - 35</p>
<p>Carbon Steel 150/300 Class High Performance Butterfly Valve</p>  <p>LCS6822/LCS7822 Series Sizes 2 ½" thru 30" SS Disc Pages 36 - 42</p>		

200 PSI Butterfly Valves

ductile iron body • extended neck • geometric drive
molded-in seat liner • lug and wafer style

Sizes 2" through 12"

Install between Std. ASME Class 125/150 flanges.
Lug Style 200 PSI bi-directional dead end service rating without a downstream flange required.

DESIGNED TO MEET MSS SP-67 STANDARD •
U.S. COAST GUARD "CATEGORY A" • CERTIFIED LEAD-FREE* BY
TRUESDAIL LABS TO NSF/ANSI 61-8 COMMERCIAL HOT 180°F
(INCLUDES ANNEX F AND G) AND NSF/ANSI-372



NSF/ANSI 61
NSF/ANSI 372



WD 2000
Wafer Style
EPDM Liner
and Aluminum
Bronze Disc



LD 2000
Lug Style
EPDM Liner
and Aluminum
Bronze Disc

MATERIAL LIST

PART	SPECIFICATION
1. Stem	Stainless Steel ASTM A582 Type 416
2. Collar Bushing	Brass ASTM B16
3. Stem Seal	EPDM Rubber
4. Body Seal	EPDM Rubber
5. Nameplate	Aluminum
6. Upper Bushing	Copper CDA 122
7. Liner	EPDM Rubber
8. Disc	Alum. Brz. ASTM B148 Alloy 955
9. Lower Bushing	Copper CDA 122
10. Body Wafer	Ductile Iron ASTM A536
11. Body Lug	Ductile Iron ASTM A536

DIMENSIONS — WEIGHTS

Size	A		B		C		D		E		F		G		Metal		Rubber		J		N	
In. mm.	In. mm.		In. mm.		In. mm.		In. mm.		In. mm.		In. mm.		Flat		H		I		Square		Dia.	
2	50	2.53	4.00	1.25	5.38	2.88	.38	.312	1.688	1.812	1.938	3.25	.500									
2½	65	2.90	4.69	1.25	5.88	3.27	.38	.370	1.812	1.938	3.25	.562										
3	80	3.15	5.12	1.25	6.12	3.40	.38	.370	1.812	1.938	3.25	.562										
4	100	4.09	6.12	1.25	6.88	4.00	.38	.403	2.062	2.188	3.25	.625										
5	125	5.13	7.25	1.25	7.38	4.75	.38	.496	2.188	2.312	3.25	.750										
6	150	6.13	8.25	1.25	8.00	5.29	.38	.496	2.188	2.312	3.25	.750										
8	200	8.13	10.41	1.25	9.25	6.50	.50	.560	2.375	2.500	3.25	.875										
10	250	10.13	12.52	1.25	10.50	8.00	.50	.686	2.688	2.812	4.75	1.125										
12	300	12.13	15.00	1.25	12.00	9.25	.50	.748	3.000	3.125	4.75	1.250										

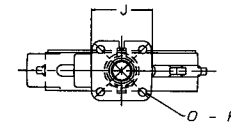
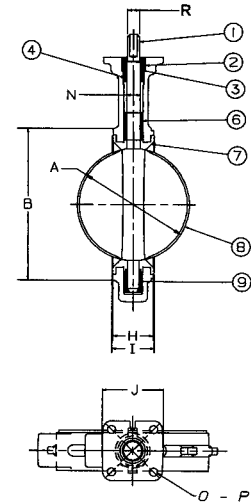

Capscrew/Stud Data

Size	O	P	R	K	L	Wafer Length	Lug Length	M	Lug Weight		Wafer Weight	
In. mm.	B.C.	Dia.	Dia.	No.	Dia.			B.C.	Lbs.	Kg.	Lbs.	Kg.
2	50	3.25	.437	.437	4	5/8-11unc	Refer to butterfly valve technical information for bolt lengths	4 3/4	7	3.2	5.5	2.5
2½	65	3.25	.437	.500	4	5/8-11unc		5 1/2	9	4.1	7.5	3.4
3	80	3.25	.437	.500	4	5/8-11unc		6	9.5	4.3	8	3.6
4	100	3.25	.437	.562	8	5/8-11unc		7 1/2	15	6.8	11	5.0
5	125	3.25	.437	.656	8	3/4-10unc		8 1/2	21	9.5	15	6.8
6	150	3.25	.437	.656	8	3/4-10unc		9 1/2	24	10.9	18	8.2
8	200	3.25	.437	.781	8	3/4-10unc		11 3/4	34	15.4	28	12.7
10	250	5.00	.562	1.000	12	7/8-9unc		14 1/4	62	28.1	45.5	20.7
12	300	5.00	.562	1.062	12	7/8-9unc		17	90	40.9	70	31.8

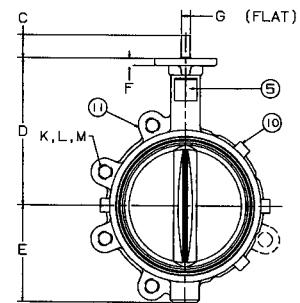

NOT RECOMMENDED
FOR STEAM SERVICE

For actuated service where a lower torque is required use NIBCO Fig. No. WDLXXX-0 or LDLXXX-0 series, sizes 2" thru 12" only. Maximum pressure rating of 100 PSI for wet application and 50 PSI for dry application.

*Weighted average lead content ≤ 0.25%

200 PSI Butterfly Valves

ductile iron body • extended neck • geometric drive
molded-in seat liner • lug and wafer style

Sizes 2" through 12"

Install between Std. ASME Class 125/150 flanges.
Lug Style 200 PSI bi-directional dead end service rating without a downstream flange required.

DESIGNED TO MEET MSS SP-67 STANDARD
U.S. COAST GUARD "CATEGORY A"

MATERIAL LIST

PART	SPECIFICATION
1. Stem	Stainless Steel ASTM A582 Type 416
2. Collar Bushing	Brass ASTM B16
3. Stem Seal	Buna-N Rubber Nitrile
4. Body Seal	Buna-N Rubber Nitrile
5. Nameplate	Aluminum
6. Upper Bushing	Copper CDA 122
7. Liner	Buna-N Rubber Nitrile
8. Disc	Alum. Brz. ASTM B148 Alloy 954/955
9. Lower Bushing	Copper CDA 122
10. Body Wafer	Ductile Iron ASTM A536
11. Body Lug	Ductile Iron ASTM A536

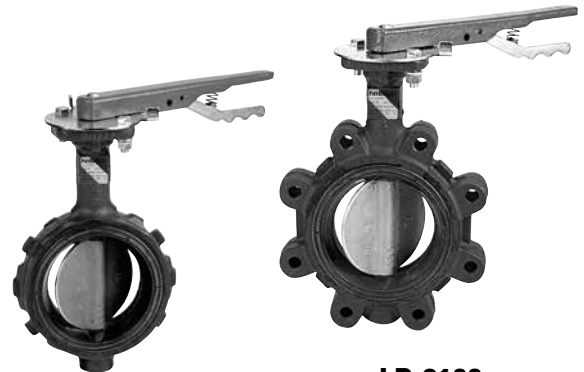

WD 2100
Wafer Style
Buna-N Liner
and Aluminum
Bronze Disc

LD 2100
Lug Style
Buna-N Liner
and Aluminum
Bronze Disc

DIMENSIONS — WEIGHTS

Size								G	Metal		J	N
In.	mm.	A	B	C	D	E	Flat	H	I	Square	Dia.	
2	50	2.53	4.00	1.25	5.38	2.88	.38	.312	1.688	1.812	3.25	.500
2 1/2	65	2.90	4.69	1.25	5.88	3.27	.38	.370	1.812	1.938	3.25	.562
3	80	3.15	5.12	1.25	6.12	3.40	.38	.370	1.812	1.938	3.25	.562
4	100	4.09	6.12	1.25	6.88	4.00	.38	.403	2.062	2.188	3.25	.625
5	125	5.13	7.25	1.25	7.38	4.75	.38	.496	2.188	2.312	3.25	.750
6	150	6.13	8.25	1.25	8.00	5.29	.38	.496	2.188	2.312	3.25	.750
8	200	8.13	10.41	1.25	9.25	6.50	.50	.560	2.375	2.500	3.25	.875
10	250	10.13	12.52	1.25	10.50	8.00	.50	.686	2.688	2.812	4.75	1.125
12	300	12.13	15.00	1.25	12.00	9.25	.50	.748	3.000	3.125	4.75	1.250

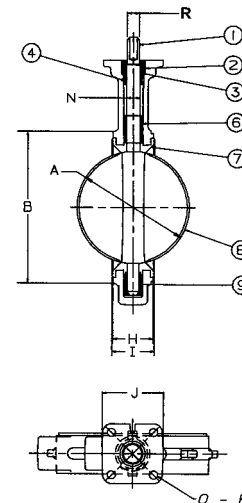

Capscrew/Stud Data

Size	O	P	R	K	L	Wafer	Lug	M	Lug		Wafer	
									Weight	Weight	Lbs.	Kg.
In. mm.	B.C.	Dia.	Dia.	No.	Dia.	Length	Length	B.C.				
2	50	3.25	.437	.437	4	5/8-11unc		4 3/4	7	3.2	5.5	2.5
2 1/2	65	3.25	.437	.500	4	5/8-11unc		5 1/2	9	4.1	7.5	3.4
3	80	3.25	.437	.500	4	5/8-11unc		6	9.5	4.3	8	3.6
4	100	3.25	.437	.562	8	5/8-11unc		7 1/2	15	6.8	11	5.0
5	125	3.25	.437	.656	8	3/4-10unc		8 1/2	21	9.5	15	6.8
6	150	3.25	.437	.656	8	3/4-10unc		9 1/2	24	10.9	18	8.2
8	200	3.25	.437	.781	8	3/4-10unc		11 3/4	34	15.4	28	12.7
10	250	5.00	.562	1.000	12	7/8-9unc		14 1/4	62	28.1	45.5	20.7
12	300	5.00	.562	1.062	12	7/8-9unc		17	90	40.9	70	31.8

Refer to butterfly valve technical information for bolt lengths

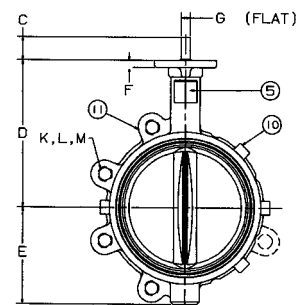

NOT RECOMMENDED
FOR STEAM SERVICE



NSF/ANSI 61
NSF/ANSI 372

250 PSI Butterfly Valves

ductile iron body • extended neck • geometric drive • molded-in seat liner • lug and wafer style

Sizes 2" through 12"

Install between Std. ASME Class 125/150 flanges.

Lug Style 232 PSI bi-directional dead end service rating without a downstream flange required.

DESIGNED TO MEET MSS SP-67 STANDARD •
U.S. COAST GUARD "CATEGORY A" • CERTIFIED LEAD-FREE* BY
TRUESDAIL LABS TO NSF/ANSI 61-8 COMMERCIAL HOT 180°F
(INCLUDES ANNEX F AND G) AND NSF/ANSI-372

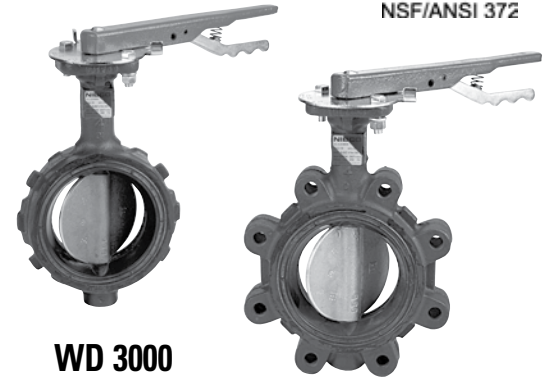

WD 3000

Wafer Style
EPDM Liner
and Aluminum
Bronze Disc

LD 3000

Lug Style
EPDM Liner
and Aluminum
Bronze Disc

MATERIAL LIST

PART	SPECIFICATION
1. Stem	Stainless Steel ASTM A582 Type 416
2. Collar Bushing	Brass ASTM B16
3. Stem Seal	EPDM Rubber
4. Body Seal	EPDM Rubber
5. Nameplate	Aluminum
6. Upper Bushing	Copper CDA 122
7. Liner	EPDM Rubber
8. Disc	Alum. Brz. ASTM B148 Alloy 954/955
9. Lower Bushing	Copper CDA 122
10. Body Wafer	Ductile Iron ASTM A536
11. Body Lug	Ductile Iron ASTM A536

DIMENSIONS — WEIGHTS

Size	DIMENSIONS											
	In.	mm.	A	B	C	D	E	F	G Flat	Metal H	Rubber I	J Square
2	50	2.53	4.00	1.25	5.38	2.88	.38	.312	1.688	1.812	3.25	.500
2 1/2	65	2.90	4.69	1.25	5.88	3.27	.38	.370	1.812	1.938	3.25	.562
3	80	3.15	5.12	1.25	6.12	3.40	.38	.370	1.812	1.938	3.25	.562
4	100	4.09	6.12	1.25	6.88	4.00	.38	.403	2.062	2.188	3.25	.625
5	125	5.13	7.25	1.25	7.38	4.75	.38	.496	2.188	2.312	3.25	.750
6	150	6.13	8.25	1.25	8.00	5.29	.38	.496	2.188	2.312	3.25	.750
8	200	8.13	10.41	1.25	9.25	6.50	.50	.560	2.375	2.500	3.25	.875
10	250	10.13	12.52	1.25	10.50	8.00	.50	.686	2.688	2.812	4.75	1.125
12	300	12.13	15.00	1.25	12.00	9.25	.50	.748	3.000	3.125	4.75	1.250

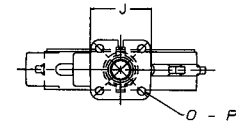
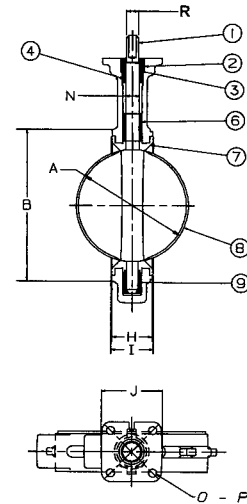

Size	Capscrew/Stud Data						Wafer Lug Length	Lug Length	M B.C.	Lug Weight		Wafer Weight	
	In.	mm.	O B.C.	P Dia.	R Dia.	K L No. Dia.				Lbs.	Kg.	Lbs.	Kg.
2	50	3.25	.437	.437	4	5/8-11unc	Refer to butterfly valve technical information for bolt lengths	4 3/4	7	3.2	5.5	2.5	
2 1/2	65	3.25	.437	.500	4	5/8-11unc		5 1/2	9	4.1	7.5	3.4	
3	80	3.25	.437	.500	4	5/8-11unc		6	9.5	4.3	8	3.6	
4	100	3.25	.437	.562	8	5/8-11unc		7 1/2	15	6.8	11	5.0	
5	125	3.25	.437	.656	8	3/4-10unc		8 1/2	21	9.5	15	6.8	
6	150	3.25	.437	.656	8	3/4-10unc		9 1/2	24	10.9	18	8.2	
8	200	3.25	.437	.781	8	3/4-10unc		11 3/4	34	15.4	28	12.7	
10	250	5.00	.562	1.000	12	7/8-9unc		14 1/4	62	28.1	45.5	20.7	
12	300	5.00	.562	1.062	12	7/8-9unc		17	90	40.9	70	31.8	

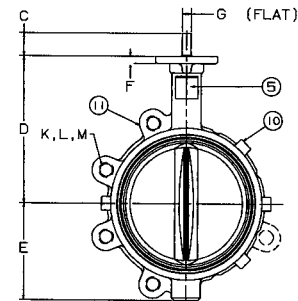

NOT RECOMMENDED FOR STEAM SERVICE

250 PSI Butterfly Valves

ductile iron body • extended neck • geometric drive
molded-in seat liner • lug and wafer style

Sizes 2" through 12"

Install between Std. ASME Class 125/150 flanges.
Lug Style 250 PSI bi-directional dead end service rating without a downstream flange required.

DESIGNED TO MEET MSS SP-67 STANDARD
U.S. COAST GUARD "CATEGORY A"

MATERIAL LIST

PART	SPECIFICATION
1. Stem	Stainless Steel ASTM A582 Type 416
2. Collar Bushing	Brass ASTM B16
3. Stem Seal	EPDM Rubber
4. Body Seal	EPDM Rubber
5. Nameplate	Aluminum
6. Upper Bushing	Copper CDA 122
7. Liner	EPDM Rubber
8. Disc	Ductile Iron ASTM A395 (plated)
9. Lower Bushing	Copper CDA 122
10. Body Wafer	Ductile Iron ASTM A536
11. Body Lug	Ductile Iron ASTM A536



WD 3010
Wafer Style
EPDM Liner
and Ductile Disc

LD 3010
Lug Style
EPDM Liner
and Ductile Disc

DIMENSIONS — WEIGHTS

Size		DIMENSIONS								Metal		Rubber		J		N	
In.	Mm.	A	B	C	D	E	F	G Flat	H	I	Square	Dia.					
2	50	2.53	4.00	1.25	5.38	2.88	.38	.312	1.688	1.812	3.25	.500					
2 1/2	65	2.90	4.69	1.25	5.88	3.27	.38	.370	1.812	1.938	3.25	.562					
3	80	3.15	5.12	1.25	6.12	3.40	.38	.370	1.812	1.938	3.25	.562					
4	100	4.09	6.12	1.25	6.88	4.00	.38	.403	2.062	2.188	3.25	.625					
5	125	5.13	7.25	1.25	7.38	4.75	.38	.496	2.188	2.312	3.25	.750					
6	150	6.13	8.25	1.25	8.00	5.29	.38	.496	2.188	2.312	3.25	.750					
8	200	8.13	10.41	1.25	9.25	6.50	.50	.560	2.375	2.500	3.25	.875					
10	250	10.13	12.52	1.25	10.50	8.00	.50	.686	2.688	2.812	4.75	1.125					
12	300	12.13	15.00	1.25	12.00	9.25	.50	.748	3.000	3.125	4.75	1.250					

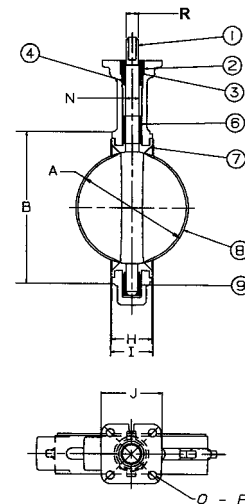

Capscrew/Stud Data

Size	Capscrew/Stud Data						Lug Length	M B.C.	Lug Weight		Wafer Weight	
	O B.C.	P Dia.	R Dia.	K No.	L Dia.	Wafer Length			Lbs.	Kg.	Lbs.	Kg.
2	50	3.25	.437	.437	4	5/8-11unc	4 3/4	7	3.2	5.5	2.5	
2 1/2	65	3.25	.437	.500	4	5/8-11unc	5 1/2	9	4.1	7.5	3.4	
3	80	3.25	.437	.500	4	5/8-11unc	6	9.5	4.3	8	3.6	
4	100	3.25	.437	.562	8	5/8-11unc	7 1/2	15	6.8	11	5.0	
5	125	3.25	.437	.656	8	3/4-10unc	8 1/2	21	9.5	15	6.8	
6	150	3.25	.437	.656	8	3/4-10unc	9 1/2	24	10.9	18	8.2	
8	200	3.25	.437	.781	8	3/4-10unc	11 3/4	34	15.4	28	12.7	
10	250	5.00	.562	1.000	12	7/8-9unc	14 1/4	62	28.1	45.5	20.7	
12	300	5.00	.562	1.062	12	7/8-9unc	17	90	40.9	70	31.8	

Refer to butterfly valve technical information for bolt lengths

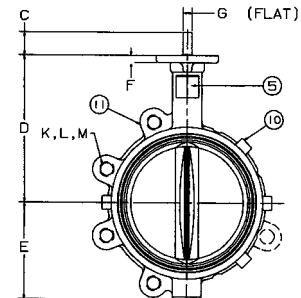

NOT RECOMMENDED FOR STEAM SERVICE

250 PSI Butterfly Valves

ductile iron body • extended neck • geometric drive • molded-in seat liner • lug and wafer style

Sizes 2" through 12"

Install between Std. ASME Class 125/150 flanges.
Lug style 232 PSI bi-directional dead end service rating without a downstream flange required.

DESIGNED TO MEET MSS SP-67 STANDARD
U.S. COAST GUARD "CATEGORY A"

MATERIAL LIST

PART	SPECIFICATION
1. Stem	Stainless Steel ASTM A582 Type 416
2. Collar Bushing	Brass ASTM B16
3. Stem Seal	Buna-N Rubber Nitrile
4. Body Seal	Buna-N Rubber Nitrile
5. Nameplate	Aluminum
6. Upper Bushing	Copper CDA 122
7. Liner	Buna-N Rubber Nitrile
8. Disc	Alum. Brz. ASTM B148 Alloy 954/955
9. Lower Bushing	Copper CDA 122
10. Body Wafer	Ductile Iron ASTM A536
11. Body Lug	Ductile Iron ASTM A536



WD 3100
Wafer Style
Buna-N Liner
and Aluminum
Bronze Disc

LD 3100
Lug Style
Buna-N Liner and
Aluminum
Bronze Disc

DIMENSIONS — WEIGHTS

Size		A	B	C	D	E	F	G	Metal	Rubber	J	N
In.	mm.							Flat	H	I	Square	Dia.
2	50	2.53	4.00	1.25	5.38	2.88	.38	.312	1.688	1.812	3.25	.500
2 1/2	65	2.90	4.69	1.25	5.88	3.27	.38	.370	1.812	1.938	3.25	.562
3	80	3.15	5.12	1.25	6.12	3.40	.38	.370	1.812	1.938	3.25	.562
4	100	4.09	6.12	1.25	6.88	4.00	.38	.403	2.062	2.188	3.25	.625
5	125	5.13	7.25	1.25	7.38	4.75	.38	.496	2.188	2.312	3.25	.750
6	150	6.13	8.25	1.25	8.00	5.29	.38	.496	2.188	2.312	3.25	.750
8	200	8.13	10.41	1.25	9.25	6.50	.50	.560	2.375	2.500	3.25	.875
10	250	10.13	12.52	1.25	10.50	8.00	.50	.686	2.688	2.812	4.75	1.125
12	300	12.13	15.00	1.25	12.00	9.25	.50	.748	3.000	3.125	4.75	1.250

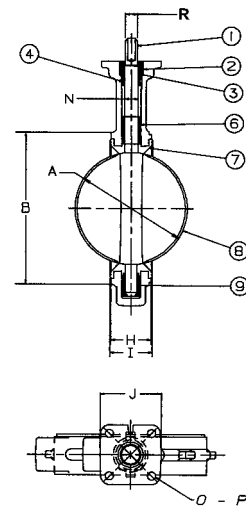

Capscrew/Stud Data

Size	O	P	R	K	L	Wafer	Lug	Lug		Wafer		
								Length	Length	Weight	Weight	
In.	mm.	B.C.	Dia.	No.	Dia.	Length	Length	Lbs.	Kg.	Lbs.	Kg.	
2	50	3.25	.437	.437	4	5/8-11unc	Refer to butterfly valve technical information for bolt lengths	4 3/4	7	3.2	2.5	
2 1/2	65	3.25	.437	.500	4	5/8-11unc		5 1/2	9	4.1	7.5	3.4
3	80	3.25	.437	.500	4	5/8-11unc		6	9.5	4.3	8	3.6
4	100	3.25	.437	.562	8	5/8-11unc		7 1/2	15	6.8	11	5.0
5	125	3.25	.437	.656	8	3/4-10unc		8 1/2	21	9.5	15	6.8
6	150	3.25	.437	.656	8	3/4-10unc		9 1/2	24	10.9	18	8.2
8	200	3.25	.437	.781	8	3/4-10unc		11 3/4	34	15.4	28	12.7
10	250	5.00	.562	1.000	12	7/8-9unc		14 1/4	62	28.1	45.5	20.7
12	300	5.00	.562	1.062	12	7/8-9unc		17	90	40.9	70	31.8

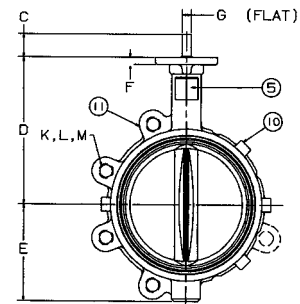

NOT RECOMMENDED
FOR STEAM SERVICE

250 PSI Butterfly Valves

ductile iron body • extended neck • geometric drive
molded-in seat liner • lug and wafer style

Sizes 2" through 12"

Install between Std. ASME Class 125/150 flanges.
Lug Style 250 PSI bi-directional dead end service rating without a downstream flange required.

DESIGNED TO MEET MSS SP-67 STANDARD
U.S. COAST GUARD "CATEGORY A"

MATERIAL LIST

PART	SPECIFICATION
1. Stem	Stainless Steel ASTM A582 Type 416
2. Collar Bushing	Brass ASTM B16
3. Stem Seal	Buna-N Rubber
4. Body Seal	Buna-N Rubber
5. Nameplate	Aluminum
6. Upper Bushing	Copper CDA 122
7. Liner	Buna-N Rubber
8. Disc	Ductile Iron ASTM A395 (Plated)
9. Lower Bushing	Copper CDA 122
10. Body Wafer	Ductile Iron ASTM A536
11. Body Lug	Ductile Iron ASTM A536

DIMENSIONS — WEIGHTS

Size		G						Metal		Rubber		J		N	
In.	mm.	A	B	C	D	E	F	Flat	H	I	Square	Diagonal	Diagonal	Diagonal	
2	50	2.53	4.00	1.25	5.38	2.88	.38	.312	1.688	1.812	3.25	.500			
2 1/2	65	2.90	4.69	1.25	5.88	3.27	.38	.370	1.812	1.938	3.25	.562			
3	80	3.15	5.12	1.25	6.12	3.40	.38	.370	1.812	1.938	3.25	.562			
4	100	4.09	6.12	1.25	6.88	4.00	.38	.403	2.062	2.188	3.25	.625			
5	125	5.13	7.25	1.25	7.38	4.75	.38	.496	2.188	2.312	3.25	.750			
6	150	6.13	8.25	1.25	8.00	5.29	.38	.496	2.188	2.312	3.25	.750			
8	200	8.13	10.41	1.25	9.25	6.50	.50	.560	2.375	2.500	3.25	.875			
10	250	10.13	12.52	1.25	10.50	8.00	.50	.686	2.688	2.812	4.75	1.125			
12	300	12.13	15.00	1.25	12.00	9.25	.50	.748	3.000	3.125	4.75	1.250			

Capscrew/Stud Data

Size	O	P	R	K	L	Wafer Length	Lug Length	M	Lug Weight		Wafer Weight	
									B.C.	Diagonal	Diagonal	Diagonal
2	50	3.25	.437	.437	4	5/8-11unc		4 3/4	7	3.2	5.5	2.5
2 1/2	65	3.25	.437	.500	4	5/8-11unc		5 1/2	9	4.1	7.5	3.4
3	80	3.25	.437	.500	4	5/8-11unc	Refer to butterfly valve technical information for bolt lengths	6	9.5	4.3	8	3.6
4	100	3.25	.437	.562	8	5/8-11unc		7 1/2	15	6.8	11	5.0
5	125	3.25	.437	.656	8	3/4-10unc		8 1/2	21	9.5	15	6.8
6	150	3.25	.437	.656	8	3/4-10unc		9 1/2	24	10.9	18	8.2
8	200	3.25	.437	.781	8	3/4-10unc		11 3/4	34	15.4	28	12.7
10	250	5.00	.562	1.000	12	7/8-9unc		14 1/4	62	28.1	45.5	20.7
12	300	5.00	.562	1.062	12	7/8-9unc		17	90	40.9	70	31.8

For actuated service where a lower torque is required use NIBCO Fig. No. WDLXXX-0 or LDLXXX-0 series, sizes 2" thru 12" only. Maximum pressure rating of 100 PSI for wet application and 50 PSI for dry application



WD 3110

Wafer Style
Buna-N Liner
and Ductile Disc

LD 3110

Lug Style
Buna-N Liner
and Ductile Disc

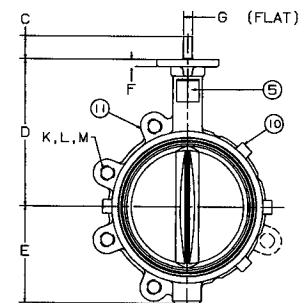
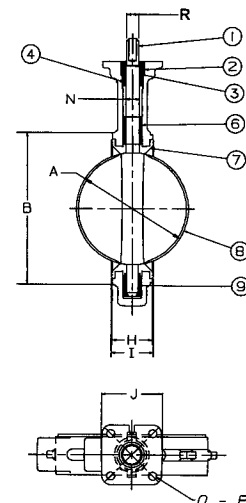

NOT RECOMMENDED
FOR STEAM SERVICE

250 PSI Butterfly Valves

ductile iron body • extended neck • geometric drive • 316 S.S. trim
molded-in seat liner • lug and wafer style

Sizes 2" through 12"

Install between Std. ASME Class 125/150 flanges.
Lug Style 250 PSI bi-directional dead end service rating without a
downstream flange required.

DESIGNED TO MEET MSS SP-67 STANDARD
U.S. COAST GUARD "CATEGORY A"
LD/WD-3022 THIRD PARTY CERTIFIED TO NSF/ANSI 61 AND 372

MATERIAL LIST

PART	SPECIFICATION
1. Stem	Stainless Steel ASTM A564 Type 17-4PH
2. Collar Bushing	Stainless Steel ASTM A276 Type 316
3. Stem Seal	Options: See Below*
4. Body Seal	Options: See Below*
5. Nameplate	Aluminum
6. Upper Bushing	Stainless Steel ASTM A276 Type 316
7. Liner	Options: See Below*
8. Disc	Stainless Steel ASTM A743 Grade CF8M
9. Lower Bushing	Stainless Steel ASTM A276 Type 316
10. Body Wafer	Ductile Iron ASTM A536
11. Body Lug	Ductile Iron ASTM A536

*Optional Liners/Seals: 0 - EPDM 1 - Buna-N (Nitrile) 2 - Fluoroelastomer



WD 3*22
Wafer Style
Optional Liner
and CF8M Disc



LD 3*22
Lug Style
Optional Liner
and CF8M Disc

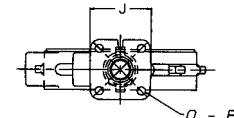
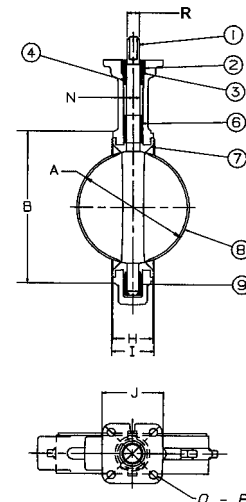

DIMENSIONS — WEIGHTS

Size		A	B	C	D	E	F	G	Metal	Rubber	J	N
In.	mm.							Flat	H	I	Square	Dia.
2	50	2.53	4.00	1.25	5.38	2.88	.38	.312	1.688	1.812	3.25	.500
2 1/2	65	2.90	4.69	1.25	5.88	3.27	.38	.370	1.812	1.938	3.25	.562
3	80	3.15	5.12	1.25	6.12	3.40	.38	.370	1.812	1.938	3.25	.562
4	100	4.09	6.12	1.25	6.88	4.00	.38	.403	2.062	2.188	3.25	.625
5	125	5.13	7.25	1.25	7.38	4.75	.38	.496	2.188	2.312	3.25	.750
6	150	6.13	8.25	1.25	8.00	5.29	.38	.496	2.188	2.312	3.25	.750
8	200	8.13	10.41	1.25	9.25	6.50	.50	.560	2.375	2.500	3.25	.875
10	250	10.13	12.52	1.25	10.50	8.00	.50	.686	2.688	2.812	4.75	1.125
12	300	12.13	15.00	1.25	12.00	9.25	.50	.748	3.000	3.125	4.75	1.250

Capscrew/Stud Data

Size	O	P	R	K	L	Wafer	Lug	M	Lug		Wafer	
									Length	Length	Weight	Weight
In. mm.	B.C.	Dia.	Dia.	No.	Dia.	Length	Length	B.C.	Lbs.	Kg.	Lbs.	Kg.
2 50	3.25	.437	.437	4	5/8-11unc	Refer to butterfly valve technical information for bolt lengths	4 3/4	7	3.2	5.5	2.5	
2 1/2 65	3.25	.437	.500	4	5/8-11unc		5 1/2	9	4.1	7.5	3.4	
3 80	3.25	.437	.500	4	5/8-11unc		6	9.5	4.3	8	3.6	
4 100	3.25	.437	.562	8	5/8-11unc		7 1/2	15	6.8	11	5.0	
5 125	3.25	.437	.656	8	3/4-10unc		8 1/2	21	9.5	15	6.8	
6 150	3.25	.437	.656	8	3/4-10unc		9 1/2	24	10.9	18	8.2	
8 200	3.25	.437	.781	8	3/4-10unc		11 3/4	34	15.4	28	12.7	
10 250	5.00	.562	1.000	12	7/8-9unc		14 1/4	62	28.1	45.5	20.7	
12 300	5.00	.562	1.062	12	7/8-9unc	17	90	40.9	70	31.8		

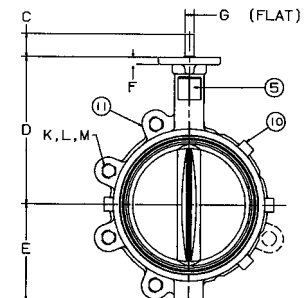

For actuated service where a lower torque is required use NIBCO Fig. No. WDLXXX-0 or LDLXXX-0 series, sizes 2" thru 12" only. Maximum pressure rating of 100 PSI for wet application and 50 PSI for dry application.

NOT RECOMMENDED
FOR STEAM SERVICE

250 lb. WWP UL/FM Butterfly Valves

fire protection valve • wafer or lug style body • molded in seat • accepts internal supervisory switches

250 PSI/17.2 bar non-shock cold water

- DESIGNED TO MEET MSS SP-67 STANDARD • UL/ULC LISTED • FMRC APPROVED • UL LISTED FOR INDOOR AND OUTDOOR SERVICE
- APPROVED BY NEW YORK CITY MEA 9-97-E, VOL.2 WHEN ASSEMBLED WITH APPROPRIATE NYC INDICATOR FLAG
 - CALIFORNIA STATE FIRE MARSHAL LISTING NO. 7770-1243:104
 - U.S. COAST GUARD "CATEGORY A"

MATERIAL LIST

PART	SPECIFICATION
1. Stem	Stainless Steel ASTM 582 Type 416
2. Collar Bushing	Brass ASTM B16
3. Upper Bushing	Copper Alloy CDA 122
4. Stem Seal	EPDM
5. Body Seal	EPDM
6. Disc	Ductile Iron ASTM 395 (Nickel Plated)
7. Liner	EPDM
8. Lower Bushing	Copper Alloy CDA 122
9. Nameplate	Aluminum
10. Body	Ductile Iron ASTM A536
11. Gear Operator	Cast Iron and Steel
12. Indicator Flag	Cast Iron
13. Handwheel	Cast Iron

** -8 version has two factory mounted internal supervisory switches.

-4 version no switches.

Note: wafer body will mate with ANSI or ISO flanges. O.D. of wafer body notched to fit ISO bolt circle.

Lug body available with ISO flange dimensions and metric bolt hole threads.

For dead-end service use lug style (rated 200 PSI for this service).

DIMENSIONS—WEIGHTS—QUANTITIES

Size	Dimensions																				
	A	B	C	D	E	F	G	H	I	J											
2	50	2.53	64	4.88	124	4.62	117	5.38	137	2.88	73	6.89	175	12.75	324	1.68	43	1.81	46	2.91	74
2½	65	2.90	74	5.62	143	5.12	130	5.88	149	3.25	83	7.36	187	13.63	346	1.81	46	1.94	49	2.91	74
3	80	3.17	81	6.12	155	5.50	140	6.12	155	3.38	86	7.60	193	14.00	356	1.81	46	1.94	49	2.91	74
4	100	4.17	106	7.00	178	8.25	210	6.88	175	4.00	102	8.39	213	15.38	391	2.06	52	2.19	56	2.91	74
5	125	5.17	131	8.25	210	9.38	238	7.38	187	4.75	121	8.86	225	16.63	422	2.19	56	2.31	59	2.91	74
6	150	6.17	157	9.25	235	10.25	260	8.00	203	5.25	133	9.49	241	17.75	451	2.19	56	2.31	59	2.91	74
8	200	8.17	208	11.62	295	12.38	314	9.25	235	6.50	165	10.75	273	20.25	514	2.38	60	2.50	64	2.91	74
10	250	10.17	258	14.25	362	15.50	394	10.50	267	8.00	203	12.28	312	23.50	597	2.68	69	2.81	71	3.90	99
12	300	12.17	309	16.75	425	18.25	464	12.00	305	9.25	235	13.78	350	26.25	667	3.00	76	3.12	79	3.90	99

Size	Dimensions					Flange/Stud Data			Weight									
	K	M	N	P		Dia.	Wafer	Lug	BC	Lug	Wafer							
2	50	3.54	90	5.82	148	2.13	54	5.9	150	4	5/8	16	4.75	121	23	11	21	10
2½	65	3.54	90	5.82	148	2.13	54	5.9	150	4	5/8	16	5.50	140	25	11	24	11
3	80	3.54	90	5.82	148	2.13	54	5.9	150	4	5/8	16	6.00	152	26	12	24	11
4	100	3.54	90	5.82	148	2.13	54	5.9	150	8	5/8	16	7.50	191	31	14	27	12
5	125	3.54	90	7.64	194	2.13	54	5.9	150	8	¾	20	8.50	216	37	17	31	14
6	150	3.54	90	7.64	194	2.13	54	5.9	150	8	¾	20	9.50	241	40	18	34	15
8	200	3.54	90	7.91	201	2.13	54	9.8	250	8	¾	20	11.75	298	55	25	49	22
10	250	3.98	101	9.49	241	3.03	77	11.8	300	12	7/8	22	14.25	362	95	43	78	35
12	300	3.98	101	9.49	241	3.03	77	11.8	300	12	7/8	22	17.00	432	123	56	103	47

Refer to butterfly valve technical information for bolt lengths



WD3510-8**

Wafer
(4" Shown)

LD3510-8**

Lug
(Not Shown)

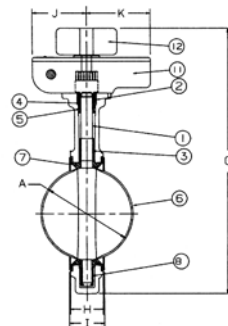
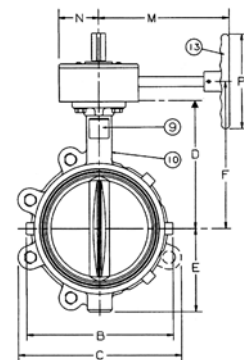

(10" Shown)



250 PSI WWP UL/FM Butterfly Valves

Designed for normally closed position monitoring

fire protection valve • lug or wafer style body • factory mounted monitoring switches • mates with C.I. Class 125 and Steel Class 150 flanges

250 PSI/17.2 bar non-shock cold water

UL/ULC LISTED** • FM APPROVED** •
DESIGNED TO MEET MSS SP-67 STANDARD

2½" - 8" UL LISTED FOR INDOOR AND OUTDOOR SERVICE

Warning: these valves are not to be used between the water source and sprinkler head.

MATERIAL LIST

PART	SPECIFICATION
1. Stem	Stainless Steel ASTM 582 Type 416
2. Collar Bushing	Brass ASTM B16
3. Upper Bushing	Copper Alloy CDA 122
4. Stem Seal	EPDM
5. Body Seal	EPDM
6. Disc	Ductile Iron ASTM 395 (Nickel Plated)
7. Liner	EPDM
8. Lower Bushing	Copper Alloy CDA 122
9. Nameplate	Aluminum
10. Body	Ductile Iron ASTM A536
11. Gear Operator	Cast Iron and Steel
12. Indicator Flag	Cast Iron
13. Handwheel	Cast Iron

Note: wafer body will mate with ANSI or ISO flanges. O.D. of wafer body notched to fit ISO bolt circle.
For dead-end service use lug style (rated 200 PSI for this service).

Comes with two factory mounted internal supervisory switches. Use switch Figure No. TS-4. See page 4 of I & M manual for installation & wiring instructions



LD-3510-C-8



WD-3510-C-8

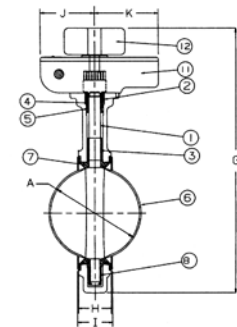
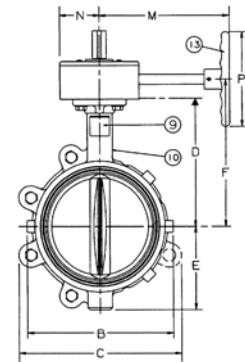

DIMENSIONS—WEIGHTS—QUANTITIES

Size	Dimensions										
	A	B	C	D	E	F	G	H	I	J	
In. mm.	In. mm.	In. mm.	In. mm.	In. mm.	In. mm.	In. mm.	In. mm.	In. mm.	In. mm.	In. mm.	
2½	65 2.90 74	5.62 143	5.12 130	5.88 149	3.25 83	7.36 187	13.63 346	1.81 46	1.94 49	2.91 74	
3	80 3.17 81	6.12 155	5.50 140	6.12 155	3.38 86	7.60 193	14.00 356	1.81 46	1.94 49	2.91 74	
4	100 4.17 106	7.00 178	8.25 210	6.88 175	4.00 102	8.39 213	15.38 391	2.06 52	2.19 56	2.91 74	
6	150 6.17 157	9.25 235	10.25 260	8.00 203	5.25 133	9.49 241	17.75 451	2.19 56	2.31 59	2.91 74	
8	200 8.17 208	11.62 295	12.38 314	9.25 235	6.50 165	10.75 273	20.25 514	2.38 60	2.50 64	2.91 74	

Size	Dimensions				Flange/Stud Data				Weight		
	K	M	N	P	Dia	Wafer	Lug	BC	Lug	Wafer	
In. mm.	In. mm.	In. mm.	In. mm.	In. mm.	No.	In. mm.	In. mm.	In. mm.	In. mm.	Lbs. Kg.	Lbs. Kg.
2½	65 3.54 90	5.82 148	2.13 54	5.9 150	4 5/8	16 4.25 108	1.50 38	5.50 140	25 11	24 11	
3	80 3.54 90	5.82 148	2.13 54	5.9 150	4 5/8	16 4.25 108	1.50 38	6.00 152	26 12	24 11	
4	100 3.54 90	5.82 148	2.13 54	5.9 150	8 5/8	16 5.00 127	2.00 51	7.50 191	31 14	27 12	
6	150 3.54 90	7.64 194	2.13 54	5.9 150	8 3/4	20 5.25 133	2.00 51	9.50 241	40 18	34 15	
8	200 3.54 90	7.91 201	2.13 54	9.8 250	8 3/4	20 5.75 146	2.25 57	11.75 298	55 25	49 22	

**Compliance with standards for butterfly valves for fire protection UL1091 & FM1112



285 PSI Butterfly Valves

ductile iron body • extended neck • geometric drive
molded-in seat liner • lug and wafer style
(not intended for air lines)

Sizes 2" through 12"

Install between Std. ASME Class 125/150 flanges.
250 PSI Bi-directional dead end service with no need
for a downstream flange.

DESIGNED TO MEET MSS SP-67 STANDARD
US COAST GUARD "CATEGORY A"

MATERIAL LIST

PART	SPECIFICATION
1. Stem	Stainless Steel ASTM A582 Type 416
2. Collar Bushing	Stainless Steel ASTM A236 Type 316
3. Stem Seal	EPDM Rubber
4. Body Seal	EPDM Rubber
5. Nameplate	Aluminum
6. Upper Bushing	Stainless Steel ASTM A276 Type 316
7. Liner	EPDM Rubber
8. Disc	Stainless Steel ASTM 743 Grade CF8M
9. Lower Bushing	Stainless Steel ASTM A276 Type 316
10. Body Wafer	Ductile Iron ASTM A536
11. Body Lug	Ductile Iron ASTM A536

DIMENSIONS — WEIGHTS

Size	A		B		C		D		E		F		G		H		I		J		N	
In. mm.	In. mm.		In. mm.		In. mm.		In. mm.		In. mm.		In. mm.		In. mm.		In. mm.		In. mm.		In. mm.		In. mm.	
2 50	2.53	4.00	1.25	5.38	2.88	.38	.312	1.688	1.812	1.812	1.938	3.25	.500									
2 1/2 65	2.90	4.69	1.25	5.88	3.27	.38	.370	1.812	1.938	1.938	3.25	.562										
3 80	3.15	5.12	1.25	6.12	3.40	.38	.370	1.812	1.938	1.938	3.25	.562										
4 100	4.09	6.12	1.25	6.88	4.00	.38	.403	2.062	2.188	2.188	3.25	.625										
5 125	5.13	7.25	1.25	7.38	4.75	.38	.496	2.188	2.312	2.312	3.25	.750										
6 150	6.13	8.25	1.25	8.00	5.29	.38	.496	2.188	2.312	2.312	3.25	.750										
8 200	8.13	10.41	1.25	9.25	6.50	.50	.560	2.375	2.500	2.500	3.25	.875										
10 250	10.13	12.52	1.25	10.50	8.00	.50	.686	2.688	2.812	2.812	4.75	1.125										
12 300	12.13	15.00	1.25	12.00	9.25	.50	.748	3.000	3.125	3.125	4.75	1.250										

Size	Capscrew/Stud Data						Wafer Length	Lug Length	M B.C.	Lug Weight		Wafer Weight	
	O B.C.	P Dia.	R Dia.	K No.	L Dia.	Wafer Length				Lug Length	Lbs.	Kg.	Lbs.
2 50	3.25	.437	.437	4	5/8-11unc	Refer to BFV Technical Information for bolt lengths	4 3/4	7	3.2	5.5	2.5		
2 1/2 65	3.25	.437	.500	4	5/8-11unc		5 1/2	9	4.1	7.5	3.4		
3 80	3.25	.437	.500	4	5/8-11unc		6	9.5	4.3	8	3.6		
4 100	3.25	.437	.562	8	5/8-11unc		7 1/2	15	6.8	11	5.0		
5 125	3.25	.437	.656	8	3/4-10unc		8 1/2	21	9.5	15	6.8		
6 150	3.25	.437	.656	8	3/4-10unc		9 1/2	24	10.9	18	8.2		
8 200	3.25	.437	.781	8	3/4-10unc		11 3/4	34	15.4	28	12.7		
10 250	5.00	.562	1.000	12	7/8-9unc		14 1/4	62	28.1	45.5	20.7		
12 300	5.00	.562	1.062	12	7/8-9unc		17	90	40.9	70	31.8		



WD 5022
Wafer Style
EPDM Liner
and Stainless
Steel Disc

LD 5022
Lug Style
EPDM Liner
and Stainless
Steel Disc

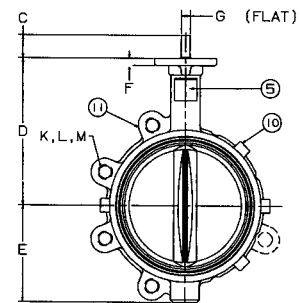
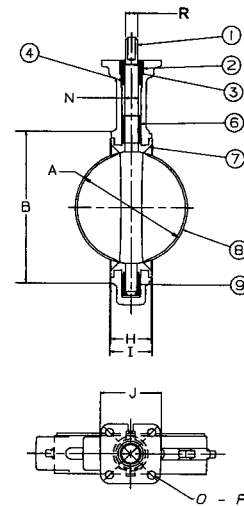

NOT RECOMMENDED
FOR STEAM SERVICE

Large Diameter Butterfly Valves

LD1000/2000 Series

Ductile Iron

Lug body

EPDM or Buna-N liner materials

- 14" thru 48" size range
- 150/200 PSI WOG
- Bubble tight shut off at full rated pressure
- Bidirectional dead end service
Sizes 14" - 24" 150 psi
Sizes 30" - 48" 100 psi
- Extended neck for 2" of insulation
- Aluminum bronze, 316SS, nickel plated ductile iron disc
- 416 stainless steel stem
- Designed to meet MSS SP-67 standard



150 PSI Butterfly Valves

ductile iron body • cartridge liner • lug style

Sizes 14", 16", 18", 20", and 24"

Install between Std. ASME Class 125/150 flanges. 150 PSI bi-directional dead end service rating without a downstream flange. Do NOT install between AWWA C115/A21.5 type flanges.

DESIGNED TO MEET MSS SP-67 STANDARD

- CERTIFIED LEAD -FREE* BY IAPMO R&T TO NSF/ANSI 372

MATERIAL LIST

PART	SPECIFICATION
1. Screw	Steel, ANSI 1035 (2) 16" & 18" (4) 20" & 24"
2. Bottom Plate	Ductile Iron ASTM A536 grade 65-45-12
3. O-ring	Nitrile ASTM D2000
4. Body	Ductile Iron ASTM a536 grade 65-45-12
5. Long Bushing	Bronze ASTM B584 UNS C83600 Stainless Steel ASTM A276 UNS s31600
6. Stem	Stainless Steel ASTM A582 UNS S41600 Stainless Steel ASTM A276 UNS S31600 Stainless Steel ASTM A276 UNS S43100
7. Disc	Aluminum bronze ASTM B148 UNS C95400 Ductile Iron ASTM A536 grade 65-45-12 Nickel Plated Stainless Steel ASTM A351 CF8M
8. Taper Pin (2)	Stainless Steel ASTM A564 UNS S17400 Stainless Steel ASTM A276 UNS S31600
9. Seat	Nitrile ASTM D2000 EPDM ASTM D2000
10. Nameplate	Aluminum
11. Short Bushing (2)	Bronze ASTM B584 UNS C83600 Stainless Steel ASTM A276 UNS S31600
12. O-ring	Nitrile ASTM D2000
13. Key	Steel, ASTM A108 UNS C10450
14. Screw	Steel, ANSI 1035 (6) 14" thru 18" (8) 20" & 24"

DIMENSIONS — WEIGHTS

Size	A	Minimum.	B	C				G	H	I
In. mm	Dia.	Pipe I.D.	Dia.	Dia.	D	E	F	Body	Seat	Dia.
14" 350	13.12	13.02	14.77	17.20	14.49	1.77	26.77	3.00	3.13	1.244
16" 400	15.34	15.20	17.30	19.21	15.75	2.02	29.93	3.37	3.54	1.305
18" 450	17.34	17.09	19.31	21.22	16.61	2.02	31.54	4.12	4.29	1.494
20" 500	19.36	18.90	21.08	23.31	18.90	2.53	35.64	5.13	5.31	1.619
24" 600	23.33	23.05	25.71	32.09	22.13	2.76	42.96	5.96	6.14	1.993

DIMENSIONS — WEIGHTS

Size	J	K	L	M	P	Q	R	T	WEIGHT	
In. mm	Dia.	Dia.	Dia.	Drive Key		Dia.	Dia.	In.	Lbs.	Kg
14"	350	5.51	4.25	0.55	.250 x 1.125 WOODRUFF #809	12	1"-8 UNC	18.75	17.52	141 64
16"	400	7.76	6.25	0.83	.312 X .312 X 1.811 LONG	16	1"-8 UNC	21.25	20.08	199 90
18"	450	7.76	6.25	0.83	.375 X .375 X 1.881 LONG	16	1-1/8"-7 UNC	22.75	21.26	261 119
20"	500	7.76	6.25	0.83	.375 x .375 x 1.811 LONG	20	1-1/8"-7 UNC	25.00	24.02	395 179
24"	600	10.87	8.50	0.94	.500 x .500 x 2.362 LONG	20	1-1/4"-7 UNC	29.50	27.87	591 268

LD 1000/LD 1100

Lug Style
EPDM or Buna-N Liner
Aluminum Bronze Disc

LD 1010/LD 1110

Lug Style
EPDM or Buna-N Liner
Ductile Iron Disc

LD 1022/LD 1122

Lug Style
EPDM or Buna-N Liner
Stainless Steel Disc

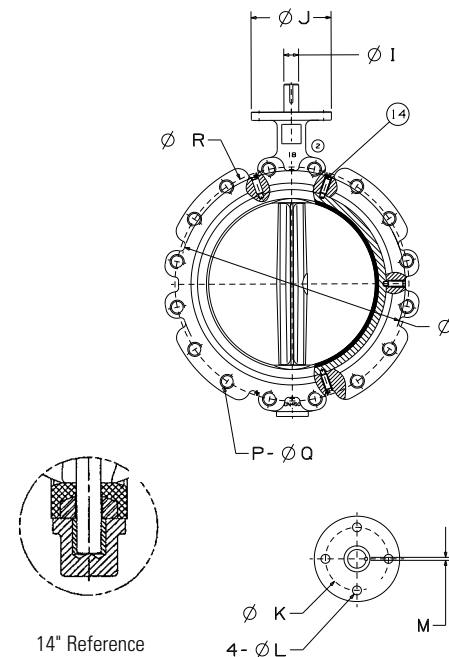
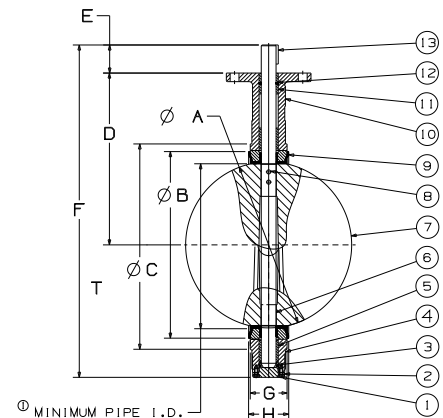

NOT RECOMMENDED
FOR STEAM SERVICE

*Weighted average lead content ≤ 0.25%

200 PSI Butterfly Valves

ductile iron body • cartridge liner • lug style

Sizes 14", 16", 18", 20", and 24"

Install between Std. ASME Class 125/150 flanges. 150 PSI bi-directional dead end service rating without a downstream flange. Do NOT install between AWWA C115/A21.5 type flanges.

DESIGNED TO MEET MSS SP-67 STANDARD

- CERTIFIED LEAD -FREE* BY IAPMO R&T TO NSF/ANSI 372

MATERIAL LIST

PART	SPECIFICATION
1. Screw	Steel, ANSI 1035 (2) 16" & 18" (4) 20" & 24"
2. Bottom Plate	Ductile Iron ASTM A536 grade 65-45-12
3. O-ring	Nitrile ASTM D2000
4. Body	Ductile Iron ASTM a536 grade 65-45-12
5. Long Bushing	Bronze ASTM B584 UNS C83600 Stainless Steel ASTM A276 UNS s31600
6. Stem	Stainless Steel ASTM A582 UNS S41600 Stainless Steel ASTM A276 UNS S31600 Stainless Steel ASTM A276 UNS S43100
7. Disc	Aluminum bronze ASTM B148 UNS C95400 Ductile Iron ASTM A536 grade 65-45-12 Nickel Plated Stainless Steel ASTM A351 CF8M
8. Taper Pin (2)	Stainless Steel ASTM A564 UNS S17400 Stainless Steel ASTM A276 UNS S31600
9. Seat	Nitrile ASTM D2000 EPDM ASTM D2000
10. Nameplate	Aluminum
11. Short Bushing (2)	Bronze ASTM B584 UNS C83600 Stainless Steel ASTM A276 UNS S31600
12. O-ring	Nitrile ASTM D2000
13. Key	Steel, ASTM A108 UNS C10450
14. Screw	Steel, ANSI 1035 (6) 14" thru 18" (8) 20" & 24"

DIMENSIONS — WEIGHTS

Size	A	Minimum.	B	C				G	H	I	
In. mm	mm	Pipe I.D.	mm	mm	D	E	F	Body	Seat	mm	
14"	350	13.12	13.02	14.77	17.20	14.49	1.77	26.77	3.00	3.13	1.244
16"	400	15.34	15.20	17.30	19.21	15.75	2.02	29.93	3.37	3.54	1.305
18"	450	17.34	17.09	19.31	21.22	16.61	2.02	31.54	4.12	4.29	1.494
20"	500	19.36	18.90	21.08	23.31	18.90	2.53	35.64	5.13	5.31	1.619
24"	600	23.33	23.05	25.71	32.09	22.13	2.76	42.96	5.96	6.14	1.993

DIMENSIONS — WEIGHTS

Size	J	K	L	M	P	Q	R	T	WEIGHT		
In. mm	mm	mm	mm	Drive Key	mm	mm	mm	In.	Lbs.	Kg	
14"	350	5.51	4.25	0.55	.250 x 1.125 WOODRUFF #809	12	1"-8 UNC	18.75	17.52	141	64
16"	400	7.76	6.25	0.83	.312 X.312 X 1.811 LONG	16	1"-8 UNC	21.25	20.08	199	90
18"	450	7.76	6.25	0.83	.375 X .375 X 1.881 LONG	16	1-1/8"-7 UNC	22.75	21.26	261	119
20"	500	7.76	6.25	0.83	.375 x .375 x 1.811 LONG	20	1-1/8"-7 UNC	25.00	24.02	395	179
24"	600	10.87	8.50	0.94	.500 x .500 x 2.362 LONG	20	1-1/4"-7 UNC	29.50	27.87	591	268

*LD 2022, 2122, SSTRIM not available in 24"

*Weighted average lead content ≤ 0.25%

LD 2000/LD 2100

Lug Style
EPDM or Buna-N Liner
Aluminum Bronze Disc

LD 2010/LD 2110

Lug Style
EPDM or Buna-N Liner
Ductile Iron Disc

LD 2022/LD 2122*

Lug Style
EPDM or Buna-N Liner
Stainless Steel Disc

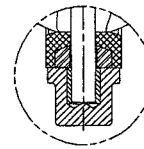
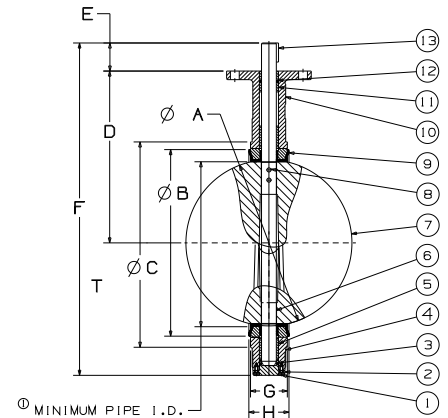

14" Reference Lower Shaft Well

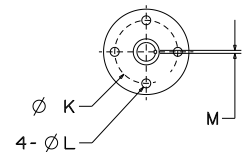
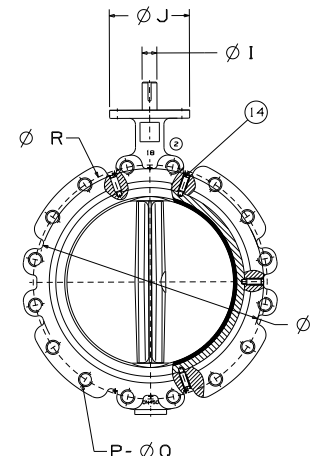

NOT RECOMMENDED FOR STEAM SERVICE

150 PSI Butterfly Valves

ductile iron body • cartridge liner • double flanged

Sizes 30", 36", 42" and 48"

Install between ANSI B16.10 Class 125 or ANSI B16.47 Class 150 flanges.
100 PSI bi-directional dead end service rating without a downstream flange.
Do NOT install between AWWA C115/A21.5 type flanges.

DESIGNED TO MEET MSS SP-67 STANDARD

MATERIAL LIST

PART	SPECIFICATION
1. Body	Ductile Iron ASTM A536
2. Bushing	Bronze ASTM B584 Grade C83600
3. Lower Stem	Stainless Steel ASTM A582 Type 416 Stainless Steel ASTM A276 Type 316SS
3a. Upper Stem	Stainless Steel ASTM A582 Type 416 Stainless Steel ASTM A276 Type 316SS
4. Seat Back Ring	Phenolic Resin, Aluminum B26 30" - 36" eight set screws in backing 42" - 48" ten set screws in backing
5. Seat	Rubber - BUNA (NBR) Rubber - EPDM
6. Disc	Aluminum Bronze ASTM B148 C95400 Ductile Iron ASTM A536 65-45-12 (Nickel Plated) Stainless Steel ASTM A351 Grade CF8M
7. Taper Pin (3)	Stainless Steel ASTM A582 Type 416 or ASTM 564
8. Rivet	Steel
9. Nameplate	Aluminum
10. Bushing	Bronze ASTM B584 C83600
11. Flat Key	Steel ASTM A108 1045
12. Bushing	Bronze ASTM B584 C83600
13. Socket Bolt	Steel ASTM A307
14. O-Ring	Rubber BUNA (NBR)
15. Bottom Plate	Steel ASTM A108 1035
16. Thrust Bearing	Bearing Steel
17. Washer	Steel

LD 1000/LD 1100

Lug Style
EPDM or Buna-N Liner
Aluminum Bronze Disc

LD 1010

Lug Style
EPDM Liner
Ductile Iron Disc

LD 1022

Lug Style
EPDM Liner
Stainless Steel Disc

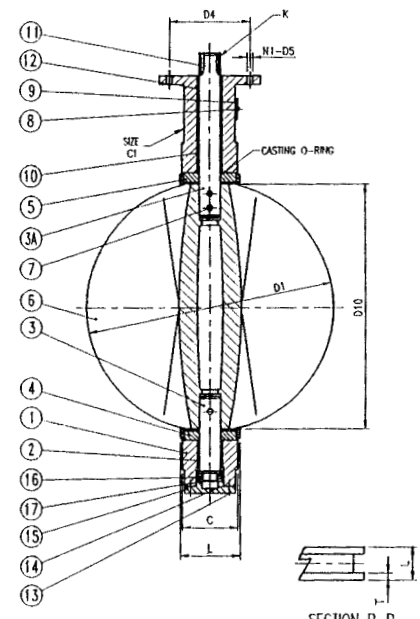
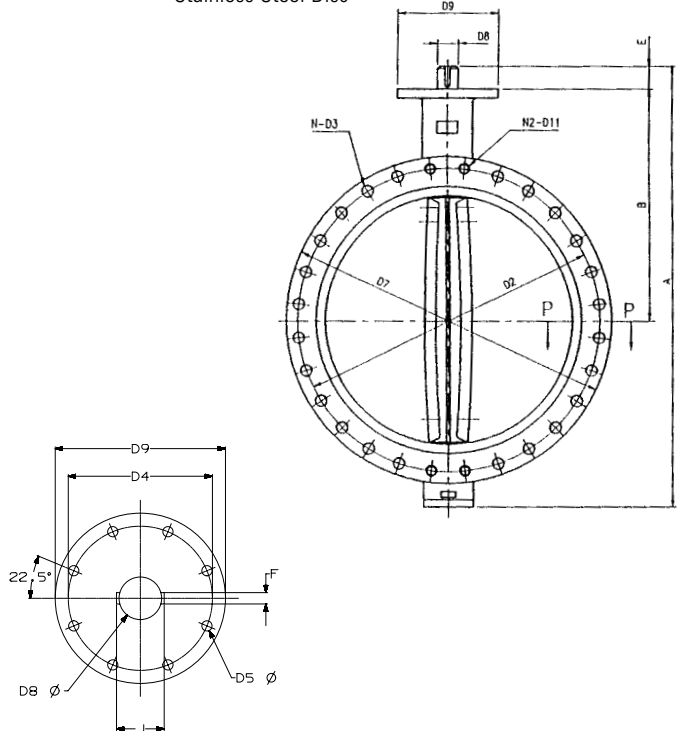

NOT RECOMMENDED FOR STEAM SERVICE

SECTION P-P

Size		D8										C
In.	mm.	D1	D2	D4	D5	D7	Dia.	D9	D10	D11		
30	750	29.30	36.00	10.00	0.71	38.74	2.50	11.81	28.56	11/4-7UNC		6.57
36	900	34.04	42.75	10.00	0.71	46.00	2.95	11.81	33.09	11/2-6UNC		8.00
42	1050	40.55	49.50	11.73	0.87	53.00	3.74	13.78	39.33	11/2-6UNC		9.88
48	1200	45.67	56.00	11.73	0.87	59.50	4.13	13.78	44.35	11/2-6UNC		10.88

Size		K										Weight	
In.	mm.	L	A	B	E	F	J	N1	N2	T	Key Size	Lbs.	Kg.
30	750	6.81	50.63	26.00	2.60	0.709	2.809	8	28	2.12	.709 x .433 x 2.50	926	420
36	900	8.31	58.82	28.35	4.65	0.787	3.307	8	32	2.38	.787 x .472 x 4.00	1482	660
42	1050	10.28	70.28	33.78	5.91	0.984	4.134	8	36	2.62	.984 x .551 x 4.50	1971	896
48	1200	11.26	76.96	37.04	5.91	1.102	4.606	8	44	2.75	1.104 x .630 x 4.50	2816	1280

Cast Iron Butterfly Valves

WC/LC2000 Series

- **Cast Iron**

Lug or wafer body

- EPDM liner materials
- 2" thru 12" size range
- 200 PSI CWP
- Bubble tight shut off at full rated pressure
- Aluminum bronze disc
- 416 stainless steel stem



N200 Series

- **Cast Iron**

Lug or wafer body

- EPDM or Buna-N liner materials
- 2" thru 12" size range
- 200 PSI CWP
- Bubble tight shut off at full rated pressure
- Aluminum bronze or nickel plated ductile iron disc
- 416 stainless steel stem



Note - Stem extensions for this butterfly series are not available.

200 PSI Butterfly Valves

cast iron body • extended neck • geometric drive
molded-in seat liner • lug and wafer style



Sizes 2" through 12"

Install between Std. ASME Class 125/150 flanges†.
Lug Style 200 PSI bi-directional dead end service rating without a downstream flange required.

DESIGNED TO MEET MSS SP-67 STANDARD
US COAST GUARD "CATEGORY A" • CERTIFIED LEAD-FREE* BY
TRUESDAIL LABS TO NSF/ANSI 61-8 COMMERCIAL HOT 180°F
(INCLUDES ANNEX F AND G) AND NSF/ANSI-372

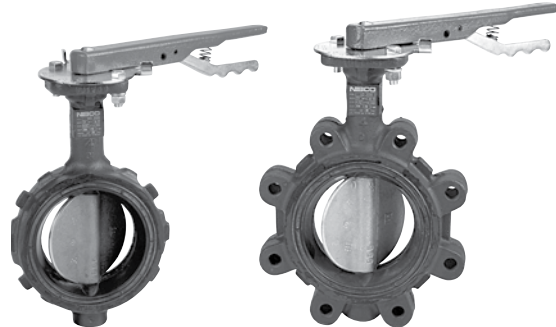

WC 2000
Wafer Style
EPDM Liner
and Aluminum
Bronze Disc

LC 2000
Lug Style
EPDM Liner
and Aluminum
Bronze Disc

MATERIAL LIST

PART	SPECIFICATION
1. Stem	Stainless Steel ASTM A582 Type 416
2. Collar Bushing	Brass ASTM B16
3. Stem Seal	EPDM Rubber
4. Body Seal	EPDM Rubber
5. Nameplate	Aluminum
6. Upper Bushing	Copper CDA 122
7. Liner	EPDM Rubber
8. Disc	Alum. Brz. ASTM B148 Alloy 955
9. Lower Bushing	Copper CDA 122
10. Body Wafer	Cast Iron A126 Class B
11. Body Lug	Cast Iron A126 Class B

DIMENSIONS — WEIGHTS

Size	A	B	C	D	E	F	G Flat	Metal H	Rubber I	J Square	N Dia.	
2	50	2.53	4.00	1.25	5.38	2.88	.38	.312	1.688	1.812	3.25	.500
2 1/2	65	2.90	4.69	1.25	5.88	3.27	.38	.370	1.812	1.938	3.25	.562
3	80	3.15	5.12	1.25	6.12	3.40	.38	.370	1.812	1.938	3.25	.562
4	100	4.09	6.12	1.25	6.88	4.00	.38	.403	2.062	2.188	3.25	.625
5	125	5.13	7.25	1.25	7.38	4.75	.38	.496	2.188	2.312	3.25	.750
6	150	6.13	8.25	1.25	8.00	5.29	.38	.496	2.188	2.312	3.25	.750
8	200	8.13	10.41	1.25	9.25	6.50	.50	.560	2.375	2.500	3.25	.875
10	250	10.13	12.52	1.25	10.50	8.00	.50	.686	2.688	2.812	4.75	1.125
12	300	12.13	15.00	1.25	12.00	9.25	.50	.748	3.000	3.125	4.75	1.250

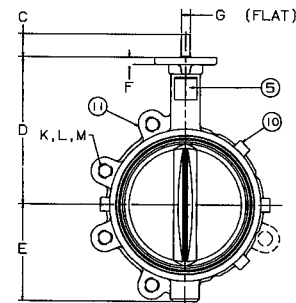
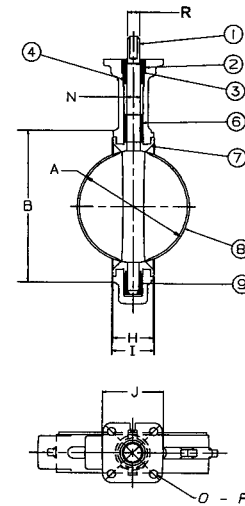

NOT RECOMMENDED FOR STEAM SERVICE

Size	Capscrew/Stud Data						Lug Weight		Wafer Weight			
	O B.C.	P Dia.	R Dia.	K No.	L Dia.	Wafer Length	Lug Length	M B.C.	Lbs.	Kg.	Lbs.	Kg.
2	50	3.25	.437	.437	4	5/8-11unc	Refer to butterfly valve technical information for bolt lengths	4 3/4	7	3.2	5.5	2.5
2 1/2	65	3.25	.437	.500	4	5/8-11unc		5 1/2	9	4.1	7.5	3.4
3	80	3.25	.437	.500	4	5/8-11unc		6	9.5	4.3	8	3.6
4	100	3.25	.437	.562	8	5/8-11unc		7 1/2	15	6.8	11	5.0
5	125	3.25	.437	.656	8	3/4-10unc		8 1/2	21	9.5	15	6.8
6	150	3.25	.437	.656	8	3/4-10unc		9 1/2	24	10.9	18	8.2
8	200	3.25	.437	.781	8	3/4-10unc		11 3/4	34	15.4	28	12.7
10	250	5.00	.562	1.000	12	7/8-9unc		14 1/4	62	28.1	45.5	20.7
12	300	5.00	.562	1.062	12	7/8-9unc		17	90	40.9	70	31.8

†NOTE: lug style valves - extra care should be used when installing with raised face flanges. Overtightening can result in broken lugs.

*Weighted average lead content ≤ 0.25%

200 PSI Butterfly Valves

cast iron body • extended neck
cartridge seat liner* • lug style

Sizes 2" through 12"

Install between Std. ASME Class 125/150 flanges†.
Bi-directional dead end service rating without a downstream
flange required: 2"-6" 200 PSI, 8" 150 PSI, 10"-12" 100 PSI.

DESIGNED TO MEET MSS SP-67 STANDARD

MATERIAL LIST

PART	SPECIFICATION
1. Body	Cast Iron, Epoxy coated ASTM A126 CL.B
2. Body Bushing	Bronze ASTM B584 Grade C83600
3. Liner	EPDM Rubber w/Phenolic Backing Buna-N Rubber Nitrile w/Phenolic Backing
4. Stem	Stainless Steel ASTM A582 Type 416
5. Disc	Alum. Brz. ASTM B148 Alloy C95400 Ductile Iron ASTM A536 Grade 65-45-12 (plated)
6. Taper Pin (2 pin 6" - 12")	Stainless Steel ASTM A582 Type 416
7. Name Plate	Aluminum
8. Shaft Bushing	Bronze ASTM B584 Grade C83600
9. Stem Seal	Buna-N Rubber Nitrile

DIMENSIONS — WEIGHTS

Size	A	Min.	B	C	E	F	G	H	I	
In. mm.	Dia.	Pipe I.D.	Dia.	Dia.	D		Body	Seat	Dia.	
2 50	2.08	1.38	3.00	3.94	6.34	1.26	10.75	1.655	1.81	0.496
2 1/2 65	2.54	1.95	3.50	4.72	6.89	1.26	11.65	1.759	1.93	0.496
3 80	3.10	2.66	4.09	5.00	7.13	1.26	12.12	1.780	1.93	0.496
4 100	4.10	3.67	5.32	6.14	7.87	1.26	13.62	2.050	2.18	0.621
5 125	4.85	4.48	6.26	7.48	8.39	1.26	14.65	2.140	2.31	0.745
6 150	6.12	5.84	7.42	8.35	8.90	1.26	15.62	2.195	2.33	0.745
8 200	7.97	7.85	9.38	10.55	10.24	1.77	18.88	2.385	2.52	0.870
10 250	9.86	9.76	11.51	12.79	11.50	1.77	21.26	2.584	2.83	1.120
12 300	11.87	11.72	13.55	15.87	13.27	1.77	24.57	3.029	3.19	1.244

Size	J	K	L	M	R	P	Q	T	Lug Weight
In. mm.	Dia.	B.C. Dia.	Dia.	Dia.	Dia.		Dia.	Flats	Lbs. Kg.
2 50	3.00	1.97	0.28	0.75	4.75	4	5/8-11UNC	.350	8.6 3.9
2 1/2 65	3.03	1.97	0.28	0.75	5.50	4	5/8-11UNC	.350	10.8 4.9
3 80	3.03	1.97	0.28	0.75	6.00	4	5/8-11UNC	.350	11.4 5.2
4 100	3.62	2.76	0.39	0.75	7.50	8	5/8-11UNC	.437	18.9 8.6
5 125	3.62	2.76	0.39	0.88	8.50	8	3/4-10UNC	.500	22.8 10.4
6 150	3.62	2.76	0.39	0.88	9.50	8	3/4-10UNC	.500	27.1 12.3
8 200	4.50	4.02	0.47	0.88	11.75	8	3/4-10UNC	.625	41.2 18.7
10 250	4.50	4.02	0.47	1.00	14.25	12	7/8-9UNC	.812	56.3 25.9
12 300	5.50	4.02	0.47	1.00	17.00	12	7/8-9UNC	.875	90.3 41.0

*Note: refer to NIBCO O & M manual for specified installation instructions for optimal performance of cartridge seat valves

†Note: lug style valves- extra care should be used when installing with raised face flanges. Over-tightening can result in broken lugs.

N200235
Lug Style
EPDM Liner
Aluminum Bronze Disc

N200236
Lug Style
EPDM Liner
Ductile Iron Disc

N200245
Lug Style
Buna Liner
Aluminum Bronze Disc

N200246
Lug Style
Buna Liner
Ductile Iron Disc

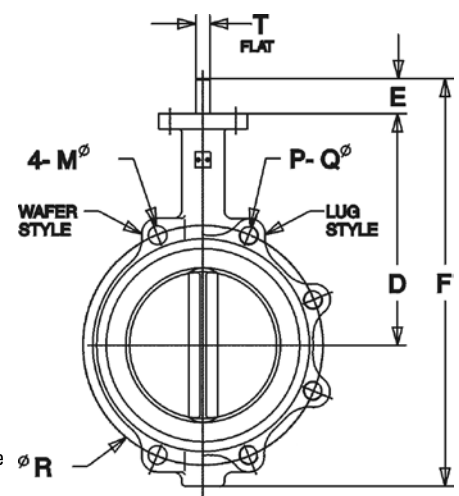
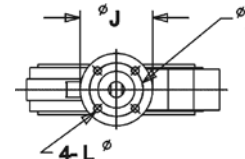
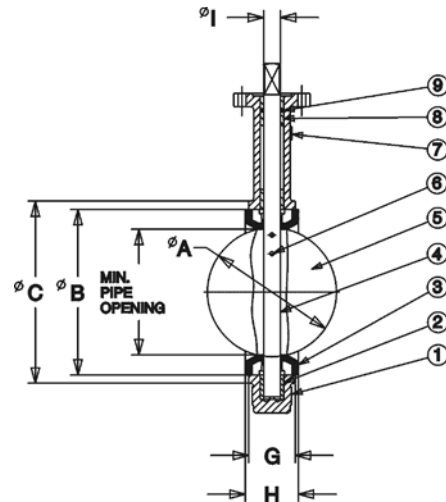

NOT RECOMMENDED FOR STEAM SERVICE

200 PSI Butterfly Valves

cast iron body • extended neck
cartridge seat liner* • wafer style

Sizes 2" through 12"

Install between Std. ASME Class 125/150 flanges.

DESIGNED TO MEET MSS SP-67 STANDARD

MATERIAL LIST

PART	SPECIFICATION
1. Body	Cast Iron, Epoxy coated ASTM A126 CL.B
2. Body Bushing	Bronze ASTM B584 Grade C83600
3. Liner	EPDM Rubber w/Phenolic Backing Buna-N Rubber Nitrile w/Phenolic Backing
4. Stem	Stainless Steel ASTM A582 Type 416
5. Disc	Alum. Brz. ASTM B148 Alloy C95400 Ductile Iron ASTM A536 Grade 65-45-12 (plated)
6. Taper Pin (2 pin 6" - 12")	Stainless Steel ASTM A582 Type 416
7. Name Plate	Aluminum
8. Shaft Bushing	Bronze ASTM B584 Grade C83600
9. Stem Seal	Buna-N Rubber Nitrile

DIMENSIONS — WEIGHTS

Size	A	Min.	B	C	G	H	I				
In. mm.	Dia.	Pipe I.D.	Dia.	Dia.	Body	Seat	Dia.				
2	50	2.08	1.38	3.00	3.94	6.34	1.26	10.75	1.655	1.81	0.496
2 1/2	65	2.54	1.95	3.50	4.72	6.89	1.26	11.65	1.759	1.93	0.496
3	80	3.10	2.66	4.09	5.00	7.13	1.26	12.12	1.780	1.93	0.496
4	100	4.10	3.67	5.32	6.14	7.87	1.26	13.62	2.050	2.18	0.621
5	125	4.85	4.48	6.26	7.48	8.39	1.26	14.65	2.140	2.31	0.745
6	150	6.12	5.84	7.42	8.35	8.90	1.26	15.62	2.195	2.33	0.745
8	200	7.97	7.85	9.38	10.55	10.24	1.77	18.90	2.385	2.52	0.870
10	250	9.86	9.76	11.51	12.79	11.50	1.77	21.26	2.584	2.83	1.120
12	300	11.87	11.72	13.55	15.87	13.27	1.77	24.57	3.029	3.19	1.244

Size	J	B.C.	L	M	R	Q	T	Lug Weight	
In. mm.	Dia.	Dia.	Dia.	Dia.	Dia.	Dia.	Flats	Lbs.	Kg.
2	50	3.00	2.25	0.28	0.75	4	5/8-11UNC	.350	5.7 2.6
2 1/2	65	3.03	2.25	0.28	0.75	5	5/8-11UNC	.350	7.5 3.9
3	80	3.03	2.25	0.28	0.75	6	5/8-11UNC	.350	8.4 3.8
4	100	3.62	2.75	0.39	0.75	8	5/8-11UNC	.437	12.3 5.6
5	125	3.62	2.75	0.39	0.88	8	3/4-10UNC	.500	17.2 7.8
6	150	3.62	2.75	0.39	0.88	8	3/4-10UNC	.500	19.6 8.9
8	200	4.50	3.50	0.47	0.88	11	3/4-10UNC	.625	29.7 13.5
10	250	4.50	3.50	0.47	1.00	12	7/8-9UNC	.812	44.0 20.0
12	300	5.50	4.25	0.47	1.00	12	7/8-9UNC	.875	65.8 29.9

*Note: refer to NIBCO O & M manual for specified installation instructions for optimal performance of cartridge seat valves

N200135
Wafer Style
EPDM Liner
Aluminum Bronze Disc

N200136
Wafer Style
EPDM Liner
Ductile Iron Disc

N200145
Wafer Style
Buna Liner
Aluminum Bronze Disc

N200146
Wafer Style
Buna Liner
Ductile Iron Disc

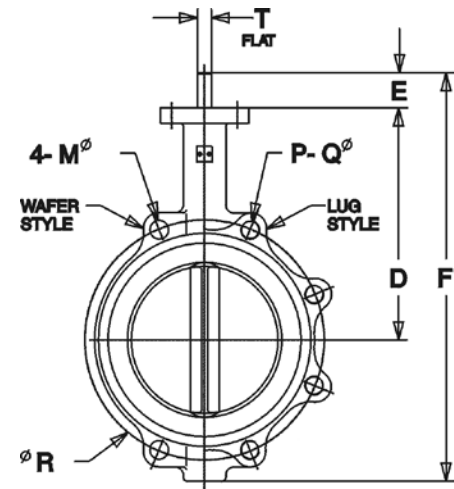
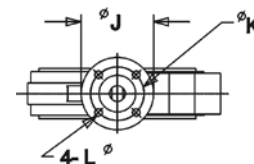
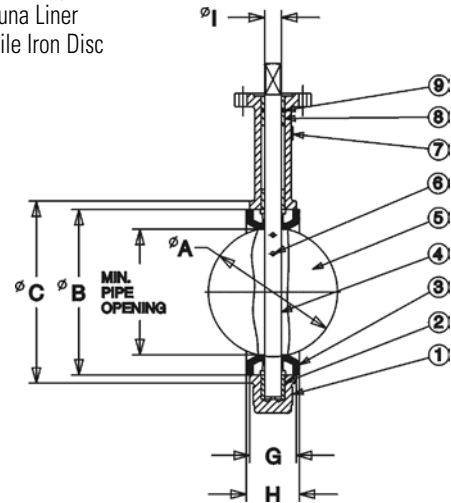

NOT RECOMMENDED
FOR STEAM SERVICE

Grooved Butterfly Valve

GD4765 Series

Polyamide Coated Ductile Iron body

Elastomer encapsulated disc (EPDM or Buna-N)

- Maximum temperature rating 200°F EPDM Disc and 180°F with Buna Disc
- 416 stainless steel stem
- 300 PSI WOG 2" thru 10"
- 200 PSI WOG 12"
- 175 PSI WOG 10" UL/FM
- UL & ULC listed, FM approved
- 2½" thru 10" UL listed for indoor and outdoor service
- UL/FM version accepts internal supervisory switches
- Designed to meet MSS SP-67 standard



300 PSI Grooved End Butterfly Valves

- polyamide coated ductile iron body • extended neck
- elastomer encapsulated disc • grooved mechanical style
- 12" maximum pressure rating 200 PSI • maximum temperature rating of 200°F EPDM disc and 180°F Buna disc • grooved end compatible with IPS pipe

Sizes 2" through 12"

DESIGNED TO MEET MSS SP-67 STANDARD

MATERIAL LIST

PART	SPECIFICATION
1. Upper Stem	Stainless Steel ASTM A582 Type 416
2. Upper Bearing	Split Metal
3. O-Ring	EPDM or Buna-N
4. Body	Ductile Iron ASTM A395 w/Polyamide Coating
5. Disc	Ductile Iron ASTM A395 w/EPDM or Buna-N Encapsulation
6. Lower Bearing	Split Metal
7. Lower Stem	Stainless Steel ASTM A582 Type 416
8. Dust Plug	PVC
9. Name Plate	Aluminum

Polyamide coating has NSF certification

DIMENSIONS — WEIGHTS

Size		A	B	C	D	E	F	G	J
In.	mm.								
2	50	2.38	2.32	.33	.63	3.33	2.42	.46	1.31
2 1/2	65	2.88	2.72	.31	.63	3.85	2.42	.46	1.22
3	80	3.50	3.34	.31	.63	3.85	2.86	.46	1.18
3 O.D.	76.1	3.00	2.84	.31	.63	3.85	2.42	.46	1.22
4	100	4.50	4.33	.38	.63	4.56	3.84	.46	1.24
5	125	5.56	5.39	.38	.63	5.86	4.79	.46	1.24
6	150	6.63	6.45	.38	.63	5.86	5.73	.46	1.29
6 1/2 O.D.	165.1	6.51	6.32	.38	.63	5.86	5.73	.46	1.29
8	200	8.63	8.44	.44	.75	5.26	7.71	.46	1.32
10	250	10.75	10.56	.50	.75	6.29	9.56	.70	1.38
12	300	12.76	12.51	.50	.75	6.52	11.55	.70	1.38

Size		K	L	M	N	P	Q	R	Weight	
In.	mm.								Lbs.	Kg.
2	50	3.25	.50	.37	4.00	3.14	.437	2.89	6.7	3.0
2 1/2	65	3.25	.50	.37	4.19	3.25	.437	3.46	7.5	3.4
3	80	3.25	.50	.37	4.44	3.54	.437	3.97	8.7	3.9
3 O.D.	76.1	3.25	.50	.37	4.19	3.25	.437	3.46	8.7	3.9
4	100	3.25	.66	.50	5.33	4.35	.437	5.03	12.2	5.5
5	125	3.25	.66	.50	5.83	4.84	.437	6.27	17.3	7.8
6	150	3.25	.78	.56	7.11	5.93	.437	7.25	27.4	12.4
6 1/2 O.D.	165.1	3.25	.78	.56	7.11	5.93	.437	7.25	27.4	12.4
8	200	3.25	.78	.56	8.05	6.87	.437	9.25	32.5	14.7
10	250	5.00	1.06	.75	9.86	9.17	.562	11.25	69.6	31.6
12	300	5.00	1.06	.75	10.85	10.17	.562	13.14	88.0	39.9

NOT RECOMMENDED
FOR STEAM SERVICE

GD 4765
w/EPDM Liner

GD 4775
w/Buna-N Liner

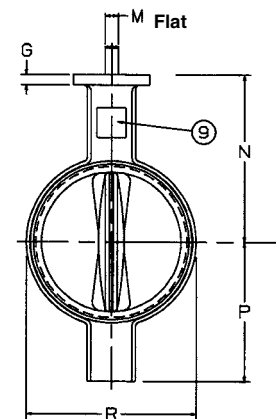
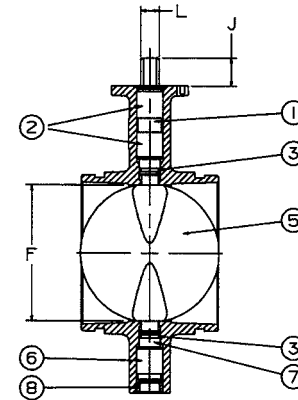
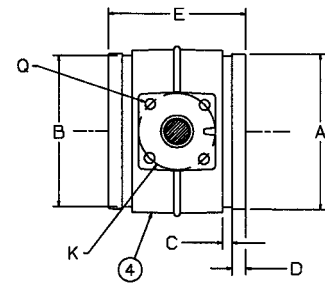

300 PSI Grooved End Butterfly Valves

- polyamide coated ductile iron body • extended neck
- elastomer encapsulated disc • grooved mechanical style
- 12" maximum pressure rating 200 PSI • maximum temperature rating of 200°F • grooved end compatible with IPS pipe

Sizes 2" through 12"

DESIGNED TO MEET MSS SP-67 STANDARD

- NSF/ANSI 61-8 COMMERCIAL HOT 180°F (INCLUDES ANNEX F AND G) AND NSF/ANSI-372



NSF/ANSI 61
NSF/ANSI 372



GD 4765N
w/EPDM Liner

MATERIAL LIST

PART	SPECIFICATION
1. Upper Stem	Stainless Steel ASTM A582 Type 416
2. Upper Bearing	Split Metal
3. O-Ring	EPDM
4. Body	Ductile Iron ASTM A395 w/Polyamide Coating
5. Disc	Ductile Iron ASTM A395 w/EPDM
6. Lower Bearing	Split Metal
7. Lower Stem	Stainless Steel ASTM A582 Type 416
8. Dust Plug	PVC
9. Name Plate	Aluminum

DIMENSIONS — WEIGHTS

Size		A	B	C	D	E	F	G	J
In.	mm.								
2	50	2.38	2.32	.33	.63	3.33	2.42	.46	1.31
2 1/2	65	2.88	2.72	.31	.63	3.85	2.42	.46	1.22
3	80	3.50	3.34	.31	.63	3.85	2.86	.46	1.18
3 O.D.	76.1	3.00	2.84	.31	.63	3.85	2.42	.46	1.22
4	100	4.50	4.33	.38	.63	4.56	3.84	.46	1.24
5	125	5.56	5.39	.38	.63	5.86	4.79	.46	1.24
6	150	6.63	6.45	.38	.63	5.86	5.73	.46	1.29
6 1/2 O.D.	165.1	6.51	6.32	.38	.63	5.86	5.73	.46	1.29
8	200	8.63	8.44	.44	.75	5.26	7.71	.46	1.32
10	250	10.75	10.56	.50	.75	6.29	9.56	.70	1.38
12	300	12.76	12.51	.50	.75	6.52	11.55	.70	1.38

Size		K	L	M	N	P	Q	R	Weight	
In.	mm.								Lbs.	Kg.
2	50	3.25	.50	.37	4.00	3.14	.437	2.89	6.7	3.0
2 1/2	65	3.25	.50	.37	4.19	3.25	.437	3.46	7.5	3.4
3	80	3.25	.50	.37	4.44	3.54	.437	3.97	8.7	3.9
3 O.D.	76.1	3.25	.50	.37	4.19	3.25	.437	3.46	8.7	3.9
4	100	3.25	.66	.50	5.33	4.35	.437	5.03	12.2	5.5
5	125	3.25	.66	.50	5.83	4.84	.437	6.27	17.3	7.8
6	150	3.25	.78	.56	7.11	5.93	.437	7.25	27.4	12.4
6 1/2 O.D.	165.1	3.25	.78	.56	7.11	5.93	.437	7.25	27.4	12.4
8	200	3.25	.78	.56	8.05	6.87	.437	9.25	32.5	14.7
10	250	5.00	1.06	.75	9.86	9.17	.562	11.25	69.6	31.6
12	300	5.00	1.06	.75	10.85	10.17	.562	13.14	88.0	39.9

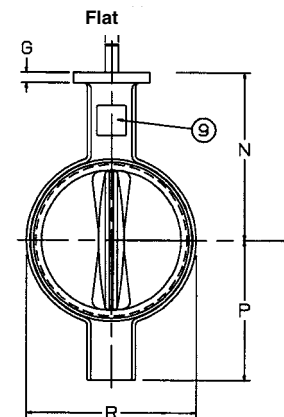
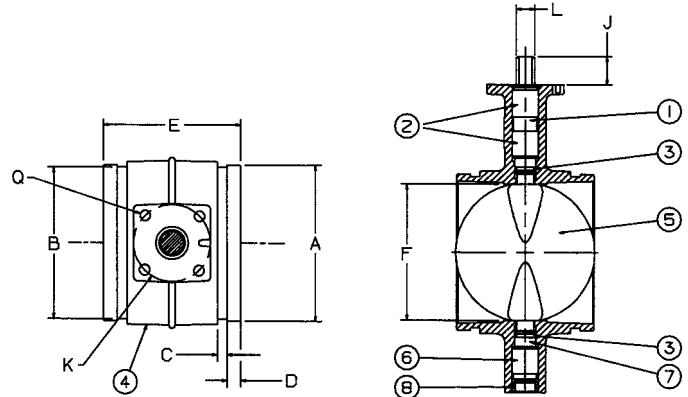

NOT RECOMMENDED
FOR STEAM SERVICE

*Weighted average lead content ≤ 0.25%

300 lb. WWP UL/FM Butterfly Valves

fire protection valve • grooved mechanical style • nylon coated ductile iron body • extended neck • elastomer encapsulated disc • internal supervisory switches standard on -8 version • compatible with IPS pipe

300 PSI/20.7 bar non-shock cold water 2 1/2" - 8"
175 PSI/12.1 bar non-shock cold water 10"

UL/ULC LISTED • FM APPROVED • 2 1/2" - 10" UL LISTED FOR INDOOR AND OUTDOOR SERVICE • CALIFORNIA STATE FIRE MARSHALL LISTING NO. 7770-1243:101 • APPROVED BY THE NEW YORK CITY MEA 9-97-E, VOL.2 WHEN ASSEMBLED WITH APPROPRIATE NYC INDICATOR FLAG



GD-1765-8N
10"
(not shown)

GD-4765-8N*
Grooved
2 1/2" thru 8"

MATERIAL LIST

PART	SPECIFICATION
1. Upper Stem	Stainless Steel ASTM A582 Type 416
2. Upper Bushing	PTFE Bronze Sintered on Steel
3. "O" Ring	EPDM
4. Body	Ductile Iron ASTM A395 with Polyamide Coating
5. Disc	Ductile Iron ASTM A395 with EPDM Encapsulation
6. Lower Bushing	PTFE Bronze Sintered on Steel
7. Lower Stem	Stainless Steel ASTM A582 Type 416
8. Dust Plug	PVC
9. Nameplate	Aluminum
10. Gear Operator	Cast Iron and Steel
11. Indicator Flag	Cast Iron
12. Handwheel	Cast Iron

*-8N version has two factory mounted internal supervisory switches.
-4N version is gear operated only
Uses NIBCO model #TS-4 Switch Kit.
Polyamide coating has NSF certification.

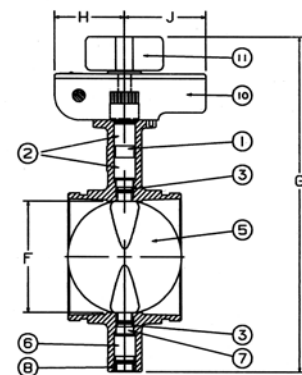
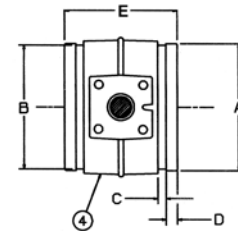

DIMENSIONS—WEIGHTS—QUANTITIES

Size	Dimensions														
	A		B		C		D		E		F		G		H
In. mm.	In. mm.	In. mm.	In. mm.	In. mm.	In. mm.	In. mm.	In. mm.	In. mm.	In. mm.	In. mm.	In. mm.	In. mm.	In. mm.	In. mm.	In. mm.
2 1/2	65	2.88 73	2.72 69	0.31 8	0.63 16	3.85 98	2.42 61	11.94 303	2.91 74						
3.0 D.	76.1	3.00 76	2.84 72	0.31 8	0.63 16	3.85 98	2.42 61	11.94 303	2.91 74						
3	80	3.50 89	3.34 85	0.31 8	0.63 16	3.85 98	2.86 73	12.48 317	2.91 74						
4	100	4.50 114	4.33 110	0.38 10	0.63 16	4.56 116	3.84 98	14.18 360	2.91 74						
5	125	5.56 141	5.39 137	0.38 10	0.63 16	5.86 149	4.79 122	15.17 385	2.91 74						
6	150	6.63 168	6.45 164	0.38 10	0.63 16	5.86 149	5.73 146	17.54 446	2.91 74						
6 1/2 O.D.	165.1	6.51 165	6.32 161	0.38 10	0.63 16	5.86 149	5.73 146	17.54 446	2.91 74						
8	200	8.63 219	8.44 214	0.44 11	0.75 19	5.26 134	7.71 196	19.42 493	2.91 74						
10	250	10.75 273	10.56 268	0.50 13	0.75 19	6.29 160	9.56 243	24.03 610	3.90 99						

Size	Dimensions										Weight							
	J		K		L		M		N		P		Q		R		Lbs.	Kg.
In. mm.	In. mm.	In. mm.	In. mm.	In. mm.	In. mm.	In. mm.	In. mm.	In. mm.	In. mm.	In. mm.	In. mm.	In. mm.	In. mm.	In. mm.	In. mm.	In. mm.		
2 1/2	65	3.54 90	2.13 54	5.82 148	5.67 144	4.19 106	3.25 83	5.9 150	3.46 88	22	10.0							
3.0 D.	76.1	3.54 90	2.13 54	5.82 148	5.67 144	4.19 106	3.25 83	5.9 150	3.46 88	22	10.4							
3	80	3.54 90	2.13 54	5.82 148	5.94 151	4.44 113	3.54 90	5.9 150	3.97 101	23	10.4							
4	100	3.54 90	2.13 54	7.64 194	6.31 173	5.33 135	4.35 110	5.9 150	5.03 128	28	12.7							
5	125	3.54 90	2.13 54	7.64 194	7.32 186	5.83 148	4.84 123	5.9 150	6.27 159	31	14.1							
6	150	3.54 90	2.13 54	7.64 194	8.62 219	7.11 181	5.93 151	5.9 150	7.25 184	41	18.6							
6 1/2 O.D.	165.1	3.54 90	2.13 54	7.64 194	8.62 219	7.11 181	5.93 151	5.9 150	7.25 184	41	18.6							
8	200	3.54 90	2.13 54	7.91 201	9.80 249	8.05 204	6.87 174	9.8 250	9.25 235	53	24.1							
10	250	3.98 101	3.03 77	9.49 241	11.61 295	9.86 250	9.17 233	18.0 457	11.80 300	88	40.0							



300 PSI WWP UL/FM Butterfly Valves

Designed for normally closed position monitoring

fire protection valve • grooved mechanical style • nylon coated ductile iron body • extended neck • elastomer encapsulated disc • factory installed internal monitoring switches • compatible with IPS Pipe

300 PSI/20.7 bar non-shock cold water 2½" - 8"

UL/ULC LISTED** • FM APPROVED** • 2½" - 8" UL LISTED FOR INDOOR AND OUTDOOR SERVICE

Warning: these valves are not to be used between the water source and sprinkler head.



GD-4765-C-8N

MATERIAL LIST

PART	SPECIFICATION
1. Upper Stem	Stainless Steel ASTM A582 Type 416
2. Upper Bushing	PTFE Bronze Sintered on Steel
3. "O" Ring	EPDM
4. Body	Ductile Iron ASTM A395 with Polyamide Coating
5. Disc	Ductile Iron ASTM A395 with EPDM Encapsulation
6. Lower Bushing	PTFE Bronze Sintered on Steel
7. Lower Stem	Stainless Steel ASTM A582 Type 416
8. Dust Plug	PVC
9. Nameplate	Aluminum
10. Gear Operator	Cast Iron and Steel
11. Indicator Flag	Cast Iron
12. Handwheel	Cast Iron

Note: comes with two factory mounted internal supervisory switches. Uses NIBCO model #TS-4 Switch Kit. See page 4 of I & M manual for installation and wiring instructions.

Polyamide coating has NSF certification.

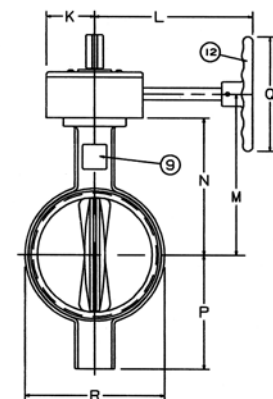
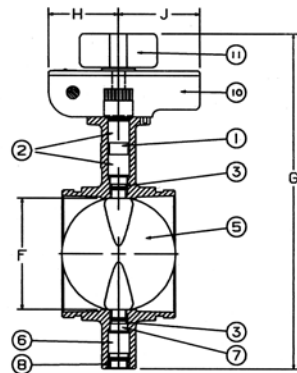
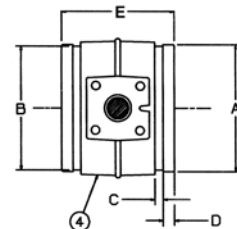

DIMENSIONS—WEIGHTS—QUANTITIES

Size	Dimensions															
	A		B		C		D		E		F		G		H	
In. mm.	In. mm.	In. mm.	In. mm.	In. mm.	In. mm.	In. mm.	In. mm.	In. mm.	In. mm.	In. mm.	In. mm.	In. mm.	In. mm.	In. mm.	In. mm.	
2½	65	2.88 73	2.72 69	0.31 8	0.63 16	3.85 98	2.42 61	11.94 303	2.91 74							
3	80	3.50 89	3.34 85	0.31 8	0.63 16	3.85 98	2.86 73	12.48 317	2.91 74							
4	100	4.50 114	4.33 110	0.38 10	0.63 16	4.56 116	3.84 98	14.18 360	2.91 74							
6	150	6.63 168	6.45 164	0.38 10	0.63 16	5.86 149	5.73 146	17.54 446	2.91 74							
8	200	8.63 219	8.44 214	0.44 11	0.75 19	5.26 134	7.71 196	19.42 493	2.91 74							

Size	Dimensions										Weight						
	J		K		L		M		N		P		Q		R		Lbs.
In. mm.	In. mm.	In. mm.	In. mm.	In. mm.	In. mm.	In. mm.	In. mm.	In. mm.	In. mm.	In. mm.	In. mm.	In. mm.	In. mm.	In. mm.	In. mm.		
2½	65	3.54 90	2.13 54	5.82 148	5.67 144	4.19 106	3.25 83	5.9 150	3.46 88	22	10.0						
3	80	3.54 90	2.13 54	5.82 148	5.94 151	4.44 113	3.54 90	5.9 150	3.97 101	23	10.4						
4	100	3.54 90	2.13 54	7.64 194	6.31 173	5.33 135	4.35 110	5.9 150	5.03 128	28	12.7						
6	150	3.54 90	2.13 54	7.64 194	8.62 219	7.11 181	5.93 151	5.9 150	7.25 184	41	18.6						
8	200	3.54 90	2.13 54	7.91 201	9.80 249	8.05 204	6.87 174	9.8 250	9.25 235	53	24.1						

** Compliance with the Standards for Butterfly Valves for Fire Protection Service, UL 1091 & FM 1112.

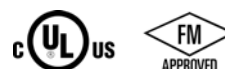

350 lb. WWP UL Butterfly Valves

fire protection valve • grooved mechanical style • nylon coated ductile iron body • extended neck • elastomer encapsulated disc • internal supervisory switches standard on -8 version

350 PSI/24 bar non-shock cold water

UL/ULC LISTED • UL LISTED FOR INDOOR AND OUTDOOR SERVICE
• APPROVED BY NEW YORK CITY MEA 9-97-E VOL. 3 AT 350 PSI NON-SHOCK COLD WATER WHEN ASSEMBLED WITH APPROPRIATE NYC FLAG



GD-6765-8N
Grooved
2½" thru 10"

MATERIAL LIST	
PART	SPECIFICATION
1. Upper Stem	Stainless Steel ASTM A582 Type 416
2. Upper Bushing	PTFE Bronze Sintered on Steel
3. "O" Ring	EPDM
4. Body	Ductile Iron ASTM A395 with Polyamide Coating
5. Disc	Ductile Iron ASTM A395 with EPDM Encapsulation
6. Lower Bushing	PTFE Bronze Sintered on Steel
7. Lower Stem	Stainless Steel ASTM A582 Type 416
8. Dust Plug	PVC
9. Nameplate	Aluminum
10. Gear Operator	Cast Iron and Steel
11. Indicator Flag	Cast Iron
12. Handwheel	Cast Iron

Factory mounted with two internal supervisory switches.
Uses NIBCO model #TS-4 Switch Kit.
Polyamide coating has NSF certification.

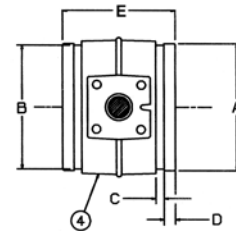

DIMENSIONS—WEIGHTS—QUANTITIES

Size	Dimensions															
	A		B		C		D		E		F		G		H	
In. mm.	In. mm.	In. mm.	In. mm.	In. mm.	In. mm.	In. mm.	In. mm.	In. mm.	In. mm.	In. mm.	In. mm.	In. mm.	In. mm.	In. mm.	In. mm.	
2½	65	2.88 73	2.72 69	0.31 8	0.63 16	3.85 98	2.42 61	11.94 303	2.91 74							
3.0 D.	76.1	3.00 76	2.84 72	0.31 8	0.63 16	3.85 98	2.42 61	11.94 303	2.91 74							
3	80	3.50 89	3.34 85	0.31 8	0.63 16	3.85 98	2.86 73	12.48 317	2.91 74							
4	100	4.50 114	4.33 110	0.38 10	0.63 16	4.56 116	3.84 98	14.18 360	2.91 74							
5	125	5.56 141	5.39 137	0.38 10	0.63 16	5.86 149	4.79 122	15.17 385	2.91 74							
6	150	6.63 168	6.45 164	0.38 10	0.63 16	5.86 149	5.73 146	17.54 446	2.91 74							
6½ O.D.	165.1	6.51 165	6.32 161	0.38 10	0.63 16	5.86 149	5.73 146	17.54 446	2.91 74							
8	200	8.63 219	8.44 214	0.44 11	0.75 19	5.26 134	7.71 196	19.42 493	2.91 74							
10	250	10.75 273	10.56 268	0.50 13	0.75 19	6.29 160	9.56 243	24.03 610	3.90 99							

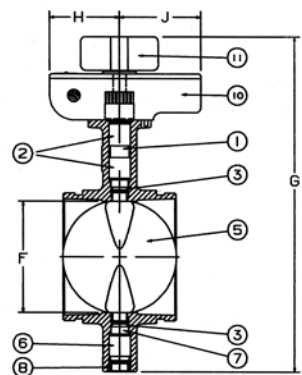

Size	Dimensions									Weight									
	J		K		L		M		N		P		Q		R		Lbs.	Kg.	
In. mm.	In. mm.	In. mm.	In. mm.	In. mm.	In. mm.	In. mm.	In. mm.	In. mm.	In. mm.	In. mm.	In. mm.	In. mm.	In. mm.	In. mm.	In. mm.	In. mm.			
2½	65	3.54 90	2.13 54	5.82 148	5.67 144	4.19 106	3.25 83	5.9 150	3.46 88	22	10.0								
3.0 D.	76.1	3.54 90	2.13 54	5.82 148	5.67 144	4.19 106	3.25 83	5.9 150	3.46 88	22	10.4								
3	80	3.54 90	2.13 54	5.82 148	5.94 151	4.44 113	3.54 90	5.9 150	3.97 101	23	10.4								
4	100	3.54 90	2.13 54	7.64 194	6.31 173	5.33 135	4.35 110	5.9 150	5.03 128	28	12.7								
5	125	3.54 90	2.13 54	7.64 194	7.32 186	5.83 148	4.84 123	5.9 150	6.27 159	31	14.1								
6	150	3.54 90	2.13 54	7.64 194	8.62 219	7.11 181	5.93 151	5.9 150	7.25 184	41	18.6								
6½ O.D.	165.1	3.54 90	2.13 54	7.64 194	8.62 219	7.11 181	5.93 151	5.9 150	7.25 184	41	18.6								
8	200	3.54 90	2.13 54	7.91 201	9.80 249	8.05 204	6.87 174	9.8 250	9.25 235	53	24.1								
10	250	3.98 101	3.03 77	9.49 241	11.61 295	9.86 250	9.17 233	18.0 457	11.80 300	88	40.0								

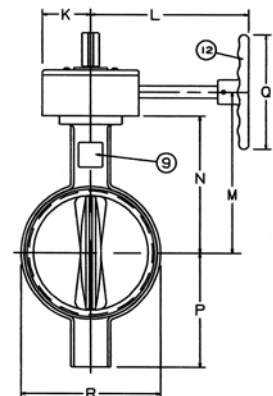

4 Valves in one

FC2000 Series FD5000 Series

Sizes 2"-12"

Your *Best* Valve Replacement Option

NIBCO® flanged butterfly valve dimensionally replaces the:

- Gate Valve
- Ball Valve
- Plug Valve
- Spooled Butterfly Valve

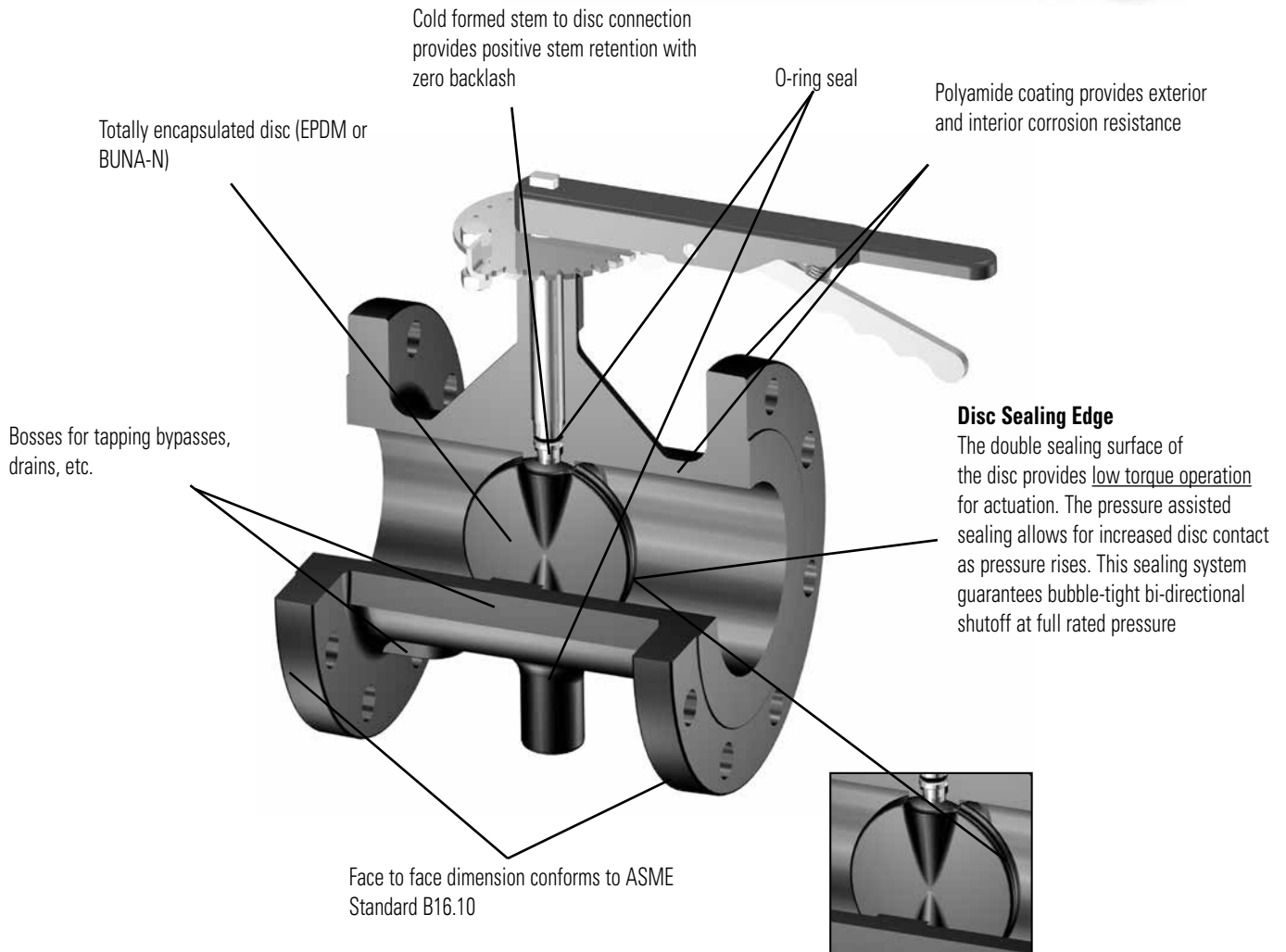

Disc Sealing Edge
The double sealing surface of the disc provides low torque operation for actuation. The pressure assisted sealing allows for increased disc contact as pressure rises. This sealing system guarantees bubble-tight bi-directional shutoff at full rated pressure

Note - polyamide coating maximum temperature 200°F

200 PSI Flanged End Butterfly Valves

polyamide coated cast iron body • extended neck • cold form stem drive
• elastomer encapsulated disc • flanged ends • maximum temperature 200°F with EPDM only • ASME B16.10 face-to-face dimensions

Patent pending

Sizes 2" through 12"

DESIGNED TO MEET MSS SP-67 STANDARD



FC-27*5-0

*Optional disc
EPDM (6)
or BUNA (7)

MATERIAL LIST

PART	SPECIFICATION
1. Upper Stem	Stainless Steel, ASTM A582 Type 416
2. Upper Bushing	PTFE over Porous Bronze, Steel Backed
3. O-Ring	EPDM or BUNA-N
4. Body	Cast Iron ASTM A126 Class B with Polyamide Coating
5. Disc	Ductile Iron ASTM A395 with EPDM or BUNA-N Encapsulation
6. Lower Bushing	PTFE over Porous Bronze, Steel Backed
7. Lower Stem	Stainless Steel, ASTM A582 Type 416
8. Dust Plug	PVC
9. Nameplate	Aluminum

Class 125 flange ends
Polyamide coating has NSF certification

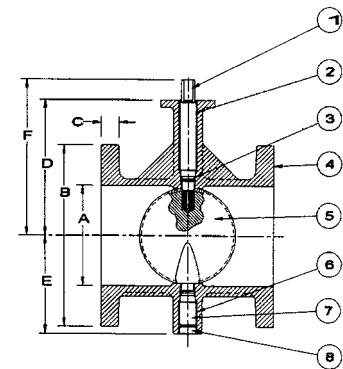

DIMENSIONS — WEIGHTS

Size		A	B	C	D	E	F	G	J
In.	mm.								
2	50	2.11	6.0	0.62	5.69	3.16	6.94	7.00	0.437
2 1/2	65	2.59	7.0	0.69	5.78	3.25	7.03	7.50	0.437
3	80	3.07	7.5	0.75	5.99	3.54	7.24	8.00	0.437
4	100	4.03	9.0	0.94	6.99	4.35	8.24	9.00	0.437
5	125	5.05	10.0	0.94	7.47	4.85	8.72	10.00	0.437
6	150	6.07	11.0	1.00	8.28	5.94	9.53	10.50	0.437
8	200	7.98	13.5	1.12	9.25	6.87	10.50	11.50	0.437
10	250	10.02	16.0	1.19	11.03	9.18	12.28	13.00	0.562
12	300	12.00	19.0	1.25	12.01	10.16	13.26	14.00	0.562

Size		Weight								
In.	mm.	K	L	M	N	P	Q	R	Lbs.	Kg.
2	50	3.25	3.25	0.50	0.37	0.75	4.75	4	16.5	7.5
2 1/2	65	3.25	3.25	0.50	0.37	0.75	5.50	4	24	10.9
3	80	3.25	3.25	0.50	0.37	0.75	6.00	4	28	12.7
4	100	3.25	3.25	0.66	0.50	0.75	7.50	8	44	20.0
5	125	3.25	3.25	0.66	0.50	0.88	8.50	8	53	24.1
6	150	3.25	3.25	0.78	0.56	0.88	9.50	8	65	30.0
8	200	3.25	3.25	0.78	0.56	0.88	11.75	8	94	42.7
10	250	5.00	4.75	1.06	0.75	1.00	14.25	12	155	70.4
12	300	5.00	4.75	1.06	0.75	1.00	17.00	12	214	97.6

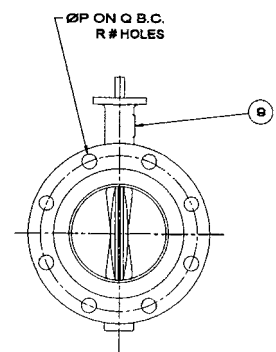
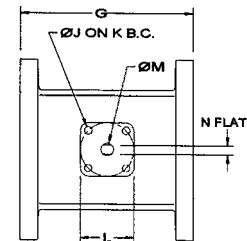

NOT RECOMMENDED
FOR STEAM SERVICE

285 PSI Flanged End Butterfly Valves

polyamide coated ductile iron body • extended neck • cold form stem drive
• elastomer encapsulated disc • flanged ends • maximum temperature 200°F
with EPDM only • ASME B16.10 face-to-face dimensions

Patent pending

Sizes 2" through 12"

DESIGNED TO MEET MSS SP-67 STANDARD



FD-57*5-0

*Optional disc
EPDM (6)
or BUNA (7)

MATERIAL LIST

PART	SPECIFICATION
1. Upper Stem	Stainless Steel, ASTM A582 Type 416
2. Upper Bushing	PTFE over Porous Bronze, Steel Backed
3. "O" Ring	EPDM or BUNA-N
4. Body	Ductile Iron ASTM A536 with Polyamide Coating
5. Disc	Ductile Iron ASTM A395 with EPDM or BUNA-N Encapsulation
6. Lower Bushing	PTFE over Porous Bronze, Steel Backed
7. Lower Stem	Stainless Steel, ASTM A582 Type 416
8. Dust Plug	PVC
9. Nameplate	Aluminum

Class 150 ends are standard. PN10, PN16 available.
Sizes 2" through 8", 285 psi - 10" to 12", 200 psi
Polyamide coating has NSF certification

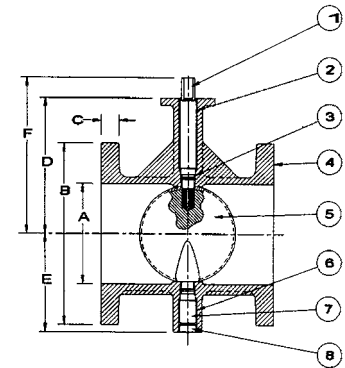

DIMENSIONS — WEIGHTS

Size		A	B	C	D	E	F	G	H
In.	mm.								
2	50	2.11	6.0	0.62	5.69	3.16	6.94	7.00	3.62
2 1/2	65	2.59	7.0	0.69	5.78	3.25	7.03	7.50	4.12
3	80	3.07	7.5	0.75	5.99	3.54	7.24	8.00	5.00
4	100	4.03	9.0	0.94	6.99	4.35	8.24	9.00	6.19
5	125	5.05	10.0	0.94	7.47	4.85	8.72	10.00	7.31
6	150	6.07	11.0	1.00	8.28	5.94	9.53	10.50	8.50
8	200	7.98	13.5	1.12	9.25	6.87	10.50	11.50	10.62
10	250	10.02	16.0	1.19	11.03	9.18	12.28	13.00	12.75
12	300	12.00	19.0	1.25	12.01	10.16	13.26	14.00	15.00

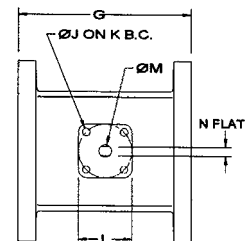

Size		Weight									
In.	mm.	J	K	L	M	N	P	Q	R	Lbs.	Kg.
2	50	0.437	3.25	3.25	0.50	0.37	0.75	4.75	4	16	7.3
2 1/2	65	0.437	3.25	3.25	0.50	0.37	0.75	5.50	4	23	10.4
3	80	0.437	3.25	3.25	0.50	0.37	0.75	6.00	4	27	12.3
4	100	0.437	3.25	3.25	0.66	0.50	0.75	7.50	8	43	19.5
5	125	0.437	3.25	3.25	0.66	0.50	0.88	8.50	8	52	23.6
6	150	0.437	3.25	3.25	0.78	0.56	0.88	9.50	8	65	29.5
8	200	0.437	3.25	3.25	0.78	0.56	0.88	11.75	8	93	42.2
10	250	0.562	5.00	4.75	1.06	0.75	1.00	14.25	12	154	69.9
12	300	0.562	5.00	4.75	1.06	0.75	1.00	17.00	12	210	95.3

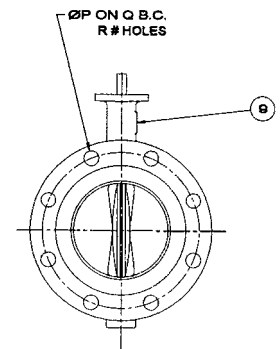

NOT RECOMMENDED
FOR STEAM SERVICE

HIGH PERFORMANCE BUTTERFLY VALVE

LCS6822 (Class 150)

LCS7822 (Class 300)

APPLICATIONS

Ideally suited for commercial, industrial, and mechanical HVAC services. Use in other applications must be approved by the manufacturer

- Heating hot water
- Condenser water
- Glycol
- Chilled water
- Compressed air
- Steam rated - 2" - 12" 150 psi for on/off applications and 50 psi modulating
- Vacuum to 27" Hg
- Chemical process
- Isolation and throttling
- Domestic water

MATERIALS & CONSTRUCTION

- Body constructed of carbon steel
- Stainless steel disc and stem
- Seats of reinforced PTFE for exceptional chemical and heat resistance
- Welded disc pins
- Silicon is not used in the manufacture of this valve

DESIGN CRITERIA

- MSS SP-68 (Design & Testing)
- MSS SP-25 (Markings)
- API-609 Seat pressure/temperature ratings/blow-out proof stem
- ASME/ANSI B16.34A, body pressure/temperature ratings
- ASME/ANSI B16.5 flange dimensions
- ISO 5211, actuator mounting top works
- ANSI Class 150 and Class 300
- Dual offset design

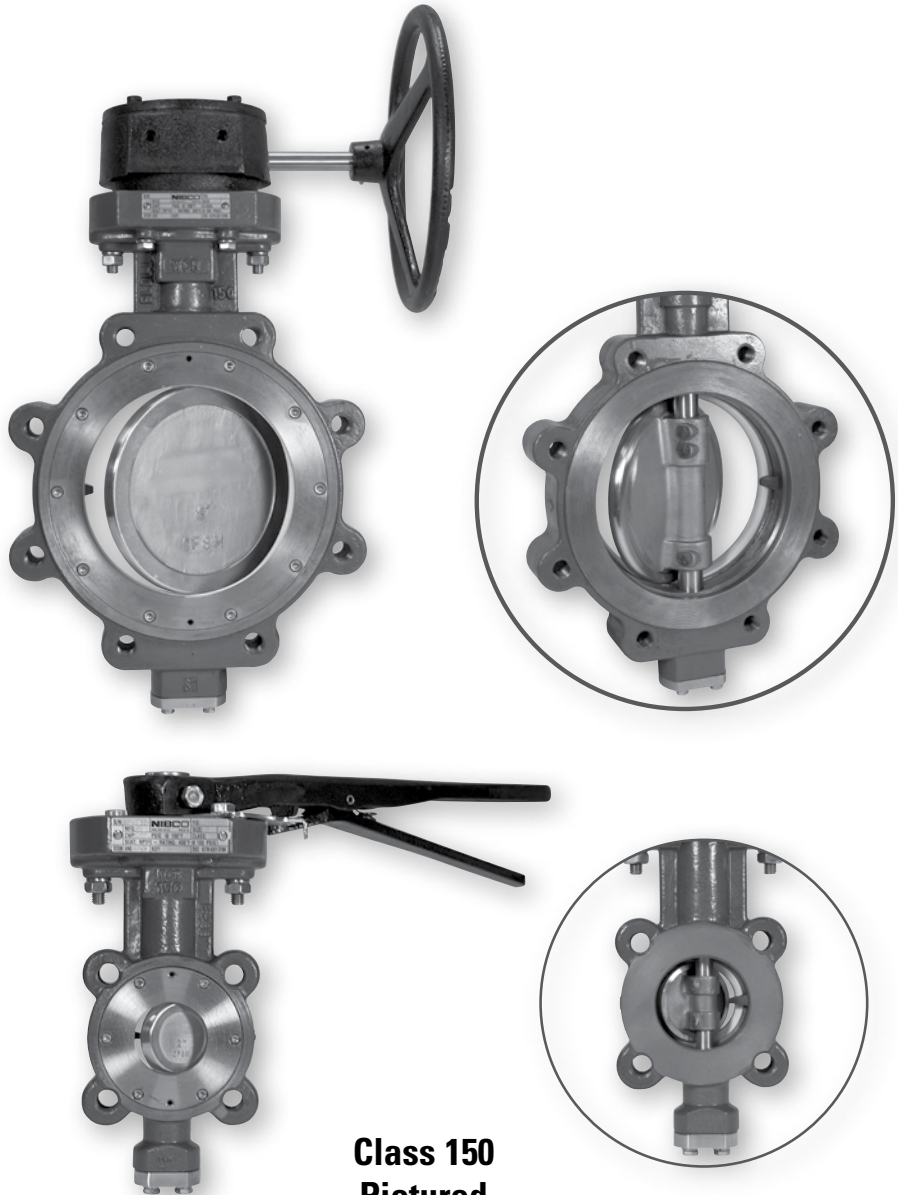

Class 150 Pictured

FEATURES

- Powder coated epoxy finish
- One-piece stem
- Direct mount actuation
- Live loaded adjustable packing with unique flush-mounted packing gland
- Integrally cast disc-stop
- Dual offset design
- Blow-out proof stem
- Uni-directional dead end service (Arrow on body indicates flow direction)
- Maximum operating temperature 400°F at 100 psi
- 100% production tested per MSS SP-68

High Performance Butterfly Valve Series 6822 & 7822

carbon steel body • stainless steel disc and stem • ISO 5211 actuation mounting

CLASS 150 - SIZES 2" THROUGH 30"

CLASS 300 - SIZES 2" THROUGH 24"

ANSI Class 150 & 300

MATERIAL LIST

PART	SPECIFICATION
1. Stem	Stainless Steel UNS ASTM A564 UNS S17400
2. Flange, Gland	Stainless Steel ASTM A351 Grade CF8M
3. Retainer, Stem (4)	Stainless Steel ASTM A276 UNS S31600
4. Gland, Packing	Stainless Steel ASTM A276 UNS S31600
5. Packing (set)	PTFE
6. Retainer, Packing	Stainless Steel ASTM A276 UNS S31600
7. Lockwasher (2)	Stainless Steel Type 304 18-8
8. Nut (2)	Stainless Steel Type 304 18-8
9. Stud (2)	Stainless Steel Type 304 18-8
10. Screw, SHCS	Stainless Steel Type 304 18-8
11. Retainer, Seat	Stainless Steel ASTM A276 UNS S31600
12. Bushing, Upper	Stainless Steel Type 304 PTFE Coated
13. Seat	PTFE 15% Glass Reinforced
14. Disc	Stainless Steel ASTM A351 Grade CF8M
15. Pin, Disc (2)	Stainless Steel ASTM A276 UNS S31600
16. Bushing, Lower	Stainless Steel TYPE 304 PTFE Coated
17. Body	Carbon Steel ASTM A216 GRADE WCB
18. Disc, Spacer	Stainless Steel ASTM A240 UNS S31600
19. Seal, Lower	PTFE
20. Cap, Body	Stainless Steel ASTM A351 Grade CF8M
21. Lockwasher (4)	Stainless Steel Type 304 18-8
22. Screw, Hex (4)	Stainless Steel Type 304 18-8
23. Handle Assembly	Malleable Iron (shown separately)
24. Plate, Throttle	Steel, Plated (shown separately)
25. Screw, Hex	Carbon Steel, Plated (shown separately)
26. Lockwasher	Carbon Steel, Plated (shown separately)
27. Key	Carbon Steel ASTM A108 Grade 1045
28. ID Plate	Stainless Steel

NOTE: for severe steam applications, contact NIBCO Technical Services.

NOTE: if valve is installed opposite the flow arrow for dead end service a downstream flange is required.

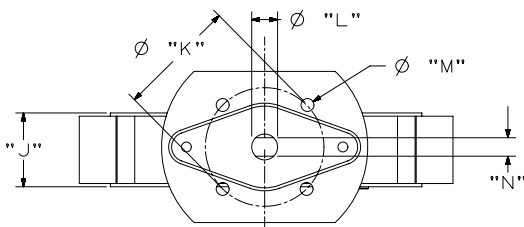
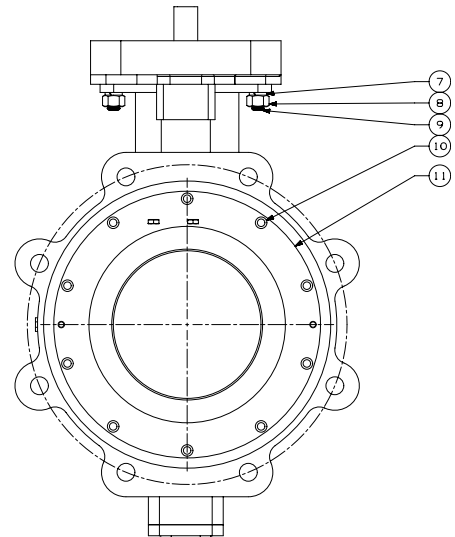
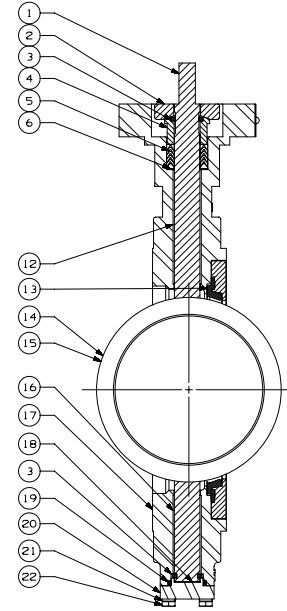

2" - 8" Class 150 Valves
2" - 6" Class 300 Valves

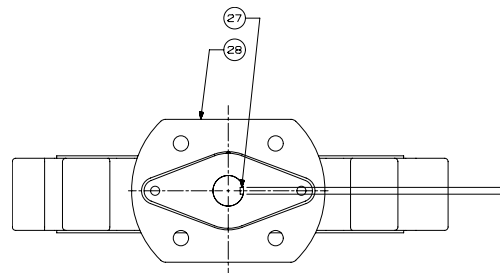

10" - 30" Class 150 Valves
8" - 24" Class 300 Valves

High Performance Butterfly Valve Series 6822

SIZES 2" THROUGH 30"

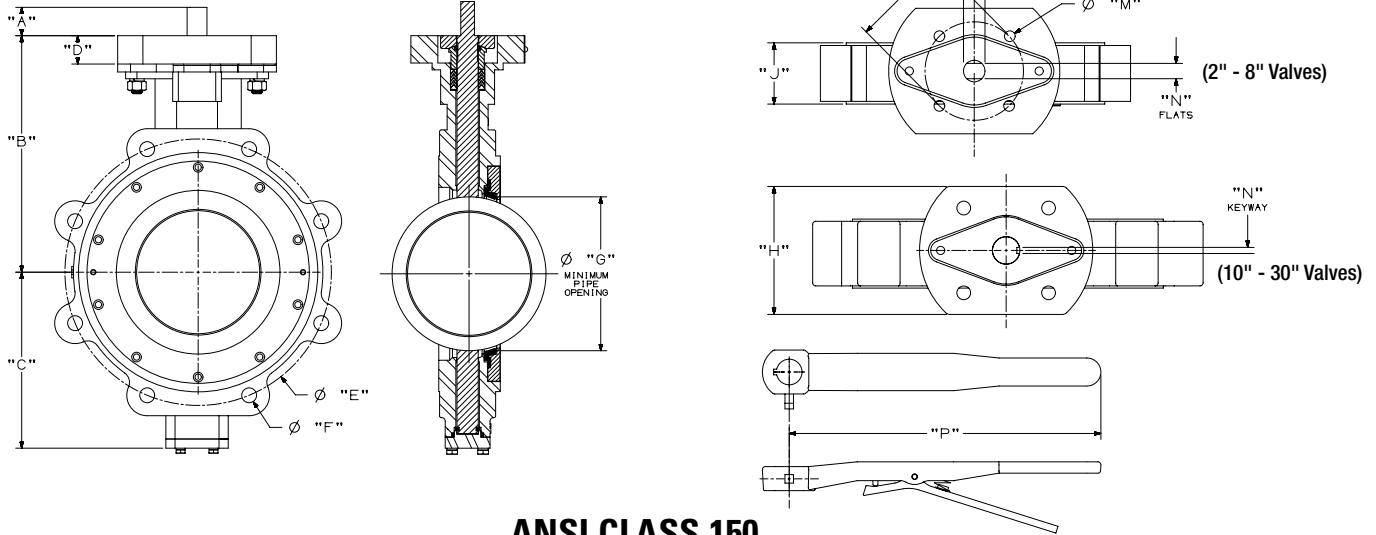

ANSI CLASS 150

DIMENSIONS — WEIGHTS

Valve Size	Gear Operator Mounting	A		B		C		D		E		F		G	
		In.	mm	In.	mm	In.	mm	In.	mm	In.	mm	Threads	In.	mm	
2"	F07	1.25	31.75	5.78	146.8	3.94	100.1	1.25	31.8	4.75	120.65	4 X 5/8"-11 UNC	1.68	42.7	
2½"	F07	1.25	31.75	6.49	164.8	4.06	103.1	1.25	31.8	5.50	139.70	4 X 5/8"-11 UNC	2.24	56.9	
3"	F07	1.25	31.75	6.77	172.0	4.37	111.0	1.25	31.8	6.00	152.40	4 X 5/8"-11 UNC	2.72	69.1	
4"	F07	1.25	31.75	6.98	177.3	4.80	121.9	1.25	31.8	7.50	190.50	8 X 5/8"-11 UNC	3.38	85.9	
5"	F07	1.25	31.75	8.39	213.1	6.38	162.1	1.25	31.8	8.50	215.90	8 X 3/4"-10 UNC	4.48	113.8	
6"	F07	1.25	31.75	8.71	221.2	5.97	151.6	1.25	31.8	9.50	241.30	8 X 3/4"-10 UNC	5.34	135.6	
8"	F10	1.25	31.75	10.43	264.9	7.76	197.1	1.60	40.6	11.75	298.45	8 X 3/4"-10 UNC	7.28	184.9	
10"	F12	2.00	50.80	11.81	300.0	8.61	218.7	1.00	25.4	14.25	361.95	12 X 7/8"-9 UNC	9.13	231.9	
12"	F12	2.00	50.80	12.80	325.1	10.63	270.0	1.00	25.4	17.00	431.80	12 X 7/8"-9 UNC	10.68	271.3	
14"	F12	2.25	57.15	16.03	407.2	11.68	296.7	1.00	25.4	18.75	476.25	12 X 1"-8 UNC	12.14	308.4	
16"	F16	3.00	76.20	16.73	424.9	13.78	350.0	1.88	47.8	21.25	539.75	16 X 1"-8 UNC	13.98	355.1	
18"	F16	3.00	76.20	17.72	450.1	14.76	374.9	1.88	47.8	22.75	577.85	16 X 1-1/8"-8 UN*	16.18	411.0	
**20"	F16	3.00	76.20	18.94	481.1	16.43	417.3	2.00	50.8	25.00	635.00	20 X 1-1/8"-8 UN*	18.13	460.5	
**24"	F16/F25	4.00	101.60	23.23	590.0	19.37	492.0	2.50	63.5	29.50	749.30	20 X 1-1/4"-8 UN*	21.17	537.7	
**30"	F25	5.33	135.38	26.90	683.3	24.24	615.7	3.00	76.2	36.00	914.4	28 X 1-1/4"8 UN*	26.87	682.5	

*SPECIAL PITCH CAP SCREW THREAD REQUIRED PER MSS SP-68 SPECIFICATIONS.

**SHORT SCREWS REQUIRED FOR BLIND TAPPED HOLES NEAREST TO STEM FOR 20" AND LARGER VALVES. SEE INSTALLATION, OPERATION & MAINTENANCE GUIDE II FOR SERIES 6822 & 7822.

Valve Size	H		J		K		L		M		N		P		Valve Wt.		Operating Torque at 285 psi	
	In.	mm	In.	mm	In.	mm	In.	mm	In.	mm	In.	mm	In.	mm	Lbs.	Kg.	In.-Lbs.	N-m
2"	4.15	105.4	1.69	42.93	2.76	70.10	0.500	12.700	0.37	9.40	0.375	9.525	13.75	349.3	12.5	6	290	33
2½"	4.15	105.4	1.84	46.74	2.76	70.10	0.625	15.875	0.37	9.40	0.438	11.125	13.75	349.3	16	7	320	36
3"	4.15	105.4	1.88	47.75	2.76	70.10	0.625	15.875	0.37	9.40	0.438	11.125	13.75	349.3	18	8	350	40
4"	4.15	105.4	2.12	53.85	2.76	70.10	0.625	15.875	0.37	9.40	0.438	11.125	13.75	349.3	31	14	510	58
5"	4.15	105.4	2.25	57.15	2.76	70.10	0.750	19.050	0.37	9.40	0.500	12.700	13.75	349.3	38	17	725	82
6"	4.15	105.4	2.25	57.15	2.76	70.10	0.750	19.050	0.37	9.40	0.500	12.700	13.75	349.3	44	20	845	95
8"	5.12	130.0	2.50	63.50	4.02	102.11	0.875	22.225	0.44	11.18	0.625	15.875	—	—	68	31	1430	162
10"	5.25	133.4	2.83	71.88	4.92	124.97	1.125	28.575	0.56	14.22	1/4" X 1/4"	—	—	104	47	2400	271	
12"	5.25	133.4	3.19	81.03	4.92	124.97	1.125	28.575	0.56	14.22	1/4" X 1/4"	—	—	148	67	3650	412	
14"	5.25	133.4	3.62	91.95	4.92	124.97	1.375	34.925	0.56	14.22	5/16" X 5/16"	—	—	201	91	6000	678	
16"	6.50	165.1	4.00	101.60	6.50	165.10	1.875	47.625	0.81	20.57	3/8" X 1/2"	—	—	309	140	8800	994	
18"	6.50	165.1	4.50	114.30	6.50	165.10	1.875	47.625	0.81	20.57	3/8" X 1/2"	—	—	346	157	11500	1299	
20"	6.50	165.1	5.00	127.00	6.50	165.10	2.125	53.975	0.81	20.57	1/2" X 1/2"	—	—	426	194	16500	1864	
24"	11.02	279.9	6.06	153.92	6.50	165.10	2.555	64.897	0.81	20.57	3/4" X 1/2"	—	—	675	307	24600	2779	
30"	11.25	285.8	7.51	190.75	10.00	254.00	3.142	79.807	0.69	15.53	.866 X .788	—	—	1026	466	37175	4200	

High Performance Butterfly Valve Series 7822

SIZES 2" THROUGH 24"

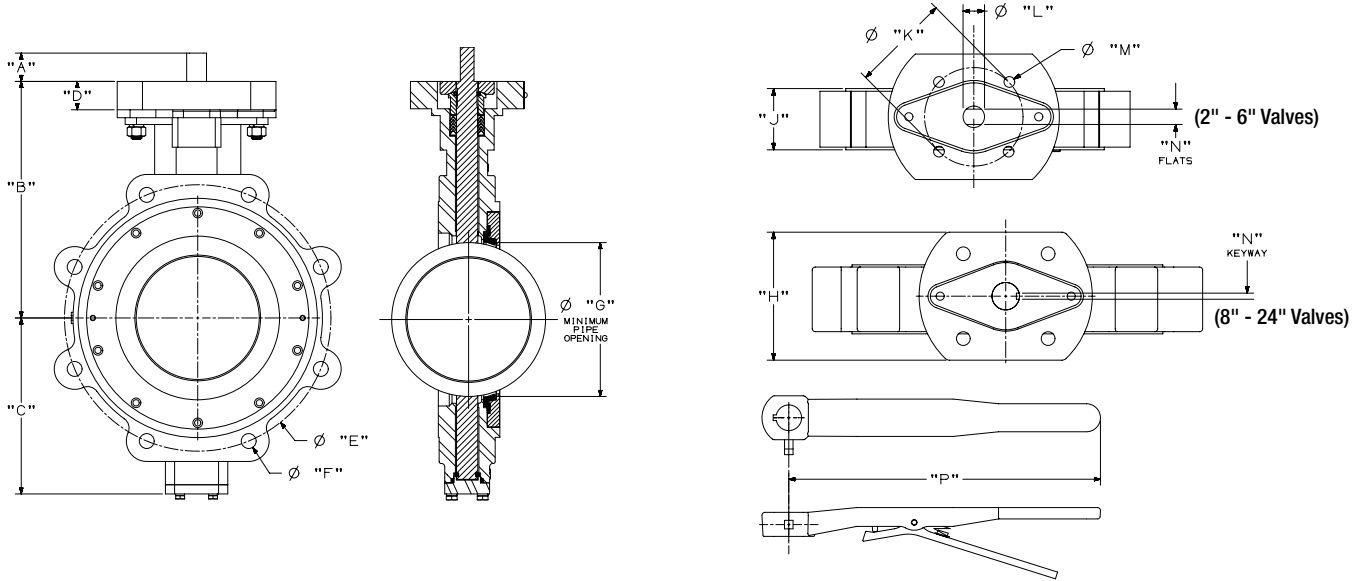

ANSI CLASS 300

DIMENSIONS — WEIGHTS

Valve Size	Gear Operator Mounting	A		B		C		D		E		F		G	
		In.	mm.	In.	mm.	In.	mm.	In.	mm.	In.	mm.	Threads	In.	mm.	
2"	F07	1.25	31.75	5.78	146.8	3.94	100.1	1.25	31.8	5.00	127.00	8 X 5/8"-11 UNC	1.68	42.7	
2½"	F07	1.25	31.75	6.49	164.8	4.06	103.1	1.25	31.8	5.88	149.35	8 X 3/4"-10 UNC	2.24	56.9	
3"	F07	1.25	31.75	6.77	172.0	4.37	111.0	1.25	31.8	6.62	168.15	8 X 3/4"-10 UNC	2.72	69.1	
4"	F07	1.25	31.75	6.98	177.3	4.80	121.9	1.25	31.8	7.88	200.15	8 X 3/4"-10 UNC	3.38	85.9	
5"	F07	1.25	31.75	8.39	213.1	6.38	162.1	1.25	31.8	9.25	234.95	8 X 3/4"-10 UNC	4.42	112.3	
6"	F07	1.25	31.75	9.53	242.1	7.75	196.9	1.25	31.8	10.62	269.75	12 X 3/4"-10 UNC	4.07	103.4	
8"	F10	2.00	50.80	11.42	290.1	8.91	226.3	2.00	50.8	13.00	330.20	12 X 7/8"-9 UNC	7.03	178.6	
10"	F12	2.25	57.15	12.32	312.9	9.88	251.0	1.00	25.4	15.25	387.35	16 X 1"-8 UNC	9.11	231.4	
12"	F12	3.00	76.20	13.90	353.1	11.00	279.4	1.00	25.4	17.75	450.85	16 X 1-1/8"-8 UN*	10.55	268.0	
14"	F16	3.00	76.20	15.95	405.1	12.57	319.3	2.00	50.8	20.25	514.35	20 X 1-1/8"-8 UN*	11.99	304.5	
16"	F16	3.00	76.20	18.31	465.1	15.83	402.1	2.00	50.8	22.50	571.50	20 X 1-1/4"-8 UN*	13.80	350.5	
18"	F25	4.33	109.98	19.29	490.0	16.81	427.0	1.25	31.8	24.75	628.65	24 X 1-1/4"-8 UN*	15.81	401.6	
**20"	F25	4.33	109.98	22.44	570.0	17.72	450.1	1.25	31.8	27.00	685.80	24 X 1-1/4"-8 UN*	17.50	444.5	
**24"	F25	4.33	109.98	24.92	633.0	21.65	549.9	1.25	31.8	32.00	912.80	24 X 1-1/2"-8 UN*	21.50	546.1	

*SPECIAL PITCH CAP SCREW THREAD REQUIRED PER MSS SP-68 SPECIFICATIONS.

**SHORT SCREWS REQUIRED FOR BLIND TAPPED HOLES NEAREST TO STEM FOR 20" AND LARGER VALVES. SEE INSTALLATION, OPERATION & MAINTENANCE GUIDE II FOR SERIES 6822 & 7822.

Valve Size	H		J		K		L		M		N		P		Valve		Operating Torque at 700 psi	
	In.	mm.	In.	mm.	In.	mm.	In.	mm.	In.	mm.	In.	mm.	In.	mm.	Lbs.	Kg.	In.-Lbs.	N-m
2"	4.15	105.4	1.69	42.93	2.76	70.10	0.500	12.700	0.37	9.40	0.375	9.525	13.75	349.3	14	6	390	44
2½"	4.15	105.4	1.84	46.74	2.76	70.10	0.625	15.875	0.37	9.40	0.438	11.125	13.75	349.3	21	10	425	48
3"	4.15	105.4	1.88	47.75	2.76	70.10	0.625	15.875	0.37	9.40	0.438	11.125	13.75	349.3	27	12	450	51
4"	4.15	105.4	2.12	53.85	2.76	70.10	0.625	15.875	0.37	9.40	0.438	11.125	13.75	349.3	49	22	725	82
5"	4.15	105.4	2.31	58.67	2.76	70.10	0.750	19.050	0.37	9.40	0.500	12.700	13.75	349.3	60	27	1000	113
6"	4.15	105.4	2.31	58.67	2.76	70.10	0.750	19.050	0.37	9.40	0.500	12.700	13.75	349.3	71	32	1250	141
8"	5.12	130.0	2.88	73.15	4.02	102.11	1.125	28.575	0.44	11.18	1/4" X 1/4"	—	—	121	55	2025	229	
10"	5.25	133.4	3.25	82.55	4.92	124.97	1.375	34.925	0.56	14.22	5/16" X 5/16"	—	—	143	65	3775	426	
12"	5.25	133.4	3.62	91.95	4.92	124.97	1.625	41.275	0.56	14.22	3/8" X 3/8"	—	—	216	98	5725	647	
14"	6.50	165.1	4.62	117.35	6.50	165.10	1.875	47.625	0.81	20.57	1/2" X 3/8"	—	—	378	172	11500	1299	
16"	6.50	165.1	5.25	133.35	6.50	165.10	1.875	47.625	0.81	20.57	1/2" X 3/8"	—	—	488	222	15338	1733	
18"	11.02	279.9	5.88	149.35	10.0	254.00	2.555	64.897	0.75	19.05	3/4" X 1/2"	—	—	720	327	19516	2205	
20"	11.02	279.9	6.30	160.02	10.0	254.00	2.555	64.897	0.75	19.05	3/4" X 1/2"	—	—	855	389	26022	2940	
24"	11.02	279.9	7.12	180.85	10.0	254.00	2.555	64.897	0.75	19.05	3/4" X 1/2"	—	—	—	—	—	—	

High Performance Butterfly Valve Technical Data

CLASS 150 HPBFV 6800 Series Flow Data

Valv Size	Cv Rating	DISC OPEN - Degrees								
		10°	20°	30°	40°	50°	60°	70°	80°	90°
2"	92	2	6	13	20	30	43	72	81	92
2½"	150	3	11	21	33	50	71	117	132	150
3"	260	5	18	36	57	86	122	203	230	260
4"	460	9	32	64	101	152	216	360	405	460
5"	760	15	53	106	167	251	357	595	670	760
6"	1150	23	81	161	253	380	540	897	1015	1150
8"	2100	42	147	295	462	695	987	1640	1850	2100
10"	3200	64	225	450	705	1056	1505	2496	2816	3200
12"	4700	94	330	660	1035	1551	2210	3666	4136	4700
14"	5800	116	406	815	1276	1915	2726	4525	5105	5800
16"	8000	160	560	1120	1760	2640	3760	6240	7040	8000
18"	10500	210	735	1470	2310	3465	4935	8190	9240	10500
20"	14000	280	980	1960	3080	4620	6580	10920	12320	14000
24"	21000	420	1470	2940	4620	6930	9870	16380	18480	21000
30"		980	2750	4700	7800	11700	17000	23700	29600	33500

CLASS 300 HPBFV 7800 Series Flow Data

Valve Size	Cv Rating	DISC OPEN - Degrees								
		10°	20°	30°	40°	50°	60°	70°	80°	90°
2"	92	2	6	13	20	30	43	72	81	92
2½"	150	3	11	21	33	50	71	117	132	150
3"	260	5	18	36	57	86	122	203	230	260
4"	460	9	32	65	101	152	216	360	405	460
5"	760	15	53	106	167	251	357	595	670	760
6"	1150	23	81	161	253	380	540	987	1015	1150
8"	1900	38	133	266	418	627	895	1485	1675	1900
10"	2800	56	196	392	616	925	1316	2185	2465	2800
12"	4100	82	287	575	905	1355	1930	3200	3610	4100
14"	5500	110	385	770	1210	1815	2585	4290	4840	5500
16"	7600	152	532	1065	1675	2510	3575	5930	6690	7600
18"	9900	198	695	1390	2180	3270	4566	7725	8715	9900
20"	13000	260	910	1820	2860	4290	6110	10140	11440	13000
24"	19500	390	1365	2730	4290	6435	9165	15210	14160	19500

Cv = Flow in U.S. Gallons per minute of 60°F water with a 1 psi pressure drop across valve

Pressure Temperature Seat Rating (RPTFE)

Temperature °F	Class 150	Class 300
	-20	285
0	285	740
50	285	740
100	285	740
150	273	708
200	260	675
250	254	530
300	230	390
350	215	250
400	100	100
450	0	0
500	0	0

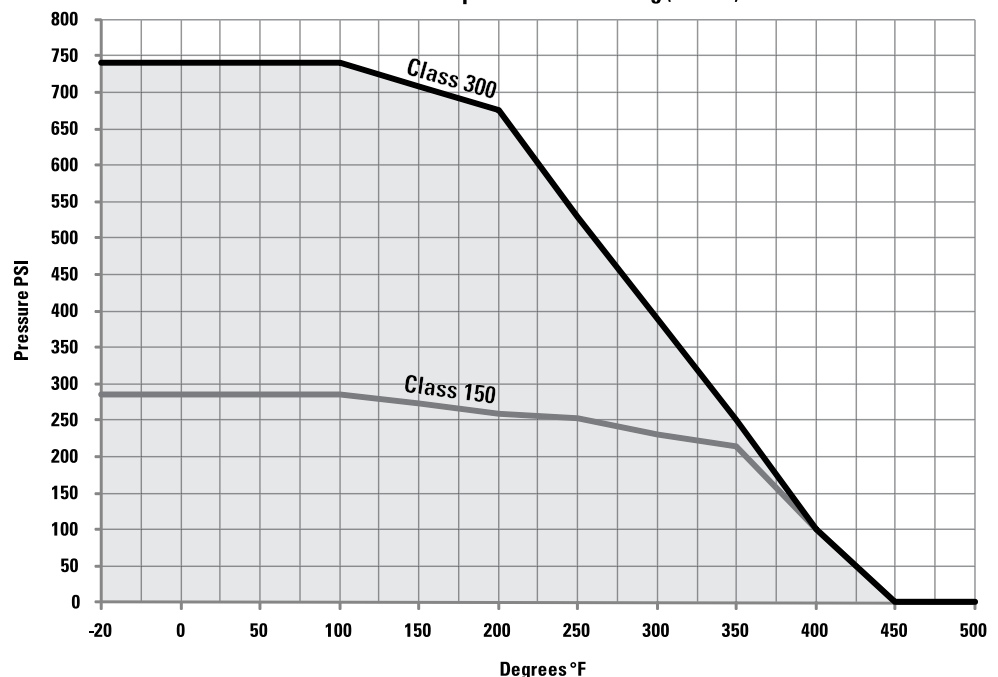

High Performance Butterfly Valve Technical Data

OPERATORS

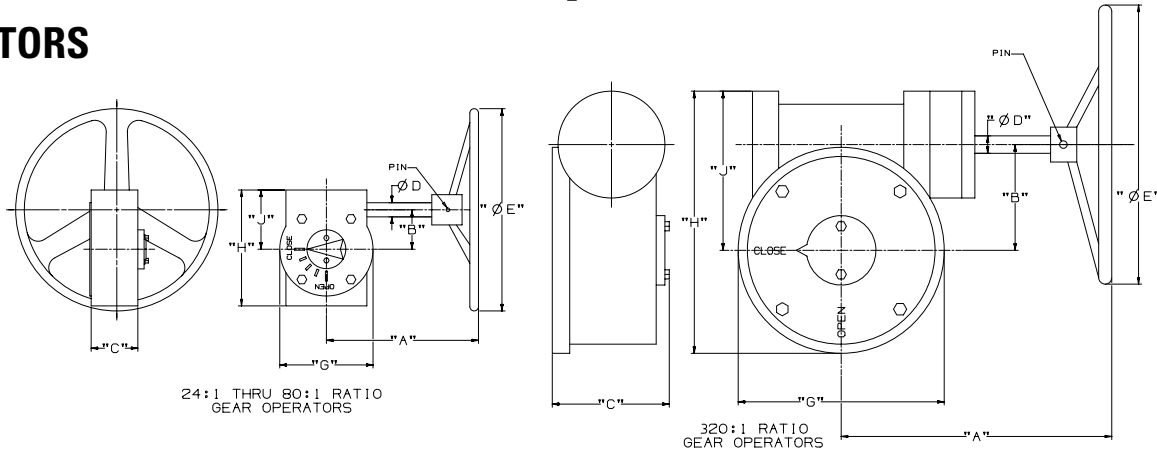

GEAR OPERATOR DIMENSIONS

Valve Size		Gear Operator Figure Number	NIBCO Material Number	Ratio	Gear Operator Efficiency	Gear Operator Mounting	A		B		C		D	
Class 150	Class 300						In.	mm.	In.	mm.	In.	mm.	In.	mm.
2"	2"	GO24:1-1-8	RG70001	24:1	15%	F07	5.77	146.6	1.73	43.9	2.65	67.3	0.625	15.88
2-1/2", 3", 4"	2-1/2", 3", 4"	GO24:1-3-8 W/STSA-4	RG70002	24:1	15%	F07	5.77	146.6	1.73	43.9	2.65	67.3	0.625	15.88
5" 6"	5" 6"	GO24:1-3-8 W/STSA-5	RG70003	24:1	15%	F07	5.77	146.6	1.73	43.9	2.65	67.3	0.625	15.88
8"	—	GO30:1-1-12 W/STSA-6	RG70004	30:1	19%	F10	9.50	241.3	2.50	63.5	3.00	76.2	0.750	19.05
—	8"	GO30:1-1-12	RG70005	30:1	19%	F10	9.50	241.3	2.50	63.5	3.00	76.2	0.750	19.05
10"	—	GO30:1-2-12	RG70006	30:1	19%	F12	9.50	241.3	2.50	63.5	3.00	76.2	0.750	19.05
12"	—	GO50:1-1-16	RG70007	50:1	20%	F12	9.00	228.6	3.00	76.2	3.00	76.2	0.750	19.05
14"	10"	GO50:1-3-16	RG70008	50:1	20%	F12	9.00	228.6	3.00	76.2	3.00	76.2	0.750	19.05
—	12"	GO80:1-2-16	RG70009	80:1	16%	F12	10.75	273.1	4.75	120.7	4.40	111.8	1.000	25.40
16"	14"	GO80:1-1-16	RG70010	80:1	16%	F16	10.75	273.1	4.75	120.7	4.40	111.8	1.000	25.40
18"	—	GO80:1-1-1-20	RG70011	80:1	16%	F16	10.75	273.1	4.75	120.7	4.40	111.8	1.000	25.40
—	16"	GO320:1-3-20	RG70020	320:1	15%	F16	15.51	394.0	6.06	153.9	6.46	164.1	1.190	30.23
20"	—	GO320:1-1-20	RG70012	320:1	15%	F16	15.51	394.0	6.06	153.9	6.46	164.1	1.190	30.23
24"	18" 20"	GO320:1-2-20	RG70013	320:1	15%	F25	15.51	394.0	6.06	153.9	6.46	164.1	1.190	30.23
30"	24"	GO320:1-4-20	RG70021	320:1	15%	F25	15.51	394.0	6.06	153.9	6.46	164.1	1.190	30.23

Valve Size		E		G		H		J		Weight		Mounting Screws	Handwheel Pin Size	Hand Wheel Figure No.
Class 150	Class 300	In.	mm.	In.	mm.	In.	mm.	In.	mm.	Lbs.	Kg			
2"	2"	8	203	4.00	101.6	5.07	128.8	2.90	73.7	12	5.5	5/16"-18 UNC	Ø.190 X 1.63 LONG	RG70014
2-1/2", 3", 4"	2-1/2", 3", 4"	8	203	4.00	101.6	5.07	128.8	2.90	73.7	12	5.5	5/16"-18 UNC	Ø.190 X 1.63 LONG	RG70014
5" 6"	5" 6"	8	203	4.00	101.6	5.07	128.8	2.90	73.7	12	5.5	5/16"-18 UNC	Ø.190 X 1.63 LONG	RG70014
8"	—	12	305	6.00	152.4	6.90	175.3	3.90	99.1	26.5	12	3/8"-16 UNC	Ø.190 X 1.63 LONG	RG70015
—	8"	12	305	6.00	152.4	6.90	175.3	3.90	99.1	26.5	12	3/8"-16 UNC	Ø.190 X 1.63 LONG	RG70015
10"	—	12	305	6.00	152.4	6.90	175.3	3.90	99.1	26.5	12	1/2"-13 UNC	Ø.190 X 1.63 LONG	RG70015
12"	—	16	406	6.70	170.2	7.80	198.1	4.60	116.8	37.5	17	1/2"-13 UNC	Ø.190 X 1.63 LONG	RG70016
14"	10"	16	406	6.70	170.2	7.80	198.1	4.60	116.8	37.5	17	1/2"-13 UNC	Ø.190 X 1.63 LONG	RG70016
—	12"	16	406	10.25	260.4	11.50	292.1	6.25	158.8	72	33	1/2"-13 UNC	Ø.380 X 1.81 LONG	RG70017
16"	14"	16	406	10.25	260.4	11.50	292.1	6.25	158.8	72	33	3/4"-10 UNC	Ø.380 X 1.81 LONG	RG70017
18"	—	20	508	10.25	260.4	11.50	292.1	6.25	158.8	74	34	3/4"-10 UNC	Ø.380 X 2.50 LONG	RG70018
—	16"	20	508	11.81	300.0	17.00	431.8	11.10	281.9	200	91	3/4"-10 UNC	Ø.380 X 2.50 LONG	RG70019
20"	—	20	508	11.81	300.0	17.00	431.8	11.10	281.9	200	91	3/4"-10 UNC	Ø.380 X 2.50 LONG	RG70019
24"	18" 20"	20	508	11.81	300.0	17.00	431.8	11.10	281.9	200	91	5/8"-11 UNC	Ø.380 X 2.50 LONG	RG70019
30"	24"	20	508	11.81	300.0	17.00	431.8	11.10	281.9	200	91	5/8"-11 UNC	Ø.380 X 2.50 LONG	RG70019

LEVER HANDLE

Item	Description	Material
23	Handle Assembly	Malleable Iron
24	Plate, Throttle	Steel, Plated
25	Screw, Hex	Carbon Steel, Plated
26	Lockwasher	Carbon Steel, Plated

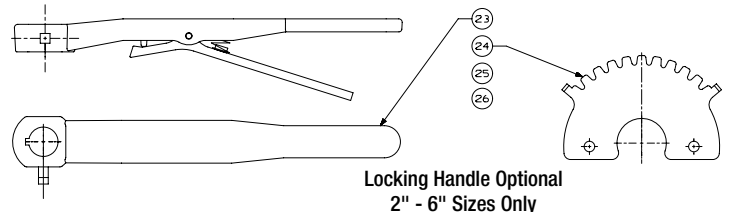

High Performance Butterfly Valve Technical Data

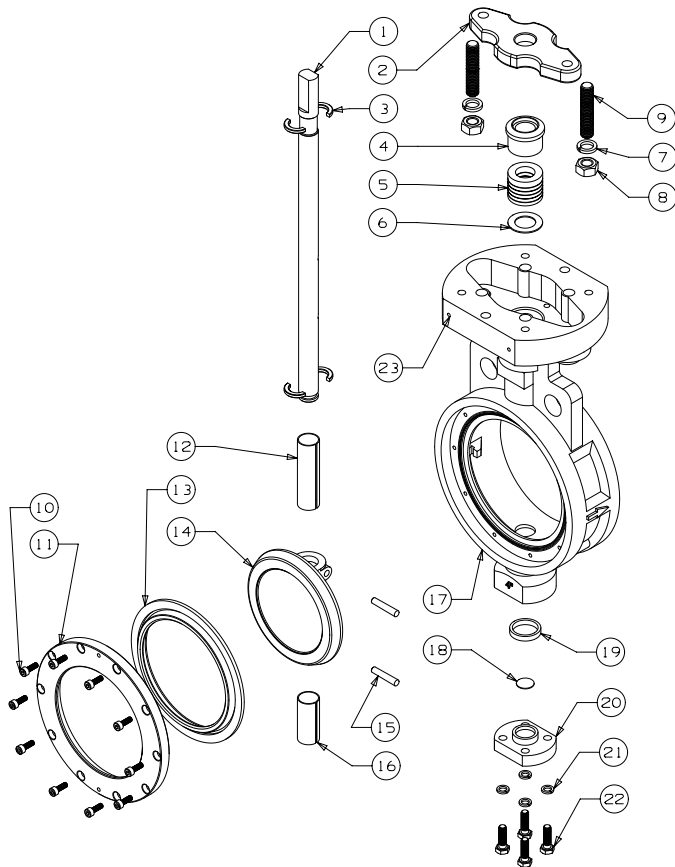

MATERIAL LIST

PART	SPECIFICATION
1. Stem	Stainless Steel UNS ASTM A564 UNS S17400
2. Flange, Gland	Stainless Steel ASTM A351 Grade CF8M
3. Retainer, Stem (2)	Stainless Steel ASTM A276 UNS S31600
4. Gland, Packing	Stainless Steel ASTM A276 UNS S31600
5. Packing	PTFE
6. Retainer, Packing	Stainless Steel ASTM A276 UNS S31600
7. Lockwasher (2)	Stainless Steel Type 304 18-8
8. Nut (2)	Stainless Steel Type 304 18-8
9. Stud (2)	Stainless Steel Type 304 18-8
10. Screw, SHCS	Stainless Steel Type 304 18-8
11. Retainer, Seat	Stainless Steel ASTM A276 UNS S31600
12. Bushing, Upper	Stainless Steel Type 304 PTFE Coated
13. Seat	PTFE 15% Glass Reinforced
14. Disc	Stainless Steel ASTM A351 Grade CF8M
15. Pin, Disc (2)	Stainless Steel ASTM A276 UNS S31600
16. Bushing, Lower	Stainless Steel Type 304 PTFE Coated
17. Body	Carbon Steel ASTM A216 Grade WCB
18. Disc, Spacer	Stainless Steel ASTM A240 UNS S31600
19. Seal, Lower	PTFE
20. Cap, Body	Stainless Steel ASTM A351 Grade CF8M
21. Lockwasher (4)	Stainless Steel Type 304 18-8
22. Screw, Hex (4)	Stainless Steel Type 304 18-8

Options and Accessories Index

Operators	Page
Lever-Lock.....	43
Gear.....	44
Stem Extensions, Silicone Free Issue.....	45

Lever-Lock Operator (Standard) LD/WD2000/3000/5022

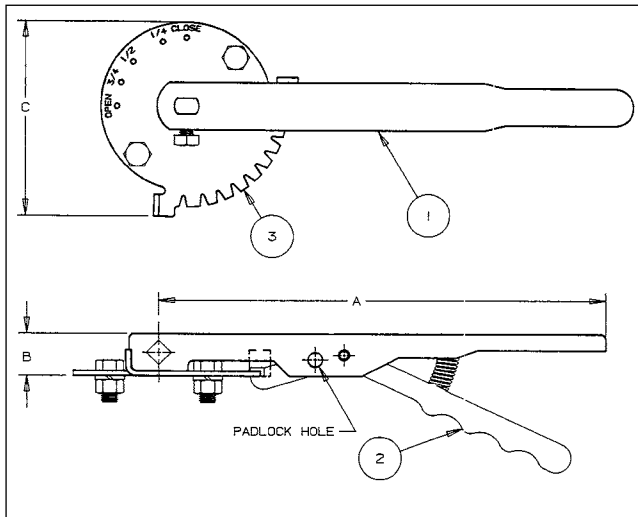

The lever-lock handle and throttling plate provide throttling notches every 10° for excellent manual control in balancing up to 90° or shut off service. The valve may be padlocked in any one of the positions including opened or closed by virtue of a locking hole located in the handle and lever.

Position-Lock Operator (Optional) LD/WD2000/3000/5022

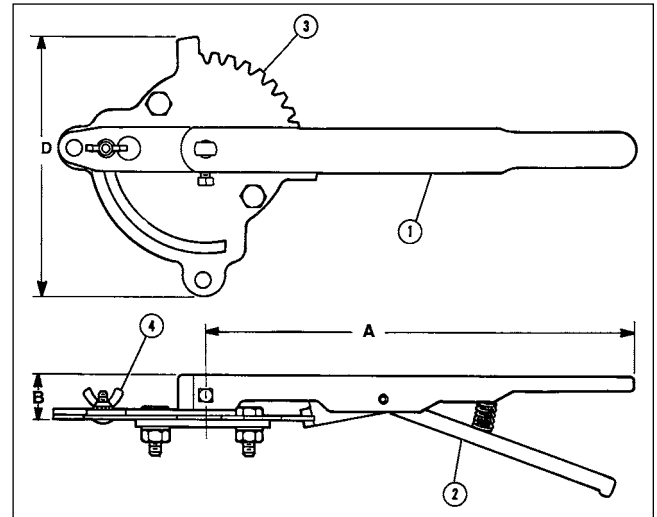

The position-lock can be used to set the valve in any position or as a memory stop so the valve may be reopened to the previous position. The valve may be padlocked in full open or full closed position.

Ordering: Sold as a field retrofitable kit only.

MATERIAL LIST

PART	SPECIFICATION
1. Handle	Polymer Coated Iron
2. Lever-Lock	Zinc Plated Steel
3. Throttle Plate	Zinc Plated Steel

DIMENSIONS AND TORQUE OUTPUT

LD/WD Valve Size	FC/FD GD Valve Size	Lever (STD)	Throttle Plate (STD)	Throttle Plate/ Infinite Pos. Kit	Dimensions				Torque Rated Output in Inch-Pounds	
					A	B	C	D	At 60 pounds Pull	At 100 pounds Pull
2"		T115106PP	T115138PP	T114840FG	10 1/2	1	4 5/8	6 3/16	540 In-Lbs.	900 In-Lbs.
2 1/2" - 3"	2 1/2", 3"	T115107PP	T115138PP	T114841FG	10 1/2	1	4 5/8	6 3/16	540 In-Lbs.	900 In-Lbs.
4"		T115108PP	T115138PP	T114842FG	10 1/2	1	4 5/8	6 3/16	540 In-Lbs.	900 In-Lbs.
	4" - 5"	T118446PP	T115138PP	T114843FG	10 1/2	1	4 5/8	6 3/16	540 In-Lbs.	900 In-Lbs.
5" - 6"		T115109PP	T115138PP	T114843FG	13 3/4	1	4 5/8	6 3/16	735 In-Lbs.	1225 In-Lbs.
8"	6"	T115110PP	T115138PP	T114844FG	13 3/4	1	4 5/8	6 3/16	735 In-Lbs.	1225 In-Lbs.

*Not recommended for 8", 10" and 12" valves

DIMENSIONS AND TORQUE OUTPUT

LCS 6822 Class 150	LCS 7822 Class 300	LEVER	A	B	C & D	@ 60 LBS. PULL	@ 100 LBS. PULL
2"	2"	RG70031 & RG70034 Bushing	13.75"	1.25"	N/A	735 In-Lbs.	1225 In-Lbs.
2 1/2" - 4"	2 1/2" - 4"	RG70032	13.75"	1.25"	N/A	735 In-Lbs.	1225 In-Lbs.
5" - 6"	5" - 6"	RG70033	13.75"	1.25"	N/A	735 In-Lbs.	1225 In-Lbs.

Butterfly Valves

Options and Accessories

Gear operator options and accessories (2" through 12" 2000/3000/5022 Series commercial valves).

2" Square Operating Nut

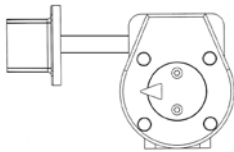

Memory Stop

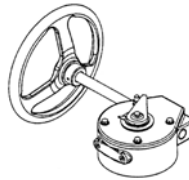

Flag Indicator

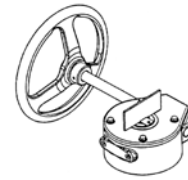

Cast Iron Gear Operator

The NIBCO® butterfly valve can be provided with heavy-duty operator and indicator. Recommended for valves 8" and larger, for trouble-free operation in all moisture and weather conditions (not submersible). Operator is a self-locking worm gear type. **Equipped with adjustable stops at open and shut positions.** Ordering: Specify by adding (-5) to Fig. No., i.e., WD2000-5. Babbit Sprocket may be added to handwheel. See below for sizing information. Available options: Memory Stop Gear Operator Kit, 2" Square Operating Nut, Flag Indicator and Handwheel for GO.

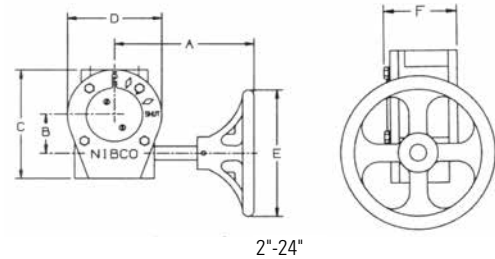

2"-24"

GEAR OPERATOR DETAIL FOR SIZES 2" TO 24" (LCS6822 & LCS7822)*										GEAR OPERATOR ACCESSORIES & REPLACEMENT PARTS			
LCS6822 CL 150 HPBFV	LCS7822 CL 300 HPBFV	GEAR OPERATOR NUMBER	RATIO	GEAR OP WEIGHT	DIMENSIONS (INCHES)						STEM ADAPTER BUSHING	SPROCKET RIM MODEL	REPLACEMENT HANDWHEEL
					A	B	C	D	E	F			
2"	2"	RG70001	24:1	12	5.77	1.73	5.07	4.00	8.00	2.65	DIRECT	#2	RG70014
2½", 3", 4"	2½", 3", 4"	RG70002	24:1	12	5.77	1.73	5.07	4.00	8.00	2.65	RG70022	#2	RG70014
5", 6"	5", 6"	RG70003	24:1	12	5.77	1.73	5.07	4.00	8.00	2.65	RG70023	#2	RG70014
8"	-	RG70004	30:1	26	9.50	2.50	6.90	6.00	12.00	3.00	RG70024	#2½	RG70015
-	8"	RG70005	30:1	26	9.50	2.50	6.90	6.00	12.00	3.00	RG70025	#2½	RG70015
10"	-	RG70006	30:1	26	9.50	2.50	6.90	6.00	12.00	3.00	RG70025	#2½	RG70015
-	10"	RG70008	50:1	37	9.00	3.00	7.80	6.70	16.00	3.00	RG70026	#3	RG70016
12"	-	RG70007	50:1	37	9.00	3.00	7.80	6.70	16.00	3.00	RG70025	#3	RG70016
-	12"	RG70009	80:1	72	10.75	4.75	11.50	10.25	16.00	4.40	RG70027	#3	RG70017
14"	-	RG70008	50:1	37	9.00	3.00	7.80	6.70	16.00	3.00	RG70026	#3	RG70016
16"	-	RG70010	80:1	72	10.75	4.75	11.50	10.25	16.00	4.40	RG70028	#3	RG70017
18"	-	RG70011	80:1	74	10.75	4.75	11.50	10.25	20.00	4.40	RG70028	#4	RG70018
20"	-	RG70012	320:1	200	15.51	6.06	17.00	11.81	20.00	6.46	RG70029	#4	RG70019
24"	-	RG70013	320:1	200	15.51	6.06	17.00	11.81	20.00	6.46	RG70030	#4	RG70019

* No square operating nuts, flag indicators, or memory stop kits are available for LCS6822 and LCS7822 butterfly valves.

GEAR OPERATOR DETAIL FOR SIZES 2" TO 48" (1000/2000/3000/5022)										GEAR OPERATOR ACCESSORIES & REPLACEMENT PARTS						
LD / WD VALVE SIZE	FC / FD / GD VALVE SIZE	GEAR OPERATOR NUMBER	RATIO	GEAR OP WEIGHT	DIMENSIONS (INCHES)						STEM ADAPTER BUSHING	SPROCKET RIM MODEL	SQUARE OPERATING NUT	FLAG INDICATOR	MEMORY STOP KIT	REPLACEMENT HANDWHEEL
					A	B	C	D	E	F						
2"	-	T117118PP	24:1	10	7.64	1.77	5.04	4.24	5.91	2.79	T046652PP	#1½	T117792FC	T116682PP	T026196PP	T117122PP
2½"- 3"	2"-2½"-3"	T117118PP	24:1	10	7.64	1.77	5.04	4.24	5.91	2.79	T046653PP	#1½	T117792FC	T116682PP	T026196PP	T117122PP
4"	-	T117118PP	24:1	10	7.64	1.77	5.04	4.24	5.91	2.79	T046654PP	#1½	T117792FC	T116682PP	T026196PP	T117122PP
5"- 6"	4"- 5" - 6"	T117118PP	24:1	10	7.64	1.77	5.04	4.24	5.91	2.79	T046655PP	#1½	T117792FC	T116682PP	T026196PP	T117122PP
8"	8"	T117119PP	24:1	14	9.53	1.77	5.04	4.24	9.84	2.79	T046656PP	#2½	T117792FC	T116682PP	T026196PP	T117123PP
10"	-	T117120PP	30:1	23	11.54	2.48	6.93	6.06	9.84	3.26	-	#2½	T117793FC	T116682PP	T026197PP	T117124PP
12"	10" - 12"	T117121PP	30:1	23	11.54	2.48	6.93	6.06	9.84	3.26	-	#2½	T117793FC	T116682PP	T026197PP	T117124PP
14"	-	T116697PP	50:1	26	12.87	3.08	7.48	6.28	11.81	3.26	-	#2½	T117793FC	T116682PP	T026198PP	T117169PP
16"	-	T026150PP	80:1	58	13.58	4.72	10.24	9.84	11.81	4.27	-	#2½	T118099FC	T116682PP	T026199PP	T026131PP
18"	-	T026151PP	80:1	57	15.04	4.72	10.24	9.84	15.75	4.27	-	#3½	T118099FC	T116682PP	T026199PP	T026142PP
20"	-	T026211PP	291:1	90	18.11	4.13	11.42	9.84	11.81	5.24	-	#2½	T118099FC	T116682PP	T026199PP	T026131PP
24"	-	T026212PP	291:1	90	18.11	4.13	11.42	9.84	11.81	5.24	-	#2½	T118099FC	T116682PP	T026199PP	T026131PP
30"	-	-	540:1	174	13.23	5.98	15.16	11.81	15.75	6.54	-	#3½	-	-	-	T117836PP
36"	-	-	648:1	332	15.71	8.46	20.40	17.17	15.75	7.83	-	#3½	-	-	-	T117836PP
42"	-	-	800:1	510	17.17	14.21	21.02	19.69	17.72	11.85	-	#3½	-	-	-	T117837PP
48"	-	-	800:1	510	17.17	14.21	21.02	19.69	17.72	11.85	-	#3½	-	-	-	T117837PP

Notes:

1. Gear operator comes with handwheel. Larger sizes come with handwheel unattached. Pin is taped to handwheel.
2. Stem adapter bushing must be ordered separately when needed for smaller size valves.
3. All other accessories must be ordered separately. (Sprocket rim, square operator nut, flag indicator & memory stop kit)

Butterfly Valves Options and Accessories

Stem Extensions

Stem extensions can be furnished to permit remote operation of butterfly valves in any required length. The top flange of an extension stem, plug shaft diameter, and distance across flats on plug shaft are the same size as the valve selected. This allows interchangeability of gear operators, actuators, and adapter bushings from valve mounting flange to extension stem top flange. When ordering, specify valve size, figure number, and the exact distance from the valve flange to the top of extension flange (customer-specified length shown at right). Stem extensions are available in lengths up to 10 feet. For stem extensions in excess of 10 feet consult factory.

See NIBCO Fire Protection catalog for wall post and ground post information.

Some High Performance Valves will require stem extensions for adequate chain clearance. Contact NIBCO Tech Services.

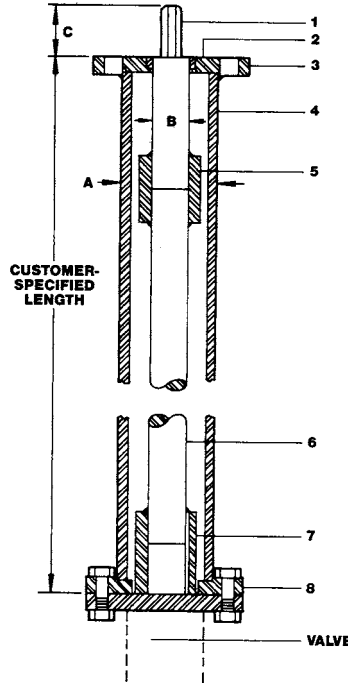

MATERIAL LIST

PART	SPECIFICATION
1. Plug	Steel
2. Top Flange Bushing	Bronze
3. Top Flange	Steel
4. Housing (Steel Pipe)	Steel
5. Plug and Rod Coupling	Steel
6. Rod	Steel
7. Rod and Stem Coupling	Steel
8. Bottom Flange	Steel

DIMENSIONS

SIZE	A	B	C
2"-12"	2.88	1.125	1.12
14"-24" consult NIBCO Technical Services			

NOTE: extension length limited by "B" dimension

Adjustable Sprocket Rim

The Babbitt Adjustable Sprocket Rim will provide for remote operation of butterfly valves in high, normally out-of-reach locations. When ordering specify either the sprocket and chain number or the NIBCO valve figure number and size. The chain length must also be specified. (Chain length is determined by Height x 2 + 2 ft.)

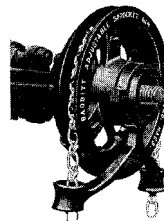

Sprocket Rim Retaining Harness

Babbitt Adjustable Sprocket Rims installed in overhead locations may require a secondary retention harness. It is the responsibility of the installer to determine need for such devices. For those locations use The Babbitt Safety Wheel Cap Kit. The kit contains a ductile iron cap, four stainless steel clamps, a stainless steel cable, and screws to secure the sprocket and hand wheel to a nearby pipe or structural member.



DIMENSIONS - SPECIFICATIONS

Size No.	Dia. of Sprocket Wheel in Inches	Weight in Lbs.	Dia. of HDWL Rim Will Fit	Chain Size No.	Chain Weight per 100' in Lbs.	Butterfly Valve Size
1	5 7/8	4	4 1/8 to 5 7/8	1/0	17 1/2	—
1 1/2	7 1/2	5	6 to 7 1/2	1/0	17 1/2	2-6"
2	9	8	7 3/4 to 9	1/0	17 1/2	—
2 1/2	12 1/2	15	9 1/2 to 12 1/2	4/0	30	8-16", 20", 24"
3	15 1/2	21	12 3/4 to 15 1/2	4/0	30	—
3 1/2	19	25	15 3/4 to 19	4/0	30	18", 30" - 48"
4	22	34	19 1/4 to 22	5/0	35	—

Size No.	Harness Kit	Chain Masterlink	Chain No.
1	RG00SH01	RG00ML1	RG00280
1.5			
2	RG00SH25	RG00ML25	RG00480
2.5			
3			
3.5	RG00SH35	RG00ML4	RG00630
4			

No Silicone Used - Silicone Free Issue

All butterfly valves may incorporate the use of silicone in either grease or aerosol form during the assembly. LD/WD/GD series butterfly valves can be special ordered as "Assemble-Dry" without test. These valves will not be assembled using silicon in the form of grease or aerosol spray.

Note: Even though provisions are made to assemble valves and not incorporate the use of silicone lubricants, the potential for it to be present as air-borne particles prevents us from certifying that our valves are 100% silicone free

Engineering Data Index



	Page
Specifications.....	47
Flow Data.....	48-49
Property of Materials.....	50-53

Technical Information — Butterfly Valves

Dimensional Requirements of Flange/Pipe Connections.....	54
Installation Guide.....	55
Capscrew & Bolt Data.....	55
Gear Operator Installation.....	56-57
Resilient Liner Materials.....	58
Metals Used in Valves & Fittings.....	59
Torque Data.....	60
Actuation Data Sheet.....	61

Specifications

NIBCO® butterfly valves are designed and manufactured to give maximum performance on recommended service at the lowest possible initial and upkeep cost. They are designed to meet standards, codes, and/or specifications, as noted.

American Petroleum Institute

API-609 DESIGN

Manufacturers Standardization Society of the Valve and Fitting Industry, Inc.

MSS SP-25, MSS SP-67 (shell test performed upon request), MSS SP-68

United States Coast Guard — CG190

 Now called "CIMDTINST — M16714.3"

"Equipment list"

"Items approved, certified or accepted under Marine Inspection and Navigation Laws"

NIBCO valves, fittings and flanges are listed in this document.

Code of Federal Regulations Title 46 Shipping Parts 41 to 69

The Code of Federal Regulations is a codification of the general and permanent rules published in the Federal Regulations by the Executive Departments and Agencies of the Federal Government.

This regulation is constantly revised to reference the latest ANSI, ASTM & MSS Standards _____.

NIBCO 2000 and 3000 services have been designated as suitable for Category A service.

NAVY — APL, CID, NSN

"Department of the Navy"

"Navy Ships Parts Control Center"

Mechanicsburg, PA

The Department of the Navy, when using standard commodity type valves, assigns APL-CID numbers to each individual valve manufactured by a company. Valves of the same figure number, but of different size get different CID numbers.

The (APL) Allowance Parts List, (CID) Code Identification Numbers and (NSN) National Stock Numbers are used by the Navy in the Parts Control Center to order replacement valves or parts of valves that are installed on board United States Navy vessels.

When a Navy vessel is being built, the shipyard doing the construction must apply to the Parts Control Center for CID numbers for all valves before the Navy will accept delivery of the vessel.

On many NIBCO valves, the CID and NSN numbers have been assigned. Consult NIBCO for more information.

American Bureau of Shipping — Rules for Building

The American Bureau of Shipping states in Article 36.15.1; All valves are to be constructed and tested in accordance with a recognized standard, such as ANSI, MSS or other, acceptable to the Bureau. They are to bear the trademark of the manufacturer legibly stamped or cast on the exterior of the valve, as well as the pressure rating class for which the manufacturer guarantees the valve will meet the requirements of the standards.

The following NIBCO butterfly valves are manufactured in facilities approved by ABS for marine service: LD or WD 2000 and 3000 series.

ABS Certificate No.: 00N09621-X Manufacturers Federal Code: NIBCO — 12168

Lloyd's Register of Shipping

NIBCO is an approved manufacturer of grey and ductile iron butterfly valves.

Det Norske Veritas

NIBCO® DI Butterfly valves are in compliance with DNV Rules for classification of ships and mobile offshore units. DNV standards for Certification 2.09 No. 101. approved for fresh water, sea water, sanitary water, water ballast, cargo oil transfer and bilge lines

Sample Butterfly Valve Specification

Line Control Valves 2" or larger

Butterfly Valves: Valve shall be full lug or wafer body style. Valves designed to comply with MSS SP-67 Standard. The valves shall be rated at least 200 PSI (2" - 12") and 150 PSI (14" - 48") bi-directional differential pressure. **Body** to have 2" extended neck for insulation and **shock resistant ductile iron**. Valves to have aluminum bronze disc and **molded in or cartridge seat** of EPDM rubber. Stem shall be 400 series stainless steel. Top and bottom stem bushings of dissimilar material are required with a positive stem retention mechanism. Sizes 2" - 6" shall be lever operated with a 10 position throttling plate; sizes 8" and larger shall be gear operated. **Lug style valves shall be capable of providing bi-directional "Dead End Service" minimally at 200 PSI (2-12"), 150 PSI (14"-24"), 100 PSI (30"-48") without the need for down stream flange.**

Acceptable valves:

NIBCO LD-2000 (2" - 12"), LD-1000 (14" - 48")

Flow Data

C_v Values for Valves

Liquid Flow:

$$Q = C_v \sqrt{\frac{\Delta P}{S}} \quad \text{or} \quad \Delta P = S \left(\frac{Q}{C_v} \right)^2$$

where... Q = flow rate (gallons per minute)
 ΔP = pressure drop across valve (psi)
 S = specific gravity of media

This equation is good for turbulent flow and for liquids with viscosities near that of water.
 (C_v is defined as the flow in GPM that a valve will carry with a pressure drop of 1.0 psi when the media is water at 60°F.) (The specific gravity of water is 1 (one).)

Valve Size	4	8	10	15	20	25	32	40	50	65	80	90	100	125	150	200
Size (mm.)	4	8	10	15	20	25	32	40	50	65	80	90	100	125	150	200
Size (In.)	1/8	1/4	3/8	1/2	3/4	1	1 1/4	1 1/2	2	2 1/2	3	3 1/2	4	5	6	8
GATES																
S/T-29	0.5	2	4.9	9.1	22	40	65	95	175							
S/T-111, 113, 131, 133, 134, 136, 154, 174, 176	—	5.6	10.7	17.6	32	54	97	135	230	337	536	710	960	1,525	2,250	
T/F-617, 619, 667, 669, 607, 609, F-637, 639									215	335	510	710	945	1,525	2,250	4,150
GLOBES																
S/T-211, 235, 256, 275-Y	0.61	1.16	2.2	3.64	6.65	11.1	20	28	48	70	111	—	198			
T-275-B	—	1.16	2.21	3.64	6.65	11.1	20	28	48	70	111					
F-718, F-738									45	70	105	—	195	315	465	860
CHECKS																
S/T-413, 433, 473 (Swing)	—	1.3	2.5	4.8	14.3	24	43	60	102	150	238	315	435	675	1,000	
S/T-480 (Poppet)	—	—	3.7	6.86	16.3	30	49	72	130							
F-908 (Swing)										243	356	—	665	1,073	1,584	2,937
T/F-918, 968, 938 (Swing)									137	221	327	—	605	975	1,440	2,670
KW-900-W									60	105	184	—	354	577	801	1,500
F-910, 960 (Poppet)										110	155	—	278	431	625	1,115
W-910, 960 (Poppet)									66	88	130	—	228	350	520	900
G-920-W									77	129	209	—	358	573	898	1,740
W-920-W									76	161	224	—	400	648	1060	1,890
BALL																
F-510, 530	—	—	—	11	25	45	—	137	217	—	482	—	790	—	1,144	2,164
F-515, 535	—	—	—	25	50	85	—	259	440	840	1,400	—	2,350	—	5,200	10,200
F-565	—	—	—	—	—	75	—	235	400	—	1,180	—	2,040	—	—	—
T-560-BR/CS/S6	—	4	4	5	12	22	35	52	95	—	—					
T-570	—	—	—	7	12	25	38	52	95	—	—					
T/S-580	—	—	—	5.8	13.9	27	44	64	100	—	—					
T/S-580-70	—	—	—	—	—	—	38.5	76	101.4	183	390					
T/S-585-70	—	4.2	6.2	15.3	30.4	48.8	103	143	245	—	—					
TM-585-70-66	—	—	—	15.3	30.4	48.8	103	143	245	—	—					
AT-585-70-66	—	—	—	—	—	—	—	—	—	183	—					
T-580-70-W3	—	—	—	—	—	—	21.6	38	48.5	—	—					
T/S-585-70-W3	—	—	—	6	12	19.5	—	—	—	—	—					
T-580 (CS-S6)	—	6	12	15	23	36	44	64	114	—	—					
T/S-590-Y	—	—	—	—	—	—	44	64	100	183	390					
T/S-595-Y	—	5.9	11.4	18.7	34	57	103	143	245	310	—					
TM/KM-595 (CS-S6)	—	6	12	19	37	64	103	143	245	—	—					
T/K-595 (CS-S6)	—	6	12	19	37	64	103	143	245	—	—					
BUTTERFLY																
LD/WD-1000, 2000, 3000									166	247	340	—	660	1,080	1,613	3,759
GD-4765, 4775 FC-2700, FD-5700									145	195	290	—	600	930	1,600	3,450

NOTE: flow data for angle valves use globe C_v times 1.25.
 Bronze Angles — 311, 335, 375, 376-AP
 Iron Angles — 818, 869, 831

Properties of Valve Materials

ALLOY	ASTM NO.	OTHER ALLOY DESIGNATION	NOMINAL OR MAXIMUM CHEMICAL COMPOSITION										
			CARBON		CHROME	COBALT	COPPER	IRON	LEAD	MANGA-NESE	MOLYB-DENUM		
			AL	C	Cr	Co	Cu	Fe	Pb	Mn	Mo		
Commercial Aluminum 380	SC 84 A (modified)	UNS A38000	87.0					1.0	1.3		.35		
Free Cutting Brass	B 16	UNS C36000						61.5		3.0			
Navy "M" (Steam Bronze)	B 61	UNS C92200	.005					88.0	.25	1.5			
Composition Bronze (Ounce Metal)	B 62	UNS C83600	.005					85.0	.30	5.0			
Copper-Silicon Alloy B	B 98/B 99	UNS C65100						96.0	.8	.05	.7		
Forging Brass	B 124	UNS C37700						60.0	.3	2.0			
Forging Brass	B 283	UNS C37700						58.0	.3	2.5			
Brass Wire (Red Brass)	B 134	UNS C23000						85.0	.05	.05			
Leaded Red Brass	B 140	UNS C31400						89.0	.10	1.9			
Aluminum Bronze (Cast)	B 148	UNS C95400	11.0					85.0	4.0				
Aluminum Bronze (Rod)	B 150	UNS C64200	7.0					91.0	.30	.05	.10		
Silicon Red Brass	B 371	UNS C69400						81.5	.20	.30			
Leaded Semi-Red Brass	B 584	UNS C84400	.005					81.0	.40	7.0			
Leaded Red Brass		UNS C84500	.005					78.0	.40	7.0			
Leaded Nickel Bronze	B 584	UNS C97600						64.0		4.0			
Copper (Wrot)	B 75	UNS C12200						99.9					
Gray Iron	A 126	Class B											
3% Ni Gray Iron	A 126 (modified)	Class B											
Austenitic Gray Iron (Ni-Resist)	A 436	Type 2		3.00	2.0			.5			1.0		
Ductile Iron (Ferritic)	A 395			3.20									
Austenitic Ductile Iron (Ductile)	A 536 65-45-12												
(Ductile)	A 536 80-55-06												
(Ni-Resist)	A 439 D2C			2.9	.5						2.4	1.0	

NOMINAL OR MAXIMUM CHEMICAL COMPOSITION								NOMINAL PHYSICAL PROPERTIES				
NICKEL Ni	PHOS P	SILICON Si	SULFUR S	TIN Sn	TITAN- IUM Ti	TUNG- STEN W	ZINC Zn	TENSILE STRENGTH Psi	YIELD STRENGTH Psi	% ELONGATION	HARDNESS	
.50		12.0		.15			.50	42,000	19,000	3.5		
							35.5	50,000	20,000	15	75 HRB	
1.0	.05	.005	.05	6.0			4.5	34,000	16,000	22	65 HB *500 kg	
1.0	.05	.005	.08	5.0			5.0	30,000	14,000	20	60 HB 500 kg	
		1.6					1.5	86,000**	20,000	11	65 HRB	
							38.0	52,000	20,000	45	80 HRB	
							38.0	52,000	20,000	45	78 HRB	
							15.0	56,000			60 HRB	
.7							9.1	50,000	30,000	7	60 HRB	
								75,000	30,000	12	170 HB *3000 kg	
.25		2.0		.20			.50	90,000	45,000	9	80 HRB	
		4.0					14.5	80,000	40,000	15	85 HRB	
	.02	.005	.08	3.0			9.0	29,000	13,000	18	55 HB *500 kg	
1.0	.02	.005	.08	3.0			12.0	29,000	13,000	16	55 HB *500 kg	
20.0				4.0			8.0	40,000	17,000	10	80 HB	
	.02							36,000	30,000	25	45 T	
	.75		.15					31,000			195 HB	
3.00	.75		.15					31,000			195 HB	
20.0		2.0	.12					25,000			118 HB	
	.08	2.50						60,000	40,000	18	167 HB	
	.08	2.50						65,000	45,000	12	160 HB	
	.08	2.50						80,000	55,000	6	160 HB	
24.0	.08	3.0						58,000	28,000	20	146 HB	

*Load Applied During Testing
**Allowable Range is 75,000 to 95,000

Properties of Valve Materials

ALLOY	ASTM NO.	OTHER ALLOY DESIGNATION	NOMINAL OR MAXIMUM CHEMICAL COMPOSITION									
			CARBON		CHROME	COBALT	COPPER	IRON	LEAD	MANGANESE	MOLYBDENUM	
			AL	C	Cr	Co	Cu	Fe	Pb	Mn	Mo	
Wrot 304	A 167 304	UNS S30400	.08		19						2	
Cast 316	A 351 CF8M	UNS S31600	.08		20						1.5	2.5
Cast 316	A 743 CF16F		.16		20						1.5	1.5
Cast 316	A 743 CF8M		.08		20						1.5	2.5
Stainless Steel	Wrot 316	A 276 316	UNS S31600	.08		17					2	
	Cast 410	A 217 CA 15		.15		13					1	2.5
	Forged 410	A 182 F6A2		.15		13					1	
	Wrot 410	A 276 410	UNS S41000	.15		13					1	
	Wrot 416	A 582	UNS S41600	.15		13					1.25	
	Wrot 420	A 276 420	UNS S42000	.15		13					1	
	Cast Alloy 20	A 743 CN7M		.07		20		3.5			1.5	2.5
	Wrot Alloy 20	B 473 20C63	UNS N08020	.07		20		3.5			2	2.5
	Wrot 17-4PH	A 564 630	UNS S17400	.07		16		3.5			1	
	Forged Carbon Steel	A 105		.35							1	
Cast Carbon Steel	A 216 WCB		.3							1.1		
Cast Carbon Steel	A 216 WCC		.25							1.2		
Steels	1¼ Cast Cr. Moly Steel	A 217 WC6		.2	1.2						.7	.55
	Cast Cr. Moly Steel	A 217 C5		.2	5						.55	.55
	Cast Low Carbon Steel	A 352 LCB		.3							1.0	
	Nickel-Low Carbon Steel	A 352 LC2		.25							.65	
	B-7 Alloy Steel Studs	A 193 B7		.4		1					.85	.2
Trim Steels	304 SS Nuts	A 194 GR8		.08		19					2	
	2-H Alloy Steel Nuts	A 194 2H		.4								
	Reg. Steel Bolting	A 307 Gr. B		.2							.45	
	Steel Bolting	A 449		.4							.6	
	304SS Bolting	A 493 304	UNS S30400	.08		19					2	
	Eyebolts	A 489		.48							1.0	
	Gland Nuts	A 563 Gr. A		.37		.55		.35			1.0	
	H/W Nuts	A 108 1020	UNS G10200	.20							.45	
	Swing Bolt Pin	A 108 1212	UNS G12120	.13							.85	
	Yoke Bushing Caps	A108 12L14		.15						.25	1.0	
Seat Ring Base	A 519 1026		.25							.75		
Monel H.F.	(Trademark Materials like, Stellite 6*, Stody 6, and Wallex 6)	AWS 5.13		1.25		29		55		2.5		
	Cast Monel	QQ-N-288-E	.5	.3				30	3.5		1.5	
Wrought Monel (K-500)	QQ-N-286-C1B	3.0	.1				24	2.0		1.5		

*Trademark by Cabot Corp.

NOMINAL OR MAXIMUM CHEMICAL COMPOSITION								NOMINAL PHYSICAL PROPERTIES			
NICKEL	PHOS	SILICON	SULFUR	TIN	TITAN- IUM	TUNG- STEN	ZINC	TENSILE STRENGTH	YIELD STRENGTH	% ELONGATION	HARDNESS
Ni	P	Si	S	Sn	Ti	W	Zn	Psi	Psi		
9	.045	1.0	.03					75,000	30,000	40	202 HB
11	.04	2.0	.04					70,000	30,000	25	
11	.04	2.0	.04					70,000	30,000	30	
12	.045	1.0	.03					75,000	30,000	30	
12	.045	1.0	.03					75,000	30,000	30	
1	.04	1.5	.04					90,000	65,000	18	
	.04	1.0	.03					85,000	55,000	18	200/225 HB
.5	.04	1.0	.03					100,000	80,000	15	
	.06	1.0	.15					114,000	95,000	17	235 HB
	.04	1.0	.03								250/450 HB
28	.04	1.5	.04					62,000	25,000	35	
35	.045	1.0	.035					85,000	35,000	30	
4	.04	1.0	.03					115,000	75,000	18	255 HB
	.04	.035	.05					70,000	36,000	22	187 HB
	.04	.6	.045					70,000	36,000	22	
	.04	.6	.04					70,000	40,000	22	
	.04	.06	.045								
	.04	.75	.045								
	.04	.6	.045					65,000	35,000	24	
2.5	.04	.6	.045					70,000	40,000	24	
	.035	.25	.04					125,000	105,000	16	
9	.045	1.0	.03								126/300 HB
	.04		.05								250/300 HB
	.04		.05					100,000		18	121/212 HB
	.04		.05					120,000	92,000	14	
9	.045	1.0	.03					90,000			
	.04	.25	.05					75,000	30,000	30	
.35	.04	.2	.05								
	.04		.05								120/300 HB
	.10		.20								
	.07		.3					55,000	35,000	25	
	.04		.05								
3						5		105,000		10	350 HB
60		1.5						65,000	32,500	25	125/150 HB
67		.5	.01		.5			135,000	95,000	20	255 HB

DIMENSIONAL REQUIREMENTS OF FLANGE/ PIPE CONNECTIONS FOR NIBCO® RUBBER SEATED LUG & WAFER STYLE BUTTERFLY VALVES

NIBCO butterfly valves, depending on size and pressure rating, are designed to mate with ASME B16.1, ASME B16.5, & ASME B16.47 series A flanges. Cast iron and steel flat-face flanges can be used with all NIBCO butterfly valves however steel raised-face flanges should not be used with cast grey iron lug style butterfly valves (NIBCO LC2000 and N200 series). While flange standards specify flange OD, thickness, bolt size, bolt circle diameter, and number of bolts, they may not specify flange opening ID. Care must be used when selecting mating components for use with NIBCO lug and wafer style butterfly valves. **The internal diameter of flanges, fittings, and pipe must be compatible with the butterfly valve for proper seal and operation.** When in the open position, the disc extends outward from the valve body. The internal diameter of connecting components must be large enough allowing clearance for the disc to fully open. The below disc clearances are in accordance with Butterfly Valve Standard MSS SP-67, Table A1.

NIBCO 2" thru 48" size butterfly valves have an integral rubber face that seals to the attaching flange, therefore a separate gasket is not necessary and should not be used. The flange inside diameter must not be too large or it will not mate properly with the seal. See below for minimum and maximum inside diameters of connecting piping/flanges to assure proper seal and operation of butterfly valves. Verify the inside diameter and clearance dimensions of all components connecting directly to a butterfly valve.

LD/WD/LC/WC1000/2000/3000 SERIES

VALVE SIZE	MINIMUM PIPE/FLANGE ID FOR DISC CLEARANCE	MAXIMUM FLANGE/PIPE ID FOR PROPER SEAL
2"	2.00"	2.49"
2 1/2"	2.37"	2.86"
3"	2.67"	3.43"
4"	3.69"	4.55"
5"	4.76"	5.62"
6"	5.84"	6.62"
8"	8.00"	8.62"
10"	10.00"	10.80"
12"	11.99"	13.12"
14"	13.02"	14.01"
16"	15.20"	16.30"
18"	17.09"	18.31"
20"	18.90"	20.08"
24"	23.05"	27.71"
30"	29.06"	30.29"
36"	33.59"	36.04"
42"	39.83"	42.77"
48"	44.85"	48.27"

These charts show the minimum and maximum inside diameters of connecting piping/flanges that will assure proper seal and operation with NIBCO butterfly valves. Verify the inside diameter and clearnace dimensions of all components connecting directly to the butterfly valve.

N200 SERIES

VALVE SIZE	MINIMUM PIPE/FLANGE ID FOR DISC CLEARANCE	MAXIMUM FLANGE/PIPE ID FOR PROPER SEAL
2"	1.38"	2.24"
2 1/2"	1.95"	2.74"
3"	2.66"	3.33"
4"	3.67"	4.55"
5"	4.48"	5.50"
6"	5.96"	6.66"
8"	7.85"	8.61"
10"	9.76"	10.75"
12"	11.72"	12.79"

Butterfly Valve Technical Information

Valve Installation Procedure - For Lug & Wafer Style Valves

Always position the connecting pipe flanges accurately in the line, allowing sufficient space between the flanges for the valve. Make sure the pipe flange faces are clean of any foreign material such as scale, metal shavings or welding slag. Valves should be installed with the disc in the closed position to prevent damage to sealing surfaces.

- Carefully insert the valves between the pipe flanges. Do not apply any lubricants to the seat faces as this may damage them.
- Line up, center and secure the valve between flanges using desired bolts or studs as listed in Table 4.
Do not tighten bolts at this time.
- Carefully open the valve to assure free unobstructed disc movement. Disc interference may result when valves are installed in pipelines having smaller than normal inside diameters, such as heavy wall pipe, plastic-lined pipe, as-cast flanges or reducing flanges. Interference can also occur when connecting directly to a swing check or silent check. Suitable corrective measures must be taken to remove these obstructions, such as taper boring the pipe or installing a spacer or spool piece.
- After proper operation is verified, tighten the bolts to the minimum recommended bolt torques listed in Table 3 below using a cross-over pattern, also shown below in Figure 3.
- Pressurize piping to valve and inspect for leakage. If leakage is observed, tighten bolts using cross-over pattern, increasing torque until leak stops.
DO NOT EXCEED MAXIMUM TORQUES LISTED IN TABLE 3.
- Recommended torques are made without warranty. Installer must verify proper strength bolts for application. Bolts shall be clean and un-lubricated.

NOTE: LUG STYLE VALVES - Extra care should be used when installing with raised face flanges. Over-tightening can result in broken lugs.

Caution

- Class 250 cast iron and Class 300 steel flanges **can not** be used on these valves.
- Rubber faced or mechanical flanges are **not** recommended.
- This valve is **not recommended** for steam service.
- Valves should **not** be assembled to the flanges and then welded into the piping system.
- Lever-lock handles are **not** recommended for use on 8" and larger valves.
- Do not install EPDM liner in compressed air lines.

Table 3 Recommended Bolt Tightening Torques

Flange Size	Bolt Size	Minimum Bolt Torque (ft.·lbs.)	Maximum Bolt Torque (ft.·lbs.)
2" - 4"	5/8"	20	70
5" - 8"	3/4"	30	120
10" & 12"	7/8"	50	200
14" & 16"	1"	70	240
18" & 20"	1-1/8"	100	380
24" & 30"	1-1/4"	140	520
36" - 48"	1-1/2"	200	800

Table 4 Recommended Bolt Lengths

VALVE SIZE 1000/2000/3000 SERIES ONLY	TOTAL VALVE BODY WIDTH	ANSI B16.1 CLASS 125 CAST IRON FLANGE THICKNESS	ANSI B16.5 CLASS 150 STEEL FLANGE THICKNESS	ANSI B16.47 (SERIES A) CLASS 150 STEEL MSS SP-44 FLANGE THICKNESS	RECOMMENDED CAP SCREW LENGTH (LUGGED VALVES) DIMENSION "Y"	RECOMMENDED BOLT LENGTH (WAFFER VALVES) DIMENSION "X"	TOTAL QUANTITY CAP SCREWS/BOLTS (TO MOUNT 2 FLANGES)	CAP SCREW SIZE
2"	1.69	0.63	—	—	1.25	4.00	8/4	5/8-11 UNC
		—	0.75	—	1.50	4.00	8/4	
2 1/2"	1.81	0.69	—	—	1.50	5.00	8/4	5/8-11 UNC
		—	0.88	—	1.75	5.00	8/4	
3"	1.81	0.75	—	—	1.50	5.00	8/4	5/8-11 UNC
		—	0.94	—	1.75	5.00	8/4	
4"	2.06	0.94	0.94	—	1.75	5.00	16/8	5/8-11 UNC
5"	2.19	0.94	0.94	—	1.75	5.00	16/8	3/4-10 UNC
6"	2.19	1.00	1.00	—	2.00	6.00	16/8	3/4-10 UNC
8"	2.38	1.12	1.12	—	2.25	6.00	16/8	3/4-10 UNC
10"	2.69	1.19	1.19	—	2.25	7.00	24/12	7/8-9 UNC
12"	3.00	1.25	1.25	—	2.50	7.00	24/12	7/8-9 UNC
14"	3.01	1.38	1.38	—	2.50	7.00	24/12	1-8 UNC
16"	3.38	1.44	1.44	—	3.00	8.00	32/16	1-8 UNC
18"	4.12	1.56	1.56	—	3.00	9.00	32/16	1 1/8-7 UNC
20"	5.14	1.69	1.69	—	3.50	10.00	40/20	1 1/8-7 UNC
24"	5.98	1.88	1.88	—	4.00	11.00	40/20	1 1/4-7 UNC
30"	6.57	2.12	—	—	3.50	—	56	1 1/4-7 UNC
		—	—	—	3.00	—	56	
		—	—	—	3.50	—	56	
		—	—	2.94	4.25	—	56	
36"	8.00	2.38	—	—	4.00	—	64	1 1/2-6 UNC
		—	—	—	3.50	—	64	
		—	—	—	4.00	—	64	
		—	—	3.56	5.00	—	64	
42"	9.88	2.62	—	—	4.50	—	72	1 1/2-6 UNC
		—	—	—	4.00	—	72	
		—	—	—	4.50	—	72	
		—	—	3.81	5.50	—	72	
48"	10.87	2.75	—	—	4.50	—	88	1 1/2-6 UNC
		—	—	—	4.50	—	88	
		—	—	—	5.00	—	88	
		—	—	4.25	6.00	—	88	

Bolt Tightening Cross Over Pattern

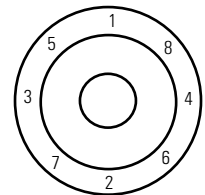
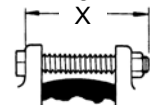
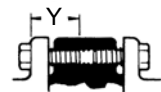

Fig. 3

Suggested Bolting Methods



WAFFER STYLE



LUG STYLE

Butterfly Valve Technical Information

Gear Operator Installation and Handwheel Positioning

Tools Required		
Fire Protection (UL/FM)	2" — 8"	9/16" hex wrench & 1/8" hex allen wrench
	10" — 12"	3/4" hex wrench and 1/8" hex allen wrench
Commercial	2" — 8"	9/16" hex wrench
	10" — 14"	3/4" hex wrench
	16" — 18"	1 1/8" hex wrench

INSTALLATION

1. Install handwheel (1) onto gear operator shaft and secure with pin (2).
(If not already attached) See Fig. 1.
2. Turn the handwheel (1) clockwise until in full SHUT position.
3. Remove 2 screws holding pointer cover plate to center of gear operator to expose bore. Retain pointer cover plate and screws for reinstallation later.
4. Assure valve is in full SHUT position, turn valve stem (5) to close disc if necessary.
5. Assure both mounting base of gear operator (3) and valve top flange (6) are clean and dry.
6. Determined desired handwheel position in reference to the piping system and compare with Fig. 2. Basically there are 2 mounting positions for the gear operator onto the valve and the valve can be mounted in either direction into the piping system. This will allow handwheel to be positioned in any of the 4 Quadrants as shown in Fig. 2. Note that 10" and 12" size commercial valves only allow for handwheel positioning in Quadrants 1 and 2.
- 7a. Gear operators **with** adapter bushing
 - Insert adapter bushing (4) into gear operator (3) bore aligning bushing key with desired keyway. Keyway selection will determine handwheel orientation position.
 - Align adapter bushing (4) bore with valve stem (5) and slide gear operator assembly onto valve stem (5) until seated with valve top flange.
- 7b. Gear operators **without** adapter bushing
 - Align gear operator (3) bore with valve stem (5) and align with desired keyway. Keyway selection will determine handwheel orientation position.
 - Slide gear operator assembly onto valve stem (5) until seated with valve top flange.
8. Secure gear operator (3) to valve top flange (6) using supplied* fasteners (7 & 8).
9. Reinstall pointer cover plate onto gear operator that you removed in step 3 above. Arrow should be aligned to indicate SHUT position.
10. Rotate handwheel from full SHUT to full OPEN positions several times to assure proper operation.
11. Proceed with valve installation into piping system.

*A minimum of two fasteners is required, installed in opposite diagonal corners.

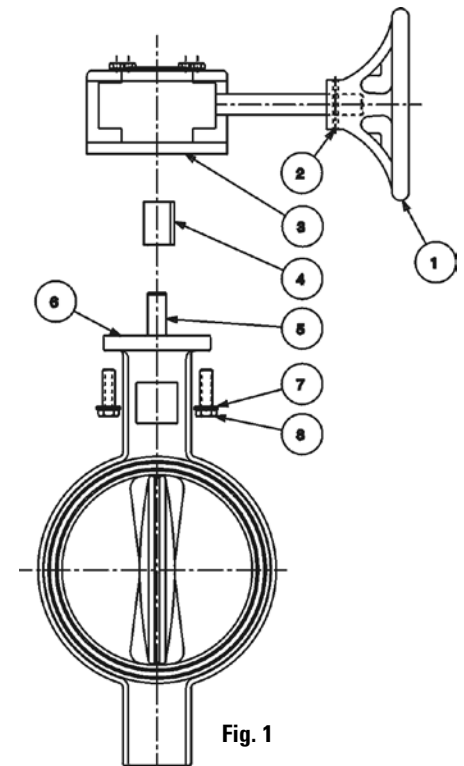

Fig. 1

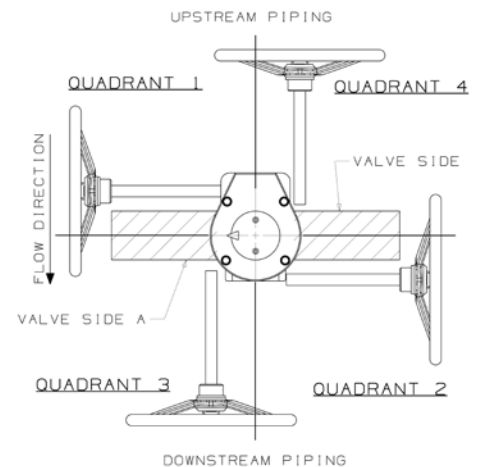
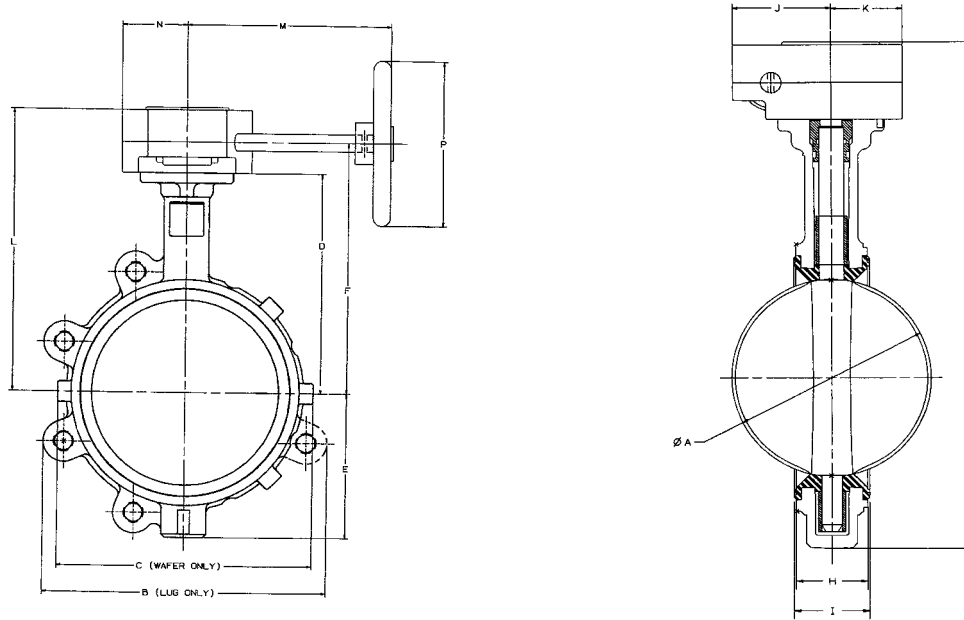

Fig. 2

Note - connection of gear operator to valve stem varies depending on gear operator model, size and style. The adapter bushing and key may be different from illustration shown.

2000/3000 Series Technical Information

Valve with Gear Mounted



Typical LD/WD2000-5 and LD1000-5

DIMENSIONS

Valve Size	A	B (Lug)	C (Wafer)	D	E	F	G	H (Metal)	I (Rubber)	J	K	L	M	N	P
2"	2.5	4.6	4.9	5.4	2.9	6.9	11.1	1.69	1.81	2.9	2.13	8.2	7.64	2.12	5.91
2½"	2.9	5.6	5.6	5.9	3.3	7.4	12.0	1.81	1.94	2.9	2.13	8.7	7.64	2.12	5.91
3"	3.1	6.1	6.1	6.1	3.4	7.6	12.3	1.81	1.94	2.9	2.13	8.9	7.64	2.12	5.91
4"	4.1	8.3	7.0	6.9	4.0	8.4	13.7	2.06	2.19	2.9	2.13	9.7	7.64	2.12	5.91
5"	5.1	9.4	8.3	7.4	4.8	8.9	15.0	2.19	2.31	2.9	2.13	10.2	7.64	2.12	5.91
6"	6.1	10.3	9.3	8.0	5.3	9.5	16.1	2.19	2.31	2.9	2.13	10.8	7.64	2.12	5.91
8"	8.1	13.4	11.6	9.3	6.5	10.8	18.5	2.38	2.5	2.9	2.13	12.0	9.53	2.12	9.84
10"	10.1	15.5	14.3	10.5	8.0	12.3	21.8	2.69	2.81	3.9	3.03	13.8	11.54	3.03	9.84
12"	12.1	18.3	16.8	12.0	9.3	13.8	24.6	3.00	3.13	3.9	3.03	15.3	11.54	3.03	9.84
14"	13.1	-	20.6	14.5	10.5	16.3	28.3	3.01	3.13	4.3	3.15	17.8	12.87	3.14	11.81
16"	15.3	-	22.3	15.7	11.7	17.9	31.7	3.38	3.54	6.3	3.94	20.0	13.58	4.92	11.81
18"	17.3	-	25.2	16.6	12.4	18.8	33.3	4.12	4.29	6.3	3.94	20.9	15.04	4.92	15.75
20"	19.4	-	27.4	18.9	13.7	21.3	37.8	5.14	5.31	6.5	4.92	24.1	18.11	4.92	11.81
24"	23.3	-	31.5	22.1	17.5	24.5	44.8	5.98	6.14	6.5	4.92	27.3	18.11	4.92	11.81

Butterfly Valve Technical Information

Resilient Liner Materials

EPDM – EPDM is a terpolymer elastomer made from ethylene-propylene diene monomer. EPDM has good abrasion and tear resistance and offers excellent chemical resistance to a variety of acids and alkalines. It is susceptible to attack by oils and is not recommended for applications involving petroleum oils, strong acids, or strong alkalines. EPDM should not be used on compressed air lines. It has exceptionally good weather aging and ozone resistance. It is fairly good in ketones and alcohols.

BUNA-N (Nitrile) (NBR) – Buna-N is a general purpose oil resistant polymer known as nitrile rubber. Nitrile is a copolymer of butadiene and acrylonitrile. Buna-N has good solvent, oil, water and hydraulic fluid resistance. It displays good compression set, abrasion resistance and tensile strength. Buna-N should not be used in highly polar solvents such as acetone and methyl ethyl ketone, nor should it be used in chlorinated hydrocarbons, ozone or nitro hydrocarbons. Some aviation fuels may not be compatible.

Fluoroelastomer (FKM) – Fluoroelastomers are inherently compatible with a broad spectrum of chemicals. Because of this extensive chemical compatibility which spans considerable concentration and temperature ranges, fluoroelastomers have gained wide acceptance as a material of construction for butterfly valve O-rings and seats. Fluoroelastomer can be used in most applications involving mineral acids, salt solutions, chlorinated hydrocarbons and petroleum oils. It is particularly good in hydrocarbon service.

FKM is not recommended for use in high temperature water.

Liner Temperature Ratings

Liner Material	Temperature
EPDM**	-20°F to + 250°F
Nitrile (Buna-N)	-20°F to + 180°F
Fluoroelastomer	-20°F to + 300°F

**EPDM is rated at 250°F intermittent service and 225°F continuous service.

NOTE – the NIBCO Chem-Guide® should be referenced for liner material compatibility for each application.

Proprietary compound formulas are used for each of the elastomers to provide the right combination of seat compression, abrasion resistance, and chemical resistance to match your application. Elastomeric seat materials are not suitable for steam service.

Butterfly Valve Technical Information

Metals Used in Valves & Fittings

Aluminum—A non-ferrous metal, very lightweight, approximately one-third as much as steel. Aluminum exhibits excellent atmospheric corrosion resistance, but can be very reactive with other metals. In valves, aluminum is mainly used as an exterior trim component such as a handwheel or identification tag.

Copper—Among the most important properties of wrought copper materials are their thermal and electrical conductivity, corrosion resistance, wear resistance, and ductility. Wrought copper performs well in high temperature applications and is easily joined by soldering or brazing. Wrought copper is exclusively used for fittings.

Bronze—One of the first alloys developed in the bronze age is generally accepted as the industry standard for pressure rated bronze valves and fittings. Bronze has a higher strength than pure copper, is easily cast, has improved machinability, and is very easily joined by soldering or brazing. Bronze is very resistant to pitting corrosion, with general resistance to most chemicals less than that of pure copper.

Silicon Bronze—Has the ductility of copper but much more strength. Silicon bronze has equal or greater corrosion resistance to that of copper. Commonly used as stem material in pressure-rated valves, silicon bronze has greater resistance to stress corrosion cracking than common brasses.

Aluminum Bronze—The most widely accepted disc material used in butterfly valves, aluminum bronze is heat treatable and has the strength of steel. Formation of an aluminum oxide layer on exposed surfaces makes this metal very corrosion resistant. Not recommended for high pH wet systems.

Brass—Generally good corrosion resistance. Susceptible to de-zincification in specific applications; excellent machinability. Primary uses for wrought brass are for ball valve stems and balls, and iron valve stems. A forging grade of brass is used in ball valve bodies and end pieces.

Gray Iron—An alloy of iron, carbon and silicon; easily cast; good pressure tightness in the as-cast condition. Gray iron has excellent dampening properties and is easily machined. It is standard material for bodies and bonnets of Class 125 and 250 iron body valves. Gray iron has corrosion resistance that is improved over steel in certain environments.

Ductile Iron—Has composition similar to gray iron. Special treatment modifies metallurgical structure which yields higher mechanical properties; some grades are heat treated to improve ductility. Ductile iron has the strength properties of steel using similar casting techniques to that of gray iron.

Carbon Steel—Very good mechanical properties; good resistance to stress corrosion and sulfides. Carbon steel has high and low temperature strength, is very tough and has excellent fatigue strength. Mainly used in gate, globe, and check valves for applications up to 850°F, and in one-, two-, and three-piece ball valves.

3% Nickel Iron—Improved corrosion resistance over gray and ductile iron. Higher temperature corrosion resistance and mechanical properties. Very resistant to oxidizing atmospheres.

Nickel-Plated Ductile Iron—Nickel coatings have received wide acceptance for use in chemical processing. These coatings have very high tensile strength, 50 to 225 ksi. To some extent, the hardness of a material is indicative of its resistance to abrasion and wear characteristics. Nickel plating is widely specified as a disc coating for butterfly valves.

400 Series Stainless Steel—An alloy of iron, carbon, and chromium. This stainless is normally magnetic due to its martensitic structure and iron-content. 400 series stainless steel is resistant to high temperature oxidation and has improved physical and mechanical properties over carbon steel. Most 400 series stainless steels are heat-treatable. The most common applications in valves are, for stem material in butterfly valves, and backseat bushings and wedges in cast steel valves.

316 Stainless Steel—An alloy of iron, carbon, nickel, and chromium. A non-magnetic stainless steel with more ductility than 400SS. Austenitic in structure, 316 stainless steel has very good corrosion resistance to a wide range of environments, is not susceptible to stress corrosion cracking and is not affected by heat treatment. Most common uses in valves are: stem, body and ball materials.

17-4 PH Stainless Steel*—Is a martensitic precipitation/age hardening stainless steel offering high strength and hardness. 17.4 PH withstands corrosive attack better than any of the 400 series stainless steels and in most conditions its corrosion resistance closely approaches that of 300 series stainless steel. 17.4 PH is primarily used as a stem material for butterfly and ball valves.

Alloy 20Cb-3*—This alloy has higher amounts of nickel and chromium than 300 series stainless steel and with the addition of columbium, this alloy retards stress corrosion cracking and has improved resistance to sulfuric acid. Alloy 20 finds wide use in all phases of chemical processing. Commonly used as interior trim on butterfly valves.

Monel*—Is a nickel-copper alloy used primarily as interior trim on butterfly and ball valves. One of the most specified materials for corrosion resistance to sea and salt water. Monel is also very resistant to strong caustic solutions.

Stellite*—Cobalt base alloy, one of the best all-purpose hard facing alloys. Very resistant to heat, abrasion, corrosion, impact, galling, oxidation, thermal shock and erosion. Stellite takes a high polish and is used in steel valve seat rings. Normally applied with transfer plasma-arc; Stellite hardness is not affected by heat treatment.

Hastelloy C*—A high nickel-chromium molybdenum alloy which has outstanding resistance to a wide variety of chemical process environments including strong oxidizers such as wet chlorine, chlorine gas, and ferric chloride. Hastelloy C is also resistant to nitric, hydrochloric, and sulfuric acids at moderate temperatures.

Note: See the NIBCO Chemical Resistance Guide for specific questions.

*Alloy 20Cb-3 is a registered trademark of Carpenter Technology

*Hastelloy C is a registered trademark of Cabot Corporation

*Stellite is a registered trademark of Cabot Corporation

* Monel is a registered trademark of International Nickel

*17-4 PH Stainless Steel is a registered trademark of Armco Steel Company

Butterfly Valve Technical Information

Torque Data

LD/WD 2000/3000/5022 Series Torque Data (In. Lbs.)

Size	100 PSI	200 PSI	250 PSI
2"	140	180	195
2 1/2"	190	235	255
3"	250	300	325
4"	430	530	580
5"	590	790	845
6"	795	1,035	1,155
8"	1,850	2,350	2,600
10"	2,350	2,900	3,125
12"	3,875	5,390	6,145

LD/WD 1000/2000 Series Torque Data (In. Lbs.)

Size	50 PSI	75 PSI	100 PSI	150 PSI
14"	—	3,837	—	4,870
16"	—	5,003	—	6,685
18"	—	6,567	—	8,958
20"	—	8,540	—	11,950
24"	—	13,220	—	18,680
30"	28,320	29,782	30,864	33,336
36"	40,624	41,875	43,480	46,528
42"	69,744	72,076	74,632	79,864
48"	96,648	100,520	103,840	111,112

N200 Series Torque Data (In. Lbs.)

Size	100 PSI	200 PSI
2	120	220
2 1/2	130	320
3	180	480
4	280	820
5	360	1,162
6	600	1,560
8	1,100	2,890
10	2,040	5,270
12	4,500	8,050

Note: Torque Data shown is for general service (clean water, ambient temperatures). For non-lubricating, high temperatures or aggressive media, consult Nibco Technical Service.

Butterfly Valve Torque Data

Torque is the rotary effort required to operate a valve. This turning force in a butterfly valve is determined by three factors. (1) Friction of the disc to seat for sealing (2) Bearing friction (3) Dynamic torque.

Breakaway Torque is the total of the torques resulting from bearing friction and seat/disc interference friction at a given pressure differential. This value is normally the highest required torque to operate a valve, and is used in sizing actuators. The values listed at the left are based on performance tests and include a safety factor. The torques listed are valid for water and lubricating fluids at ambient temperature. For dry and non-lubricating fluids, contact your NIBCO customer service representative.

Butterfly valves, sizes 8" and larger, when used on liquids, show a marked increase in dynamic torque which tends to close the valve. For this reason, gear operated or actuated valves are recommended.

Torque listed for EPDM. When calculating torques for Buna-N, or Fluoroelastomer multiply listed torque by 1.25. Consult factory for dry service valves.

FC/FD27*5/57*5 GD4765/4775 Torque Data (In. Lbs.)

Size	100 PSI	200 PSI	300 PSI
2	48	67	83
2 1/2	48	67	83
3	100	134	168
4	185	251	317
5	294	410	499
6	520	705	890
8	1,070	1,495	1,798
10	1,550	2,214	2,654
12	2,150	3,024	3,662

Note: See Pages 38-39 for High Performance BFV Torque Data.

Butterfly Valve Actuation Data Sheet

To actuate all valves it is necessary to provide certain data to assure proper sizing and prevent damage to the system. Please supply as much data as possible.

I. Valve Information:

A. Type: Butterfly Ball

B. Fig. No. _____ **Size** _____ **Qty.** _____

C. Type of Fluid in Valve: _____ **Inlet Pressure:** _____ **Is Fluid:** Dry Wet

Differential Pressure: _____ **System Velocity:** _____

System GPM: _____ **Temperature:** _____

II. Actuator Information:

A. Electric: **Voltage:** _____ **Time for 90° rotation:** _____

Type Enclosure: NEMA 4 NEMA 7 Other _____

Special Requirements: Brake Thermostat Heater and Thermostat

Manual Override Extended Duty Motor

Modulating Control Position Transmitter

Extra SPDT Switches Potentiometer

B. Pneumatic: **Air supply to actuator:** _____ **PSI (Min. 40 psi, Max. 120 psi)**

Actuator Type: Air-to-Air

Air-to-Spring **Failsafe:** Open Closed

Solenoid: NEMA 4 NEMA 7

Switch Box: If so: NEMA 4 NEMA 7

Type: SPDT DPDT (two each is standard)

Pneumatic Positioner: 3-15 4-20 MA

III. Special Notes: _____

Note: If special features are required for actuators such as modulating positioners either for electric or pneumatic actuators, consult factory.

Figure Number Comparisons*

Butterfly Valves

DUCTILE IRON

NIBCO	WD2000	LD2000	WD2100	LD2100	WD3010	LD3010	WD3110	LD3110	WD3022	LD3022
Bray	30-11010-120	31-11010-120	30-11010-684	31-11010-684	30-11010-119	31-11010-119	30-11010-713	31-11010-713	30-11010-124	31-11010-124
Centerline	A2-061-05	B2-061-05	A2-061-01	B2-061-01	A2-021-05	B2-021-05	A2-021-01	B2-021-01	A2-044-05	B2-044-05
Demco	NEC1114351	NEC5114351	NEC1114311	NEC5114311	NEC1115351	NEC5115351	NEC1115311	NEC5115311	NEC1122351	NEC5122351
Grinnell	WD-8281-3	LD-8281-3	WD-8181-3	LD-8181-3	WD-8201-3	LD-8201-3	WD-8101-3	LD-8101-3	WD-8271-4	LD-8271-4
Keystone	HS-1	HS-2	HS-1	HS-2	HS-1	HS-2	HS-1	HS-2	HS-1	HS-2
Milwaukee	MW-233-E	ML-233-E	MW-233-B	ML-233-B	MW-232-E	ML-232-E	MW-232-B	ML-232-B	MW-234-E	ML-234-E
Mueller Steam	55-ANK6-1	56-ANK6-1	55-ANK3-1	56-ANK3-1	55-ANI6-1	56-ANI6-1	55-ANI3-1	56-ANI3-1	55-AHH6-1	56-AHH6-1
Watts	DBF-04-121-15	DBF-03-121-15	DBF-04-121-25	DBF-03-121-25	DBF-04-111-15	DBF-03-111-15	DBF-04-111-25	DBF-03-111-25	DBF-04-131-25	DBF-03-131-25

NOTE: NIBCO lug style butterfly valves are fully rated for dead end service without a downstream flange. All valves listed above as comparable may not have this rating.

CAST IRON

NIBCO	N200235	N200135	N200245	N200145	N200236	N200136	N200246	N200146
Grinnell	LC128*3	WC128*3	LC118*3	WC118-3	LC120*3	WC120*3	LC110*3	WC110*3
Centerline	B106135	A106145	B106161	A106131	B102135	A102135	B102131	A102131
Watts	BF03-121-1	BF04-121-1	BF03-121-2	BF04-121-2	BF03-111-1	BF04-111-1	BF03-111-2	BF04-111-2
Milwaukee	CL223E	CW223E	CL223B	CW223B	CL222E	CW222E	CL222B	CW222B

*To be used as a guide only. Some variation in detail is possible.
Information subject to change.

globally connecting you at all levels

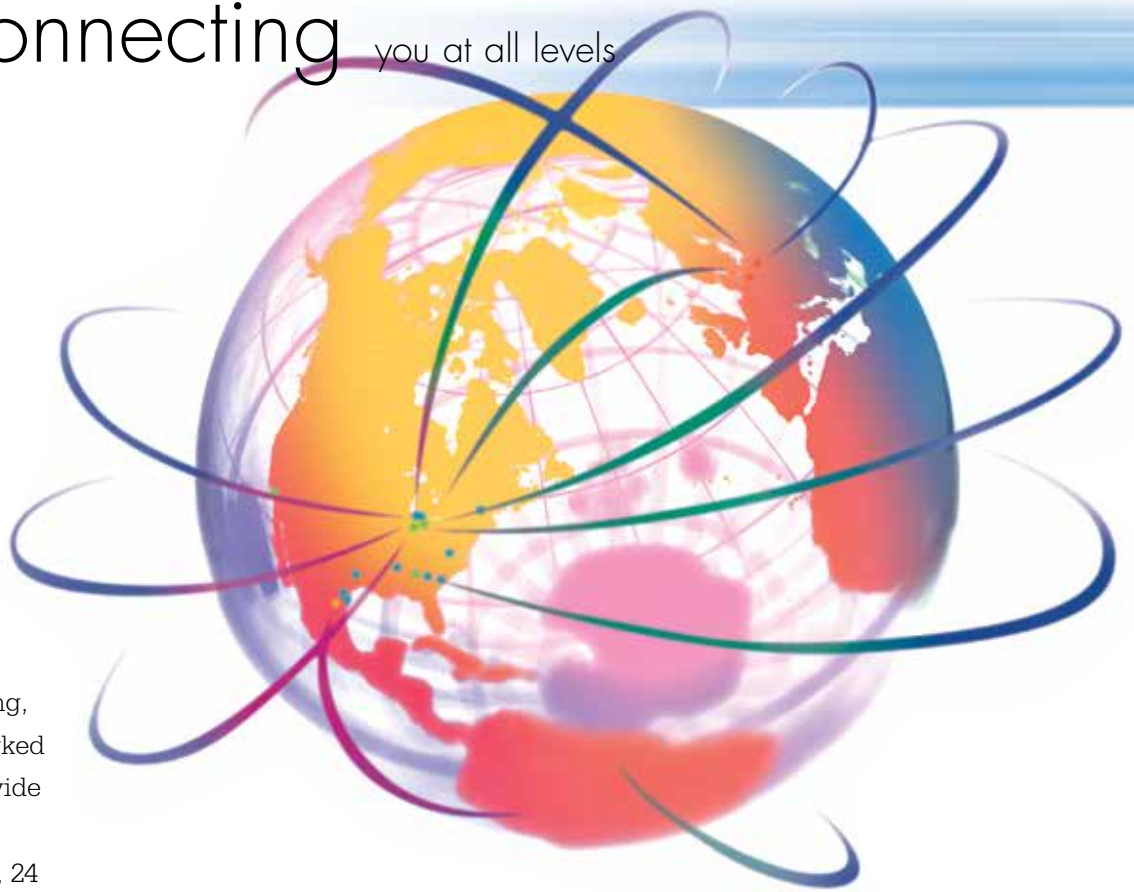

It's a new age of business, and a new way at NIBCO. From Elkhart, Indiana to Lodz, Poland, and points beyond, our company has integrated manufacturing, distribution, and networked communications to provide a seamless source of information and service, 24 hours a day, 7 days a week. But this integration hasn't happened overnight. It's been part of a long-term strategic process that has pushed us to reconsider every aspect of our business. The result? We're a vertically integrated manufacturer with the products and systems in place to deliver low cost and high quality. NIBCO products are manufactured under a Quality Management System conforming to the current revision of ISO-9001 International Standards. We know the flow control industry is only going to get more demanding, and we are more than ready. We will continue to lead. That's what NIBCO is all about.



FEATURING NIBCO® SYSTEMS

C-BFV-0916

NIBCO® PEX Piping Systems • NIBCO® Press System®

FITTINGS

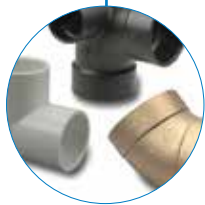

Wrot and cast copper pressure and drainage fittings • Cast copper alloy flanges
• Wrot and cast press fittings • ABS and PVC DWV fittings • Schedule 40 PVC pressure fittings • CPVC CTS fittings • CPVC CTS-to-metal transition fittings
• Schedule 80 PVC and CPVC systems • CPVC metric piping systems
• CPVC BlazeMaster® fire protection fittings • Lead-Free* fittings

BlazeMaster® is a registered trademark of The Lubrizol Corporation.
*Weighted average lead content ≤0.25%

VALVES & ACTUATION

Pressure-rated bronze, iron and alloy-iron gate, globe and check valves • Pressure-rated bronze ball valves • Boiler specialty valves • Commercial and industrial butterfly valves • Circuit balancing valves • Carbon and stainless steel ball valves
• ANSI flanged steel ball valves • Pneumatic and electric actuators and controls
• Grooved ball and butterfly valves • High performance butterfly valves • UL/FM fire protection valves • MSS specification valves • Bronze specialty valves • Low pressure gate, globe, check and ball valves • Frostproof sillcocks • Quarter-turn supply stops • Quarter-turn low pressure valves • PVC ball valves • CPVC CTS ball valves • Bronze & Iron Y-Strainers • Lead-Free* valves • Coil-Connect™ Kits

*Weighted average lead content ≤0.25%



CHEMTROL®



Thermoplastic pipe, valves and fittings in PVC, Corzan® CPVC, polypropylene and PVDF Kynar® • Pneumatic and electric actuation systems

Corzan® is a registered trademark of The Lubrizol Corporation. • Kynar® is a registered trademark of Arkema Inc.

eNIBCO

EDI—Electronic Data Interchange • VMI—Vendor Managed Inventory
• NIBCO.com • NIBCOpartner.com



NIBCO®
AHEAD OF THE FLOW®

NIBCO INC.
WORLD HEADQUARTERS
WEB: www.nibco.com

1516 MIDDLEBURY STREET
ELKHART, IN 46516-4740
USA

DOMESTIC CUSTOMER SERVICE
PHONE: 800.234.0227
FAX: 800.234.0557

TECHNICAL SERVICE
PHONE: 888.446.4226
FAX: 888.336.4226

INTERNATIONAL OFFICE
PHONE: +1/574.295.3327
FAX: +1/574.295.3455