



TADIRAN AIROW 3™

Hydrogen Peroxide Aerosol Disinfectant

Any Space Can Be
a Safe Place.

Tadiran is Leading the Future of Air

Our vision is to have a positive impact on people's health and quality of life through innovative, environmentally friendly technologies that provide improved indoor air.

For over 60 years, as an industry leader, Tadiran Group has applied its engineering knowledge to the development and manufacture of world-class trusted air conditioners. Now, we are putting our expertise towards air quality technologies, because nothing is more important than the air we breathe.

Welcome to the future of air.



TADIRAN AIROW 3™

Hydrogen Peroxide Aerosol Disinfector



A Remedy Against Harmful Pathogens

The COVID-19 pandemic has heightened awareness of the importance of air quality in our lives. We spend most of our days indoors and according to studies, indoor air can be up to 5 times more polluted than outdoor air.

Introducing TADIRAN AIROW 3™ a unique Hydrogen Peroxide purifier that reduces airborne pathogens. It is an effective, robust air purification device.

TADIRAN AIROW 3™ devices provide powerful air purification, eliminating certain known aerosolized pathogens including SARS-CoV-2⁷, viruses⁸, bacteria⁹, and mold¹⁰. It has no ion emission, requires no maintenance, is plug-and-play, and consumes very little energy.



TADIRAN AIROW 3™

Pathogens Disinfectant

TADIRAN AIROW 3™ is a H_2O_2 based air-purifier for wall-mounted A/C. It is designed for easy installation² into any ducted HVAC system, is a Zero Ozone Verified³ device, requires no maintenance, and consumes minimal energy.

How it Works

TADIRAN AIROW 3™ uses a discharge current to break apart O_2 (Oxygen) molecules into two separate O atoms. The free oxygen atoms combined with water (H_2O) molecules in the airflow, transform into purifying Hydrogen Peroxide (H_2O_2). The Hydrogen Peroxide is then distributed through the indoor air conditioning unit traveling into the conditioned space thus eliminating aerosol pathogens.



Indoor Air Quality Matters

96%

of all homes
are polluted⁶

90%

of our time is
spent indoors⁶

WHY CHOOSE WHEN YOU CAN FUSE?

The Effective and Safe Choice

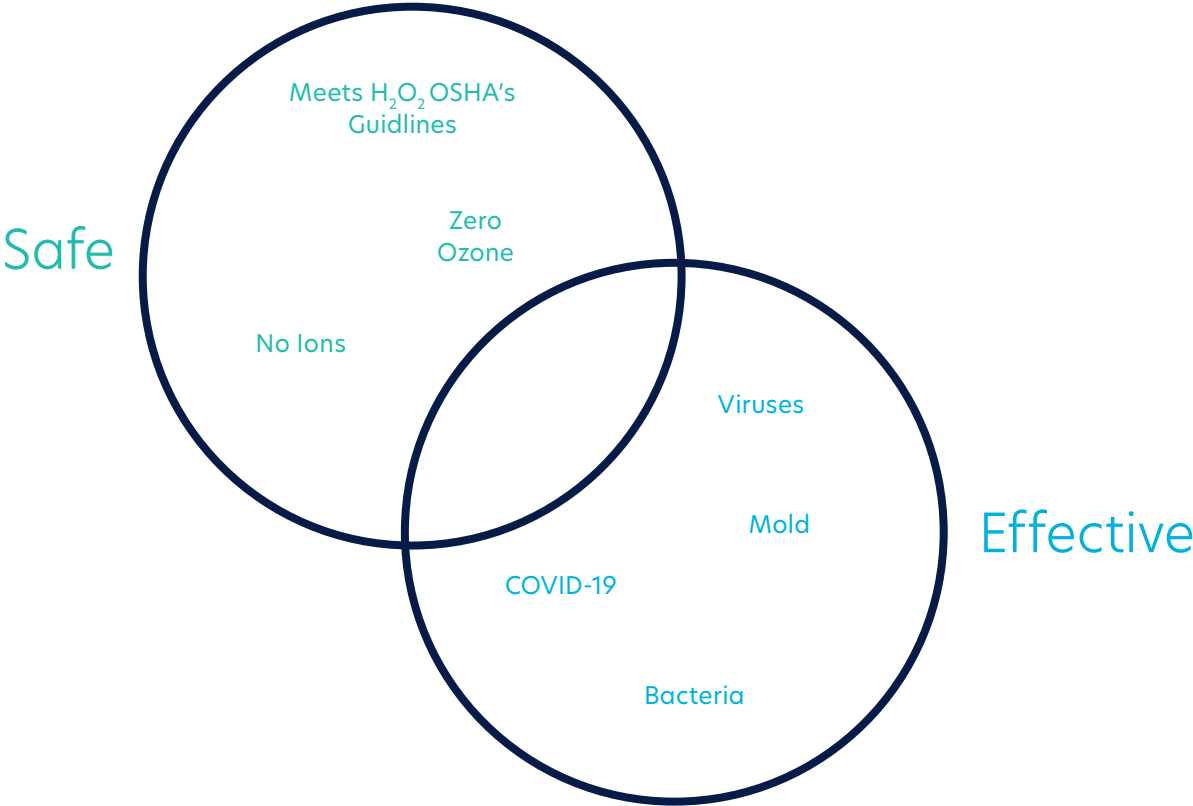

H₂O₂
Patented Technology



Ozone Free⁵



Plug & Play
Installation⁴



Highly Effective
Against Biological
Pathogens



Zero
Maintenance



Low Electricity
Usage

PRODUCT SPECS

Specification Type	Title	Value
Electrical	Power Supply Input Voltage	100 to 240 VAC
	Power Supply Output Voltage	12 VDC \pm 10%
	Device Power Consumption	1 W Max
Mechanical	Weight	100g
	Dimensions	108 x 48 x 26mm
	Housing Material	ABS Plastic
	Color	White
Environment	Operation Temperature	-5°C to +55°C
	Operation Humidity (Non-Condensing)	20%-85%
	Air Flow Rating	2720 m ³ /H
Features	Maintenance Free	Zero Maintenance
	LED Indication	Green: Proper Operation / Red: Failure
Gas Emission	Hydrogen Peroxide Concentration	\leq 15 ppb
	Ozone Concentration	\leq 5 ppb

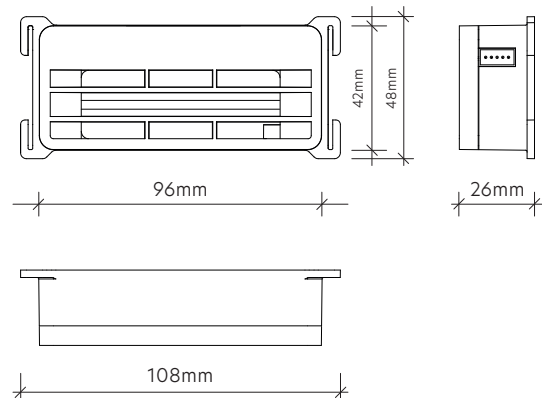

BACKED BY SCIENCE

Bioaerosol Type	Species/Protocol	Testing Lab	Results
Bacteria	Streptococcus pyogenes (Group A) Chamber size: 36m ³ , after 120 min	Innovative Bioanalysis Labs, USA	100% ²
	Staphylococcus Epidermis vegetative (+) Chamber size: 1m ³ , after 60 min	Aerosol Research and Engineering Laboratories, USA	99.994% ⁹
COVID Virus	SARS-CoV-2 Chamber size: 16m ³ , after 60 min	Innovative Bioanalysis Labs, USA	99.93% ⁷
Virus	RNA Virus MS2 Bacteriophage Chamber size: 1m ³ , after 60 min	Aerosol Research and Engineering Laboratories, USA	99.994% ⁸
Mold Spore	Blue Mold (Penicillium Citrinum) Aerosolized Chamber size: 25m ³ , after only 3 hours	Kitazao Laboratory, Japan	99.4% ¹⁰
Ozone Emission	UL 867 Section 40	INTERTEK	<5 ppb ⁵ Tested



¹TADIRAN AIROW 3 device was tested in the US-based internationally recognized laboratory Innovative Bioanalysis, which is BSL3 accredited. ²TADIRAN AIROW 3 reduced the aerosol of Streptococcus pyogenes in 36 cubic meter test chamber, by 100% within 120 min. ³Independent tests commissioned by Tadiran showed that TADIRAN AIROW™ technology eliminated known aerosolized pathogens under optimal testing conditions. To learn more about the tests, visit www.tadiran-international.com/scientific-testing. ⁴Only qualified and licensed HVAC technicians may install TADIRAN AIROW. ⁵TADIRAN AIROW is verified as zero ozone. Does not emit more than 0.005PPM as tested per UL 867. ⁶World Health Organization EPA report on the environment <https://www.epa.gov/report-environment/indoor-air-quality>. Pre COVID-19. ⁷TADIRAN AIROW 3 reduced detected SARS-CoV-2 aerosol levels by 99.93% within 1 hour (16 cubic meter test chamber). ⁸TADIRAN AIROW 3 reduced MS2 levels by 99.994% in 1 hour (1 cubic meter test chamber). ⁹TADIRAN AIROW 3 reduced detected Bacteria Staphylococcus epidermidis aerosol levels by 99.994% within 1 hour (1 cubic meter test chamber) ¹⁰TADIRAN AIROW 3 reduced Aerosol of Blue Mold by 99.4% within 3 hours in a 25m³ chamber. ¹¹TADIRAN AIROW 3 creates <15 ppb H₂O₂ based on a test conducted by LSC Laboratory inc. ¹²TADIRAN AIROW 3, tested by TUV and Intertek, does not emit more than 0.005PPM. ¹³All pictures shown are for illustration purposes only. Actual product may vary.



TADIRAN

www.tadiran-international.com | info@tadiran-international.com

For more details regarding Terms and Conditions and Privacy Policy, visit our website: www.tadiran-international.com
Copyright © 2022 - Tadiran International. All rights reserved. This document may be revised by Tadiran at any time.