

Model 1610 Easy Install™ Air Cleaner*

- Model 1610 is a whole home air cleaner designed for easy installation in upflow HVAC systems with right or left returns.
- Built-in ductwork for applications that require a 90° duct adapter eliminates the need for field forming transitions, significantly reducing installation time
- The return opening is adjustable, from 8" to 10"
- Cabinet includes metal tabs which can be used to secure the cabinet to the furnace or air handler during installation
- Recommended air flow is up to 2000 CFM
- Includes MERV 11 Media
- Proprietary design protects your replacement media business
- Collapsible media with self spacing pleats
- SelfSeal™ reduces air bypass and improves performance
- Self aligning painted door easily snaps into place every time
- Warrantied for five (5) years from date of installation to be free from defects in materials or workmanship. Media is disposable and does not apply to warranty
- Media replacement is recommended after one year



Model 410

- MERV 11 media permanently traps 56% of respirable dust particles and pet dander (1+ microns).
- MERV 11 media permanently traps up to 94% of mold and spore-sized particles (6 microns).
- MERV 11 media permanently traps up to 95% of pollen-sized particles (10 microns).

* Patent Pending

Model 413

- MERV 13 media permanently traps over 96% of respirable dust and pet dander sized particles (1+ microns).
- MERV 13 media permanently traps up to 97% of bacteria sized particles (2+ microns).
- MERV 13 media permanently traps over 98% of pollen, mold and spore sized particles (6 to 10 microns).
- MERV 13 media permanently traps over 75% of tobacco, smoke and smog sized particles (0.3 to 0.9 microns)

PRODUCT SPECIFICATIONS

1610 UNITS

REPLACEMENT MEDIA

	Shipping Weight	Nominal Size		Resistance @ Airflow Volume (inches w.c. @CFM)	Shipping Weight (full carton)	Filtering Media Area
Model 1610	22 lbs.	16" x 25" Easy Install	Model 410 (MERV 11)	.05"@600 .15"@1400 .07"@800 .19"@1600 .09"@1000 .22"@1800 .12"@1200 .27"@2000	27.8 lbs.	28.3 sq. ft.
			Model 413 (MERV 13)	.06"@600 .22"@1400 .09"@800 .26"@1600 .13"@1000 .31"@1800 .17"@1200 .37"@2000		



APRILAIRE MODEL 1610 MEDIA AIR CLEANER

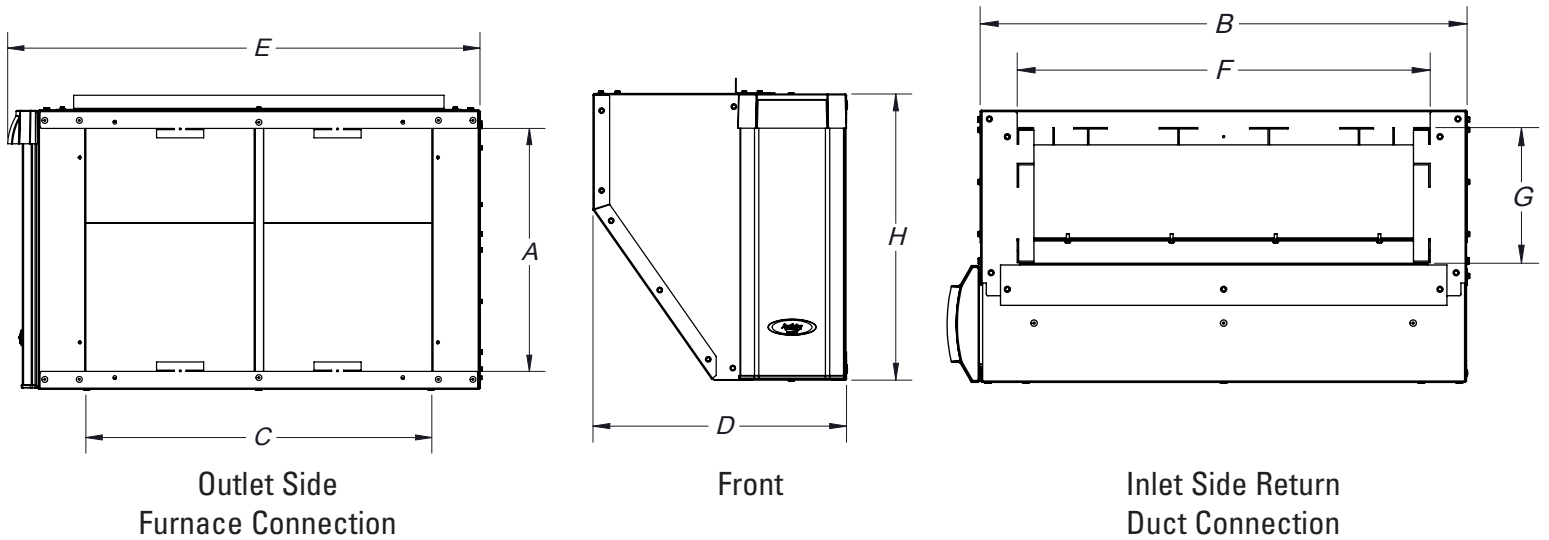

Dimension	Description	Model 1610
A	Outlet Opening Height	15.5"
B	Outer Housing Depth Without Door	28.2"
C	Outlet Opening Width	22.0"
D	Unit Width	15.7"
E	Outer Housing Depth With Door	30.1"
F	Inlet Opening Depth	24.1"
G	Inlet Opening Width	8.1" to 10.1"
H	Unit Height	17.8"

REPLACEMENT MEDIA		
MODEL 1610	APRILAIRE PART # 410	MERV 11
	APRILAIRE PART # 413	MERV 13



APRILAIRE RESERVES THE RIGHT TO CHANGE SPECIFICATIONS WITHOUT NOTICE.

PO Box 1467 • Madison, WI 53701-1467 • Phone 800/334-6011 • Fax 608/257-4357 • www.aprilairepartners.com