

Submittal

Dedicated Downflow Two Stage Condensing Gas Fired Furnace 120,000 BTUH

Downflow Only
S9V2D120D5PSBB

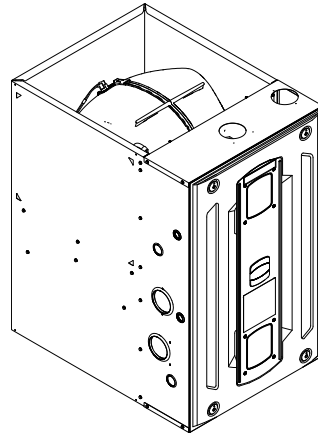

Note: Graphics in this document are for representation only. Actual model may differ in appearance.

Outline Drawings

Downflow Furnace D Size Cabinet

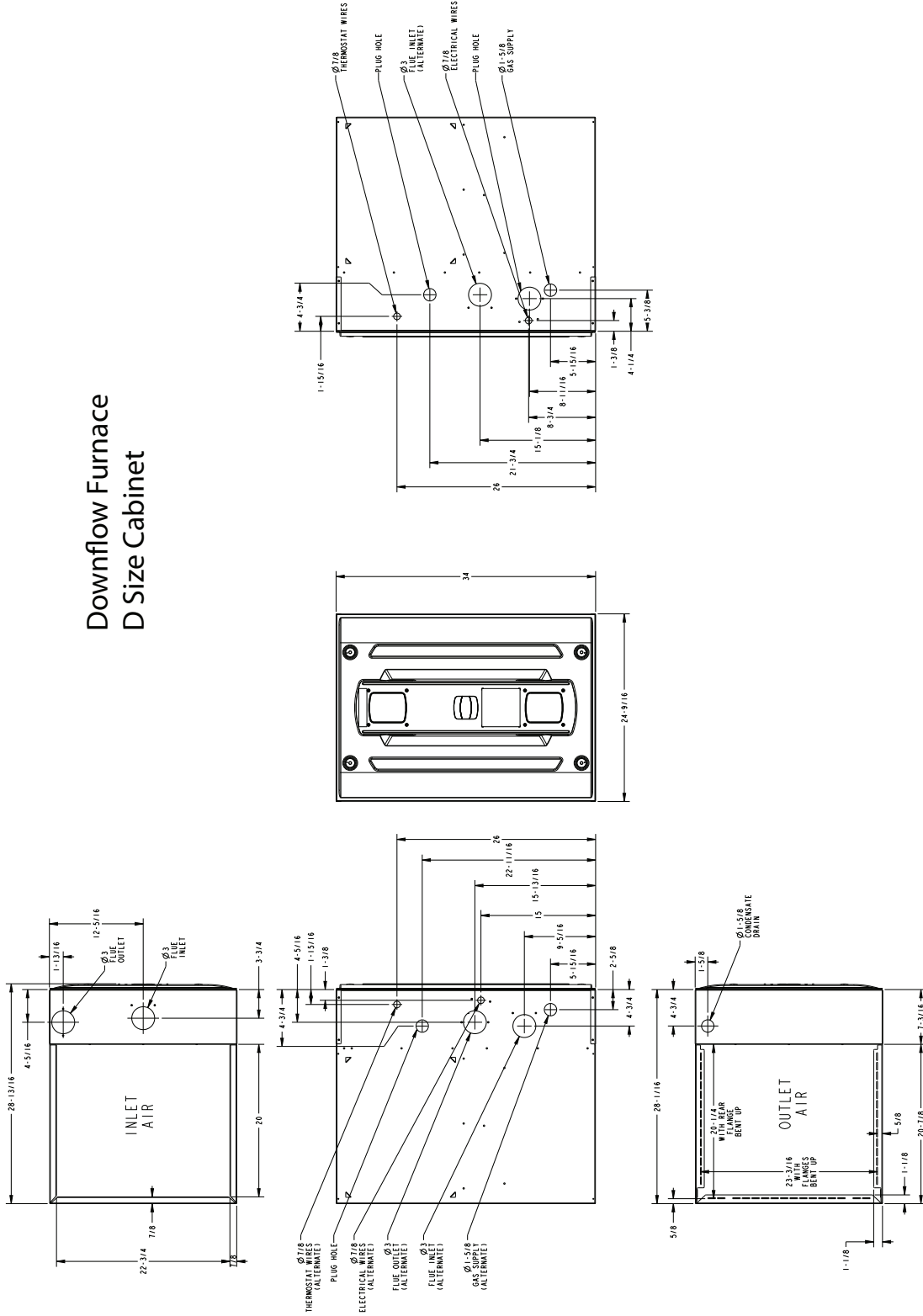

Product Specification

MODEL	S9V2D120D5PSBB (a)
TYPE	Downflow
RATINGS (b)	
1st Stage Input BTUH (ICS)	78,000
1st Stage Capacity BTUH	75,660
2nd Stage Input BTUH	120,000
2nd Stage Capacity BTUH (ICS) (c) (d)	116,400
1st Stage Temp. Rise (Min.-Max.)	35-65
2nd Stage Temp. Rise (Min.-Max.)	40-70
AFUE (%) (d)	96.0
BLOWER DRIVE	DIRECT
Diameter — Width (In.)	11 X 10
No. Used	1
Speeds (No.)	Variable
CFM vs. in. w.g.	See Fan Performance Table
Motor HP	1
RPM	Variable
Volts/Ph/Hz	120 / 1 / 60
FLA	10.5
COMBUSTION FAN — Type	Centrifugal
Drive — No. Speeds	Direct - 2
Motor HP — RPM	3300/2600
Volts/Ph/Hz	120 / 1 / 60
FLA	0.66
FILTER — Furnished?	No
Type recommended	High Velocity
Hi Vel. (No.-Size-Thk.)	2 — 16x20 — 1 in.
VENT PIPE DIAMETER — Min (in.) (e) (f)	3 Round
HEAT EXCHANGER	

MODEL	S9V2D120D5PSBB (a)
Type — Fired	409 Stainless Steel
— Unfired	29-4C Stainless Steel
Gauge (Fired)	20
ORIFICES — Main	
Nat. Gas Qty. — Drill Size	6 - 45
LP Gas Qty. — Drill Size	6- 56
GAS VALVE	Redundant - Two Stage
PILOT SAFETY DEVICE	
Type	120 V SiNi Igniter
BURNERS — Type	Multiport Inshot
Number	6
POWER CONN. — V/Ph/Hz (g)	120 / 1 / 60
Ampacity (In Amps)	13.9
Max. Overcurrent Protection (Amps)	15
PIPE CONN. SIZE (in.)	1/2
DIMENSIONS	H x W x D
Uncrated (In.)	34 x 24-1/2 x 28-3/4
Crated (In.)	35-1/2 x 26-1/2 x 30-7/8
WEIGHT	
Shipping (Lbs.)/Net (Lbs.)	167/156

(a) Meets Energy Star

(b) For U.S. applications, above input ratings (BTUH) are up to 2,000 feet, derate 4% per 1,000 feet for elevations above 2,000 feet above sea level. For Canadian applications, above input ratings (BTUH) are up to 4,500 feet, derate 4% per 1,000 feet for elevations above 4,500 feet above sea level.

(c) Central Furnace heating designs are certified to ANSI Z21.47 / CSA 2.3.

(d) Based on U.S. government standard tests.

(e) Refer to the Vent Length Table in the Installer's Guide.

(f) All S9V2 furnace models have a vent outlet diameter that equals 2 in.

(g) The above wiring specifications are in accordance with National Electrical Code; however, installations must comply with local codes.

Heating and Cooling Airflow Tables

Table 1. S9V2D120D5PSBB Heating Airflow

S9V2D120D5PSBB Furnace Heating Airflow (CFM) and Power (Watts) vs. External Static Pressure with Filter								
				1st Stage Capacity = 75,660				
				2nd Stage Capacity = 116,400				
Heating	Airflow Setting	Target Airflow		External Static Pressure				
				0.1	0.3	0.5	0.7	0.9
Heating 1st Stage	Low	1160	CFM	1234	1240	1246	1252	1258
			Temp. Rise	56	56	56	55	55
			Watts	137	198	258	319	380
	Medium Low	1332	CFM	1305	1311	1318	1325	1332
			Temp. Rise	53	53	53	52	52
			Watts	158	221	284	347	410
	Medium	1404	CFM	1324	1510	1697	1884	2070
			Temp. Rise	53	46	39	32	25
			Watts	179	246	313	380	447
	High ^(a)	1620	CFM	1598	1484	1371	1257	1144
			Temp. Rise	44	47	49	52	54
			Watts	266	316	366	416	466
Heating 2nd Stage	Low	1750	CFM	1687	1673	1659	1645	1631
			Temp. Rise	63	64	64	65	65
			Watts	327	407	487	568	648
	Medium Low	1850	CFM	1788	1771	1754	1738	1721
			Temp. Rise	60	60	61	61	62
			Watts	380	464	549	633	718
	Medium	1950	CFM	1891	1862	1833	1803	1774
			Temp. Rise	56	57	58	60	61
			Watts	424	524	624	724	824
	High ^(a)	2250	CFM	2080	2100	2120	2140	2160
			Temp. Rise	51	51	51	51	51
			Watts	708	768	828	888	948

^(a) Factory Setting.

Table 2. S9V2D120U5PSBB / S9V2D120D5PSBB Cooling Airflow

S9V2D120U5PSBB / S9V2D120D5PSBB Furnace Cooling Airflow (CFM) and Power (Watts) vs. External Static Pressure with Filter								
Cooling	Unit Outdoor	Airflow Setting (CFM/ton)		External Static Pressure				
				0.1	0.3	0.5	0.7	0.9
Cooling	3.5 Ton	Cooling 450 CFM/Ton	CFM	1575	1575	1575	1575	1575
			Watts	248	316	387	461	537
		Cooling 420 CFM/Ton	CFM	1470	1470	1470	1470	1470
			Watts	206	270	337	407	479
		Cooling 400 CFM/Ton	CFM	1400	1400	1400	1400	1400
			Watts	181	243	307	374	443
		Cooling 370 CFM/Ton	CFM	1295	1295	1295	1295	1295
			Watts	148	205	265	328	393
		Cooling 350 CFM/Ton	CFM	1225	1225	1225	1225	1225
			Watts	128	182	240	300	363
		Cooling 330 CFM/Ton	CFM	1155	1155	1155	1155	1155
			Watts	111	162	217	274	335
		Cooling 310 CFM/Ton	CFM	1085	1085	1085	1085	1085
			Watts	95	143	195	250	309
Cooling 290 CFM/Ton	CFM	1015	1015	1015	1015	1015		
	Watts	80	126	176	228	285		
Cooling	4.0 Ton	Cooling 450 CFM/Ton	CFM	1800	1800	1800	1800	1800
			Watts	356	433	514	597	682
		Cooling 420 CFM/Ton	CFM	1680	1680	1680	1680	1680
			Watts	295	368	443	521	601
		Cooling 400 CFM/Ton	CFM	1600	1600	1600	1600	1600
			Watts	258	328	400	475	552
		Cooling 370 CFM/Ton	CFM	1480	1480	1480	1480	1480
			Watts	210	274	342	412	484
		Cooling 350 CFM/Ton	CFM	1400	1400	1400	1400	1400
			Watts	181	243	307	374	443
		Cooling 330 CFM/Ton	CFM	1320	1320	1320	1320	1320
			Watts	155	213	274	338	405
		Cooling 310 CFM/Ton	CFM	1240	1240	1240	1240	1240
			Watts	132	187	245	306	369
Cooling 290 CFM/Ton	CFM	1160	1160	1160	1160	1160		
	Watts	112	163	218	276	337		
Cooling	4.5 Ton	Cooling 450 CFM/Ton	CFM	2025	2025	2025	2025	2025
			Watts	492	579	669	761	855
		Cooling 420 CFM/Ton	CFM	1890	1890	1890	1890	1890
			Watts	406	488	572	659	747
		Cooling 400 CFM/Ton	CFM	1800	1800	1800	1800	1800
			Watts	356	433	514	597	682
		Cooling 370 CFM/Ton	CFM	1665	1665	1665	1665	1665
			Watts	288	360	435	512	592
		Cooling 350 CFM/Ton	CFM	1575	1575	1575	1575	1575
			Watts	248	316	387	461	537
		Cooling 330 CFM/Ton	CFM	1485	1485	1485	1485	1485
			Watts	212	277	344	414	487
		Cooling 310 CFM/Ton	CFM	1395	1395	1395	1395	1395
			Watts	180	241	305	371	440
Cooling 290 CFM/Ton	CFM	1305	1305	1305	1305	1305		
	Watts	151	208	269	332	398		
Cooling	5.0 Ton ^(a)	Cooling 450 CFM/Ton	CFM	2250	2250	2250	2188	2103
			Watts	659	756	856	900	922
		Cooling 420 CFM/Ton	CFM	2100	2100	2100	2100	2100
			Watts	544	634	728	823	920
		Cooling 400 CFM/Ton	CFM	2000	2000	2000	2000	2000
			Watts	475	561	650	741	834
		Cooling 370 CFM/Ton	CFM	1850	1850	1850	1850	1850
			Watts	383	463	546	631	717
		Cooling 350 CFM/Ton ^(a)	CFM	1750	1750	1750	1750	1750
			Watts	329	405	484	564	647
		Cooling 330 CFM/Ton	CFM	1650	1650	1650	1650	1650
			Watts	281	352	427	503	582
		Cooling 310 CFM/Ton	CFM	1550	1550	1550	1550	1550
			Watts	237	305	375	448	523
Cooling 290 CFM/Ton	CFM	1450	1450	1450	1450	1450		
	Watts	199	262	328	397	468		

^(a) Factory Setting

General Features

NATURAL GAS MODELS

Central Heating furnace designs are certified by the American Gas Association for both natural and L.P. gas. Limit setting and rating data were established and approved under standard rating conditions using American National Standards Institute standards.

SAFE OPERATION

The Integrated System Control is a solid state device which continuously monitors for presence of flame when the system is in the heating mode of operation. Dual solenoid combination gas valve and regulator provide additional safety.

QUICK HEATING

Durable, cycle tested, heavy gauge **tubular stainless steel primary heat exchanger** quickly transfers heat to provide warm conditioned air to the structure. **Low energy power vent blower**, to increase efficiency and provide a positive discharge of gas fumes to the outside.

BURNERS

Multiport Inshot burners will give years of quiet and efficient service. All models can be converted to **L.P. gas** with LP conversion kit.

INTEGRATED SYSTEM CONTROL

Exclusively designed operational program provides total control of furnace limit sensors, blowers, gas valve, flame control and includes self diagnostics for ease of service. Also contains dry contacts for EAC and HUM.

ENERGY EFFICIENT OPERATION

Furnace is certified by the manufacturer to leak 1% or less of nominal air conditioning CFM delivered when pressurized to .5" water column with all inlets, outlets, and drains sealed.

AIR DELIVERY

The variable speed blower motor has sufficient airflow for most heating and cooling requirements and will switch from heating to cooling speeds on demand from room thermostat.

SECONDARY HEAT EXCHANGER

The S-Series furnace has a special type 29- 4C™ stainless steel secondary heat exchanger to reclaim heat from flue gases which would normally be lost.

STYLING

Heavy gauge steel and "wrap-around" cabinet construction is used in the cabinet with baked-on enamel finish for strength and beauty. Every orientation has at least two venting options. There are no knockouts on cabinet.

FEATURES AND GENERAL OPERATION

The S-Series furnace utilizes a Silicon Nitride Hot Surface Ignition system, which eliminates the waste of a constant burning pilot. The integrated system control lights the main burners upon a demand for heat from the room thermostat. Complete front service access.

- a. Low energy power venter
- b. Vent proving pressure switches.

Features and Benefits

96.0% AFUE ACROSS ALL MODELS

Meets utility rebates

Lowers utility bills

ELECTRICALLY EFFICIENT

Efficient airflow design reduces electrical energy use

34 INCH TALL

Lighter, easier to move and fit into tight spaces like short basements or tight closets

Works great with larger, high-efficiency coils

No knockouts

3-WAY MULTI-POISE / DEDICATED DOWNFLOW

8 SKU's — Upflow / Horizontal Left / Horizontal Right

6 SKU's — Downflow

Added application flexibility and reduction in specification errors

AIRFLOW

At least 400 CFM/ton at 0.5 in. H₂O external static pressure; setup airflow options down to 290 CFM/ton

REGULATORY

All models are air tight; 1% or less air leakage as per ASHRAE 193

Open vestibule design provides a full 34" high open vestibule

DIMENSIONS

Widths are industry standard: 17.5", 21", and 24.5"

Depth remains approximately 28"

Cabinet will be compatible with industry standard coils, as well as, other accessories

INTEGRATED FURNACE CONTROL

Setup / Status / Diagnostics / Digital Display

No dip switches

Last six errors stored

Dry contact EAC and HUM connections

All Molex connections; no spade terminals

Low voltage labeled above and below

Rain shield over IFC keeps condensate off the control

TUBULAR STAINLESS STEEL PRIMARY HEAT EXCHANGER

29-4C STAINLESS STEEL SECONDARY HEAT EXCHANGER

Stainless steel is a more durable, corrosive-resistant material than aluminized steel

Integrated rail system for easy access if required

Reduces or eliminates need for baffles

VORTICA II BLOWER, DESIGNED EXCLUSIVELY FOR THE S-SERIES FURNACE

Improved airflow efficiency

Durable, easy to clean, two piece housing

Single piece belly band/ motor arm assembly

Blower deck has full-length rails for easy removal and replacement, regardless of poise

THREE-WAY MULTI-POISE (UPFLOW, HORIZONTAL LEFT AND RIGHT) PLUS DEDICATED DOWNFLOW

Easier to specify

Shipped ready to install (no kits required)

Every model has at least two venting options

When in horizontal, trap extends only about 2"

Barbed fitting on trap at hose connection and on cabinet transition for hose has barbed fitting and clamps at both ends for leak resistance.

Vent table improvements including longer vent lengths; 2" pipe can be used up to 100K

About Trane and American Standard Heating and Air Conditioning

Trane and American Standard create comfortable, energy efficient indoor environments for residential applications. For more information, please visit www.trane.com or www.americanstandardair.com.



The manufacturer has a policy of continuous data improvement and it reserves the right to change design and specifications without notice. We are committed to using environmentally conscious print practices.