

Submittal

Dedicated Downflow Two Stage Condensing Gas Fired Furnace 60,000 BTUH

Downflow Only
S9X2B060D3PSBA

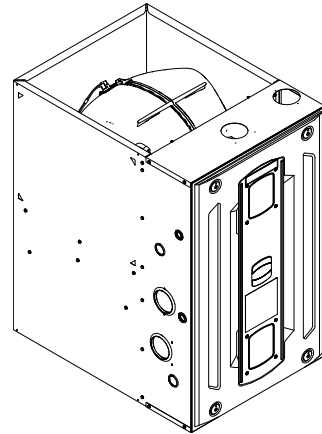

Note: Graphics in this document are for representation only. Actual model may differ in appearance.

Outline Drawings

Table 1. 17.5" Downflow Cabinet

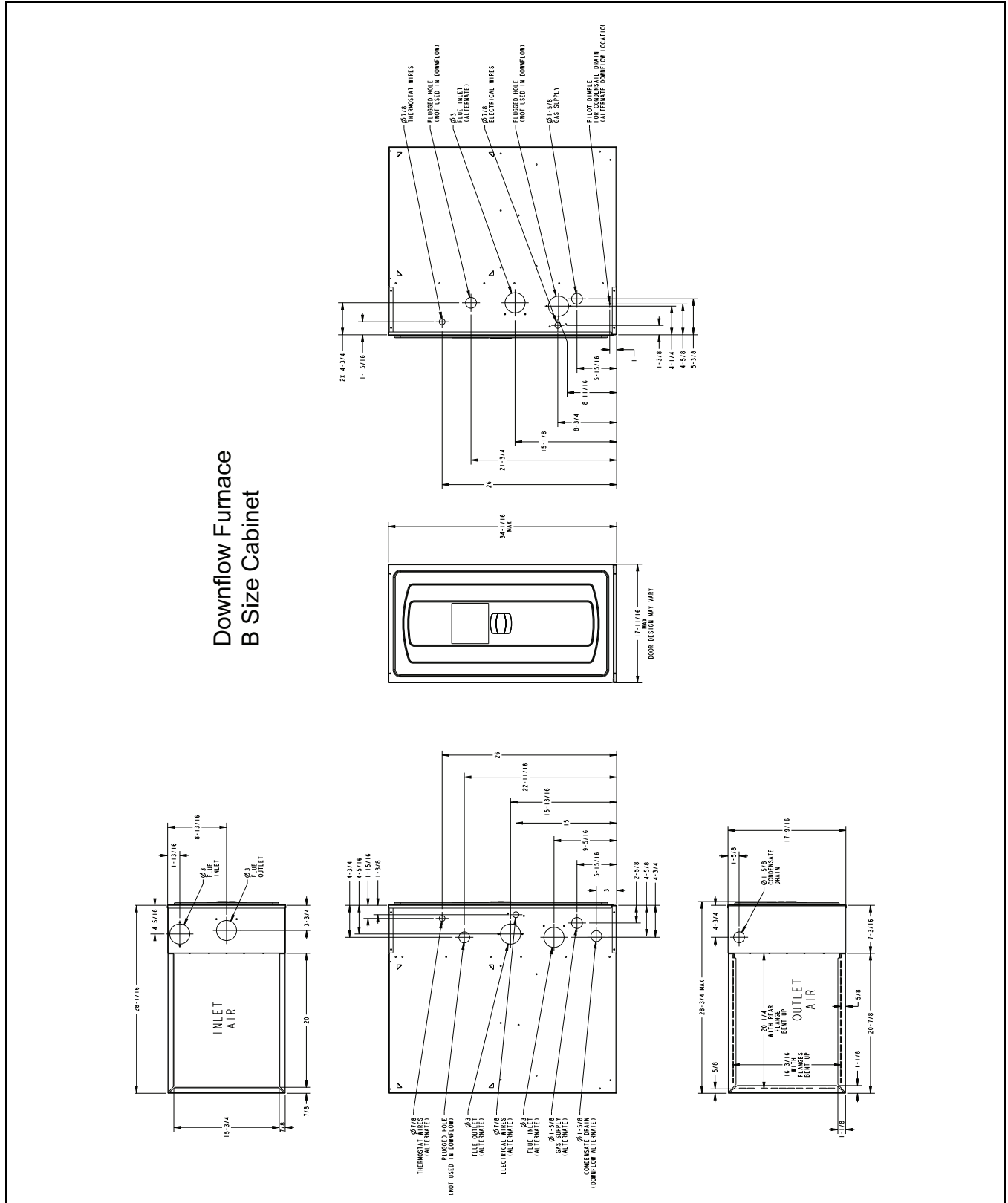

Product Specifications

MODEL	S9X2B060D3PSBA (a)
TYPE	Downflow
RATINGS (b)	
1st Stage Input BTUH (ICS)	39,000
1st Stage Capacity BTUH	37,830
2nd Stage Input BTUH	60,000
2nd Stage Capacity BTUH (ICS) (c) (d)	57,600
1st Stage Temp. Rise (Min.-Max.)	25 - 55
2nd Stage Temp. Rise (Min.-Max.)	35 - 65
AFUE (%)	95.0
Return Air Temp. (Min. - Max.)	45°F - 80°F
BLOWER DRIVE	DIRECT
Diameter — Width (In.)	11 X 8
No. Used	1
Speeds (No.) (e)	9
CFM vs. in. w.g.	See Fan Performance Table
Motor HP	1/2
RPM	1075
Volts/Ph/Hz	120 / 1 / 60
FLA	6.4
COMBUSTION FAN — Type	Centrifugal
Drive — No. Speeds	Direct - 2
Motor HP — RPM	3300/2600
Volts/Ph/Hz	120 / 1 / 60
FLA	0.66
FILTER — Furnished?	No
Type recommended	High Velocity
Hi Vel. (No.-Size-Thk.)	2 — 14x20 — 1 in.
VENT PIPE DIAMETER — Min (in.) (f) (g)	2 Round
HEAT EXCHANGER	

MODEL	S9X2B060D3PSBA (a)
Type — Fired	409 Stainless Steel
— Unfired	29-4C Stainless Steel
Gauge (Fired)	20
ORIFICES — Main	
Nat. Gas Qty. — Drill Size	3 - 45
LP Gas Qty. — Drill Size	3 - 56
GAS VALVE	Redundant - Two Stage
PILOT SAFETY DEVICE	
Type	120 V SiNi Igniter
BURNERS — Type	Multiport Inshot
Number	3
POWER CONN. — V/Ph/Hz (h)	120 / 1 / 60
Ampacity (In Amps)	8.8
Max. Overcurrent Protection (Amps)	15
PIPE CONN. SIZE (in.)	1/2
DIMENSIONS	H x W x D
Uncrated (In.)	34 x 17-1/2 x 28-3/4
Crated (In.)	35-1/2 x 19-1/2 x 30-7/8
WEIGHT	
Shipping (Lbs.)/Net (Lbs.)	127/119

(a) Meets Energy Star

(b) For U.S. applications, above input ratings (BTUH) are up to 2,000 feet, derate 4% per 1,000 feet for elevations above 2,000 feet above sea level. For Canadian applications, above input ratings (BTUH) are up to 4,500 feet, derate 4% per 1,000 feet for elevations above 4,500 feet above sea level.

(c) Central Furnace heating designs are certified to ANSI Z21.47 / CSA 2.3.

(d) Based on U.S. government standard tests.

(e) 9 Speed constant torque ECM blower motor

(f) Refer to the Vent Length Table in the Installer's Guide.

(g) All S9X2 furnace models have a vent outlet diameter that equals 2 in.

(h) The above wiring specifications are in accordance with National Electrical Code; however, installations must comply with local codes.

Airflow tables

Furnace Airflow (CFM) Vs. External Static Pressure (in. W.C.)							
Model	Tap		0.1	0.3	0.5	0.7	0.9
S9X2B060D3PSBA	1	SCFM	624	451	277	104	-
		Watts	47	57	68	79	-
	2	SCFM	866	734	602	470	338
		Watts	89	102	116	129	142
	3	SCFM	949	833	718	602	486
		Watts	113	128	142	156	171
	4	SCFM	1122	1025	928	831	733
		Watts	165	182	200	217	235
	5	SCFM	1178	1087	996	905	814
		Watts	191	209	227	246	264
	6	SCFM	1260	1180	1100	1021	941
		Watts	233	252	271	290	309
	7	SCFM	1370	1299	1228	1158	1087
		Watts	296	316	336	355	375
	8	SCFM	1480	1416	1352	1287	1223
		Watts	365	387	408	429	450
	9	SCFM	1504	1440	1376	1312	1249
		Watts	384	406	427	449	470

CFM Versus Temperature Rise

Table 2. 2nd Stage Heating Table – Downflow

CFM VS. 2ND STAGE TEMPERATURE RISE											
MODEL	CFM (CUBIC FEET PER MINUTE)										
	800	900	1000	1100	1200	1300	1400	1500	1600	1700	1800
S9X2B060D3PSBA		60	54	49	45	41	38	36			

Table 3. 1st Stage Heating Table – Downflow

CFM VS. 1ST STAGE TEMPERATURE RISE																		
MODEL	CFM (CUBIC FEET PER MINUTE)																	
	400	500	600	700	800	900	1000	1100	1200	1300	1400	1500	1600	1700	1800	1900	2000	2100
S9X2B060D3PSBA				50	44	39	35	32	29	27	25							

General Features

NATURAL GAS MODELS

Central Heating furnace designs are certified by the American Gas Association for both natural and L.P. gas. Limit setting and rating data were established and approved under standard rating conditions using American National Standards Institute standards.

SAFE OPERATION

The Integrated System Control is a solid state device which continuously monitors for presence of flame when the system is in the heating mode of operation. Dual solenoid combination gas valve and regulator provide additional safety.

QUICK HEATING

Durable, cycle tested, heavy gauge **tubular stainless steel primary heat exchanger** quickly transfers heat to provide warm conditioned air to the structure. **Low energy power vent blower**, to increase efficiency and provide a positive discharge of gas fumes to the outside.

BURNERS

Multiport Inshot burners will give years of quiet and efficient service. All models can be converted to **L.P. gas** with LP conversion kit.

INTEGRATED SYSTEM CONTROL

Exclusively designed operational program provides total control of furnace limit sensors, blowers, gas valve, flame control and includes self diagnostics for ease of service. Also contains dry contacts for EAC and HUM.

ENERGY EFFICIENT OPERATION

Furnace is certified by the manufacturer to leak 1% or less of nominal air conditioning CFM delivered when pressurized to .5" water column with all inlets, outlets, and drains sealed.

AIR DELIVERY

The 9 speed blower motor has sufficient airflow for most heating and cooling requirements and will switch from heating to cooling speeds on demand from room thermostat.

SECONDARY HEAT EXCHANGER

The S-Series furnace has a special type 29- 4C™ stainless steel secondary heat exchanger to reclaim heat from flue gases which would normally be lost.

STYLING

Heavy gauge steel and "wrap-around" cabinet construction is used in the cabinet with baked-on enamel finish for strength and beauty. Every orientation has at least two venting options. There are no knockouts on cabinet.

FEATURES AND GENERAL OPERATION

The S-Series furnace utilizes a Silicon Nitride Hot Surface Ignition system, which eliminates the waste of a constant burning pilot. The integrated system control lights the main burners upon a demand for heat from the room thermostat. Complete front service access.

- a. Low energy power venter
- b. Vent proving pressure switches.

Features and Benefits

UP TO 96.0% AFUE ON S9X2 FURNACE MODELS

Meets utility rebates

Lowers utility bills

ELECTRICALLY EFFICIENT

Efficient airflow design reduces electrical energy use

34 INCH TALL

Lighter, easier to move and fit into tight spaces like short basements or tight closets

Works great with larger, high-efficiency coils

No knockouts

3-WAY MULTI-POISE / DEDICATED DOWNFLOW

6 SKU's — Upflow / Horizontal Left / Horizontal Right

5 SKU's — Downflow

Added application flexibility and reduction in specification errors

AIRFLOW

At least 400 CFM/ton at 0.5 in. H₂O external static pressure

REGULATORY

All models are air tight; 1% or less air leakage as per ASHRAE 193

Open vestibule design provides a full 34" high open vestibule

DIMENSIONS

Widths are industry standard: 17.5", 21", and 24.5"

Depth remains approximately 28"

Cabinet will be compatible with industry standard coils, as well as, other accessories

INTEGRATED FURNACE CONTROL

Setup / Status / Diagnostics / Digital Display

No dip switches

Last six errors stored

Dry contact EAC and HUM connections

All Molex connections; no spade terminals

Low voltage labeled above and below

Rain shield over IFC keeps condensate off the control

TUBULAR STAINLESS STEEL PRIMARY HEAT EXCHANGER

29-4C STAINLESS STEEL SECONDARY HEAT EXCHANGER

Stainless steel is a more durable, corrosive-resistant material than aluminized steel

Integrated rail system for easy access if required

Reduces or eliminates need for baffles

VORTICA II BLOWER, DESIGNED EXCLUSIVELY FOR THE S-SERIES FURNACE

Improved airflow efficiency

Durable, easy to clean, two piece housing

Single piece belly band/ motor arm assembly

Blower deck has full-length rails for easy removal and replacement, regardless of poise

THREE-WAY MULTI-POISE (UPFLOW, HORIZONTAL LEFT AND RIGHT) PLUS DEDICATED DOWNFLOW

Easier to specify

Shipped ready to install (no conversion kits required)

Every model has at least two venting options

When in horizontal, trap extends only about 2"

Barbed fitting on trap at hose connection and on cabinet transition for hose has barbed fitting and clamps at both ends for leak resistance.

Vent table improvements including longer vent lengths; 2" pipe can be used up to 100K

About Trane and American Standard Heating and Air Conditioning

Trane and American Standard create comfortable, energy efficient indoor environments for residential applications. For more information, please visit www.trane.com or www.americanstandardair.com.



The manufacturer has a policy of continuous data improvement and it reserves the right to change design and specifications without notice. We are committed to using environmentally conscious print practices.