

# Submittal

## Variable Speed Convertible Air Handler 3 Ton

TEM6A0C36H31SC

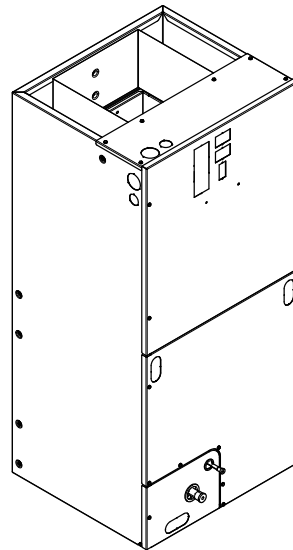

**Note:** The TEM6 series air handler is designed for installation in a closet, utility room, alcove, basement, crawlspace or attic. These versatile units are applicable to air conditioning and heat pump applications. Several models are available to meet the specific requirements of the outdoor equipment. Field installed electric resistance heaters are available.

# Outline Drawing

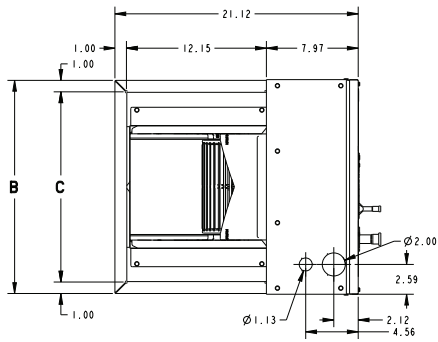

MINIMUM UNIT CLEARANCE TABLE	
	SERVICE CLEARANCE (RECOMMENDED)
SIDES	2"
FRONT	21"
BACK	0"
INLET DUCT	1"
OUTLET DUCT	N/A

NOTE: THIS UNIT IS APPROVED FOR INSTALLATION CLEARANCES TO COMBUSTIBLE MATERIAL AS STATED ON THE UNIT RATING NAMEPLATE

ALL DIMENSIONS ARE REFERENCE DIMENSIONS

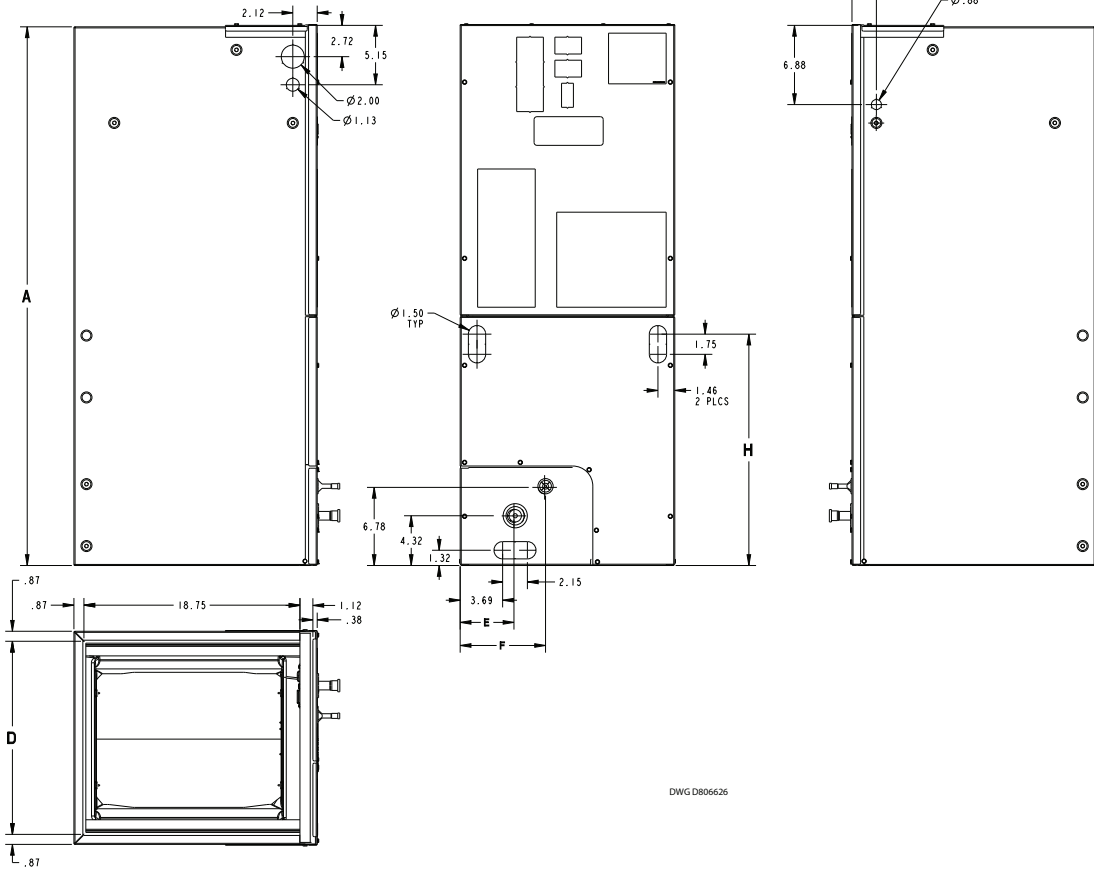

DWG D806626

PRODUCT DIMENSIONS									
Air Handler Model	A	B	C	D	E	F	H	Flow Control	Gas Line Braze
TEM6A0C36H31SC	51.27	23.50	21.50	21.75	7.01	9.66	24.59	TXV	7/8
All dimensions are in inches									

# Product Specifications

<b>MODEL</b>	TEM6A0C36H31SC
<b>RATED VOLTS/PH/HZ</b>	208-230/1/60
<b>RATINGS<sup>(a)</sup></b>	See O.D. Specifications
<b>INDOOR COIL — Type</b>	Plate Fin
Rows — F.P.I.	4 - 14
Face Area (sq. ft.)	4.59
Tube Size (in.)	3/8
Refrigerant Control	TXV
Drain Conn. Size (in.) <sup>(b)</sup>	3/4 NPT
<b>DUCT CONNECTIONS</b>	<b>See Outline Drawing</b>
<b>INDOOR FAN — Type</b>	Centrifugal
Diameter-Width (In.)	11 X 8
No. Used	1
Drive - No. Speeds	Direct - 16
CFM vs. in. w.g.	See Fan Performance Table
No. Motors — H.P.	1 - 1/2
Motor Speed R.P.M.	Variable
Volts/Ph/Hz	208-230/1/60

F.L. Amps	4.3
<b>FILTER</b>	
Filter Furnished? <sup>(c)</sup>	No
<b>REFRIGERANT</b>	<b>R-410A</b>
Ref. Line Connections	Brazed
Coupling or Conn. Size — in. Gas	7/8
Coupling or Conn. Size — in. Liq.	3/8
<b>DIMENSIONS</b>	H x W x D
Crated (In.)	52-3/4 x 27-1/2 x 25-1/2
Uncrated	51-3/8 x 23-1/2 x 21-1/8
<b>WEIGHT</b>	
Shipping (Lbs.) / Net (Lbs.)	155/144

<sup>(a)</sup> These Air Handlers are A.H.R.I certified with various Split System Air Conditioners and Heat Pumps (AHRI STANDARD 210/240). Refer to the Split System Outdoor Unit Product Data Guides for performance data.

<sup>(b)</sup> 3/4" Male Plastic Pipe (Ref: ASTM 1785-76)

<sup>(c)</sup> Remote filter required.

# Minimum Airflow CFM

TEM6A0C36H31SC		
Heater	Minimum Heater Airflow CFM	
	With Heat Pump	Without Heat Pump
BAYHTR1504BRK, BAYHTR1504LUG BAYHTR1505BRK, BAYHTR1505LUG	875	675
BAYHTR1508BRK, BAYHTR1508LUG	950	820
BAYHTR1510BRK, BAYHTR1510LUG	1000	820
BAYHTR1517BRK	1000	820
BAYHTR3510LUG	875	820
BAYHTR3517LUG	1000	950
BAYHTR1523BRK	1300	1140

TEM6A0C36H31SBC Airflow Performance with Auxiliary Heat				
Airflow Settings	Dip Switch Settings		Nominal Airflow	See following tables for heater application: - Pressure Drop for Electrical Heaters - Minimum Heating Airflow Matrix (on unit nameplates)
	Switch 7	Switch 8		
Low	ON	ON	696	
Med-Lo	OFF	ON	825	
Med-Hi	ON	OFF	1150	
High	OFF	OFF	1298	

# Heater Pressure Drop Table

Airflow CFM	Number of Racks				Heater Racks	
	1	2	3	4	Heater Model	No. of Racks
	Air Pressure Drop — Inches W.G.					
1800	0.02	0.04	0.06	0.14	BAYHTR1504	1
1700	0.02	0.04	0.06	0.14	BAYHTR1505	1
1600	0.02	0.04	0.06	0.13	BAYHTR1508	2
1500	0.02	0.04	0.06	0.12	BAYHTR1510	2
1400	0.02	0.04	0.06	0.12	BAYHTR1517	3
1300	0.02	0.04	0.05	0.11	BAYHTR3510	3
1200	0.01	0.04	0.05	0.10	BAYHTR3517	3
1100	0.01	0.03	0.05	0.09	BAYHTR1523	4
1000	0.01	0.03	0.04	0.09	BAYHTR1525	4
900	0.01	0.03	0.04	0.08		
800	0.01	0.03				
700	0.01	0.02				
600	0.01	0.02				

## Subcooling Adjustment

System Matched with:	Indoor Unit Model No.	Outdoor Model No.	Subcooling
16 SEER HP — 2 ton	TEM6A0C36H31	4TWR6024H1000A 4TWX6024H1000A 4A6H6024H1000A	13 Degrees
15 SEER HP — 2 ton	TEM6A0B24H21 TEM6A0B30H21	4TWR5024G1000A 4A6H5024G1000A	14 Degrees
15 SEER HP — 3 ton	TEM6A0B30H21 TEM6A0C36H31 TEM6A0C42H41	4TWR5036G1000A 4A6H5036G1000A	14 Degrees
All other matches must be charged per the nameplate charging instructions			

# Performance and Electrical Data

**Table 1. Air Flow Performance**

TEM6A0C36H31SC, TEM6A0C42H41SC COOLING AIRFLOW PERFORMANCE, WET COIL, NO FILTER, NO HEATER												
OUTDOOR UNIT SIZE (TONS)	SPEED SETTING	AIRFLOW SETTING	DIP SWITCH SETTING				AIRFLOW POWER	EXTERNAL STATIC PRESSURE				
			SW1	SW2	SW3	SW4		0.1	0.3	0.5	0.7	0.9
2.5	LOW	300 CFM/ton	ON	ON	OFF	ON	CFM Watts	761 63	755 98	719 131	654 163	560 193
	NORMAL	341 CFM/ton	ON	ON	OFF	OFF	CFM Watts	862 82	861 120	834 158	781 196	700 235
	HIGH	384 CFM/ton	ON	ON	ON	OFF	CFM Watts	962 106	963 147	948 190	915 234	863 279
3	LOW	319 CFM/ton	OFF	ON	OFF	ON	CFM Watts	961 106	962 147	947 189	914 233	862 279
	NORMAL	363 CFM/ton	OFF	ON	OFF	OFF	CFM Watts	1092 146	1093 192	1082 240	1060 288	1026 337
	HIGH	408 CFM/ton	OFF	ON	ON	OFF	CFM Watts	1231 196	1231 249	1221 301	1203 353	1175 404
3.5	LOW	315 CFM/ton	ON	OFF	OFF	ON	CFM Watts	1104 150	1105 197	1094 245	1072 293	1039 343
	NORMAL	357 CFM/ton	ON	OFF	OFF	OFF	CFM Watts	1258 209	1258 263	1248 317	1229 369	1201 421
	HIGH	402 CFM/ton	ON	OFF	ON	OFF	CFM Watts	1418 286	1415 347	1401 406	1379 462	1348 516
4	LOW	308 CFM/ton	OFF	OFF	OFF	ON	CFM Watts	1238 199	1238 253	1229 306	1210 357	1182 408
	NORMAL <sup>(a)</sup>	350 CFM/ton	OFF	OFF	OFF	OFF	CFM Watts	1412 282	1410 344	1398 404	1378 462	1349 517
	HIGH	394 CFM/ton	OFF	OFF	ON	OFF	CFM Watts	1570 393	1528 436	1473 466	1406 483	1326 488

<sup>(a)</sup> Factory Default Setting

**Table 2. Air Flow Performance**

TEM6A0C36H31SC, TEM6A0C42H41SC HEATING AIRFLOW PERFORMANCE, NO FILTER, NO HEATER												
OUTDOOR UNIT SIZE (TONS)	SPEED SETTING	AIRFLOW SETTING	DIP SWITCH SETTING				AIRFLOW POWER	EXTERNAL STATIC PRESSURE				
			SW1	SW2	SW3	SW4		0.1	0.3	0.5	0.7	0.9
2.5	LOW	341 CFM/ton	ON	ON	OFF	ON	CFM Watts	860 77	863 115	838 154	788 193	707 232
	NORMAL	379 CFM/ton	ON	ON	OFF	OFF	CFM Watts	949 98	953 138	937 180	906 224	852 269
	HIGH	417 CFM/ton	ON	ON	ON	OFF	CFM Watts	1042 122	1046 166	1036 212	1015 259	980 308
3	LOW	381 CFM/ton	OFF	ON	OFF	ON	CFM Watts	1147 154	1149 203	1141 253	1123 303	1094 353
	NORMAL	424 CFM/ton	OFF	ON	OFF	OFF	CFM Watts	1277 204	1279 259	1272 314	1255 368	1228 421
	HIGH	466 CFM/ton	OFF	ON	ON	OFF	CFM Watts	1409 260	1409 323	1401 383	1384 442	1357 500
3.5	LOW	348 CFM/ton	ON	OFF	OFF	ON	CFM Watts	1222 180	1224 232	1216 285	1200 336	1174 388
	NORMAL	386 CFM/ton	ON	OFF	OFF	OFF	CFM Watts	1361 240	1362 300	1354 358	1337 415	1310 471
	HIGH	425 CFM/ton	ON	OFF	ON	OFF	CFM Watts	1497 316	1478 372	1449 420	1408 461	1356 494
4	LOW	338 CFM/ton	OFF	OFF	OFF	ON	CFM Watts	1360 239	1361 299	1353 358	1336 415	1309 470
	NORMAL <sup>(a)</sup>	375 CFM/ton	OFF	OFF	OFF	OFF	CFM Watts	1511 325	1489 380	1456 426	1412 464	1355 493
	HIGH	413 CFM/ton	OFF	OFF	ON	OFF	CFM Watts	1659 420	1605 463	1535 488	1450 494	1349 483

<sup>(a)</sup> Factory Default Setting

1. See Product Data or Air Handler nameplate for approved combinations of Air Handlers and Heaters.
2. Heater model numbers may have additional suffix digits.

**Table 3. Electrical Data**

<b>TEM6A0C36H31SC, TEM6A0C42H41SC HEATER DATA</b>											
Heater Model No.	No. of Circuits/ Phases	240 Volt					208 Volt				
		Capacity		Heater Amps per Circuit	Minimum Circuit Ampacity	Maximum Overload Protection	Capacity		Heater Amps per Circuit	Minimum Circuit Ampacity	Maximum Overload Protection
		kW	BTUH				kW	BTUH			
No Heater				4.3 *	5	15			4.3 *	5	15
BAYHTR1504BRK BAYHTR1504LUG	1/1	3.84	13100	16.0	25	25	2.88	9800	13.8	23	25
BAYHTR1505BRK BAYHTR1505LUG	1/1	4.80	16400	20.0	30	30	3.60	12300	17.3	27	30
BAYHTR1508BRK BAYHTR1508LUG	1/1	7.68	26200	32.0	45	45	5.76	19700	27.7	40	40
BAYHTR1510BRK BAYHTR1510LUG	1/1	9.60	32800	40.0	55	60	7.20	24600	34.6	49	50
BAYHTR1517BRK Circuit 1 <sup>(a)</sup>	2/1	9.60	32800	40.0	55	60	7.20	24600	34.6	49	50
BAYHTR1517BRK Circuit 2		4.80	16400	20.0	25	25	3.60	12300	17.3	22	25
BAYHTR1523BRK Circuit 1	2/1	9.60	32800	40.0	55	60	7.20	24600	34.6	49	50
BAYHTR1523BRK Circuit 2		9.60	32800	40.0	50	50	7.20	24600	34.6	43	45
BAYHTR3510LUG	1/3	9.60	32800	23.1	34	35	7.20	24600	20.0	30	30
BAYHTR3517LUG	1/3	14.40	49100	34.6	48	50	10.80	36900	30.0	42	45

\* = Motor Amps

<sup>(a)</sup> MCA and MOP for circuit 1 contains the motor amps

## Features and Benefits

- Painted metal cabinet with captured foil face insulation
- 2% or less air leakage
- R-4.2 Insulating Value
- Multi-Position UP/Down Flow, Horizontal Left /Right
- ALL Aluminum Coil
- Electric Heaters with polarized plug connections (sold as accessory)
- R-410A Thermal Expansion Valve
- Variable Speed ECM Motor
- Low Voltage Pigtail Connections
- Draw Through Design
- Horizontal Drain Pan
- Single Color
- Fused 24V Power
- **3 year warranty**
- **10-year warranty registered**
- **Optional extended warranty available**

## About Trane and American Standard Heating and Air Conditioning

Trane and American Standard create comfortable, energy efficient indoor environments for residential applications. For more information, please visit [www.trane.com](http://www.trane.com) or [www.americanstandardair.com](http://www.americanstandardair.com).

---



The manufacturer has a policy of continuous data improvement and it reserves the right to change design and specifications without notice. We are committed to using environmentally conscious print practices.

TEM6A0C36-SUB-1E-EN 09 Mar 2022

Supersedes TEM6A0C36-SUB-1D-EN (April 2020)

©2022