

M-6140 1

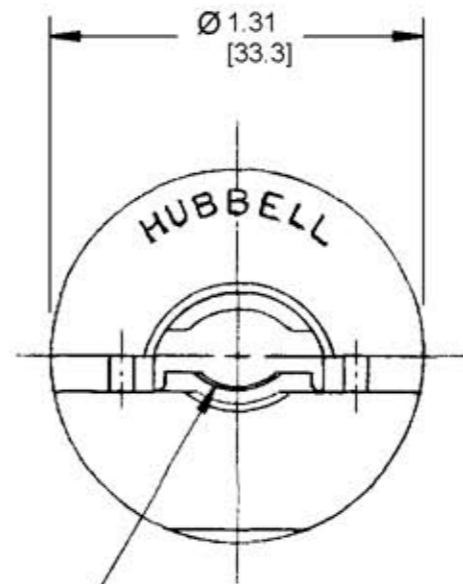
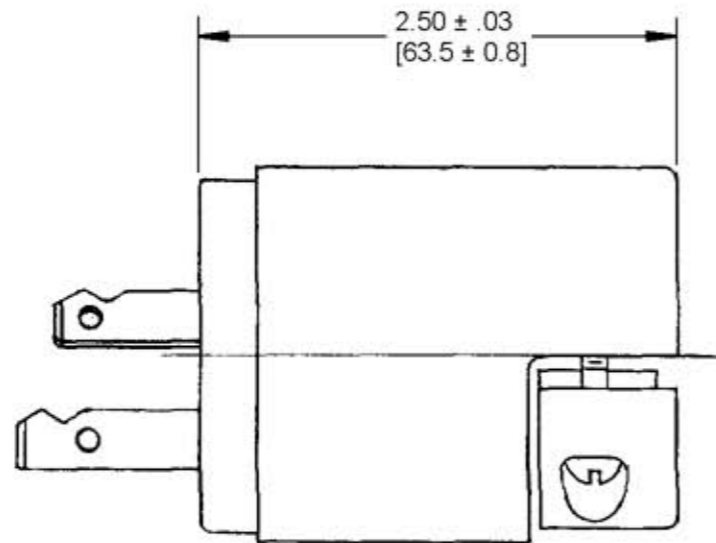

CORD CLAMP TAKES CORDS FROM .39 [9.9] TO .84 [21.4]

NOTES: (UNLESS OTHERWISE SPECIFIED)

1) DIMENSION FORMAT IS: INCHES [mm]

2) DIMENSIONS SHOWN ON THIS DRAWING ARE NOMINAL VALUES FOR GENERAL USE ONLY. ACTUAL PART TOLERANCES MUST BE OBTAINED FROM HUBBELL ENGINEERING.

LIST OF PARTS

DESCRIPTION	MATERIAL	FINISH
BLADE HOLDER	NYLON	NATURAL
RETAINING SHELL	LEXAN	NATURAL
CONTACT BLADES	1/15 BRASS	1-WHITE
BINDING SCREWS	BRASS	
WIRE NUTS	.062 STEEL	NICKEL PL
COVER	NYLON	BLACK
CORD CLAMP	NYLON	NATURAL

DIMENSION SHEET FOR CAT. NO. HBL9977C

REPAIRABLE NON-REPAIRABLE

SYM	REVISIONS	APP	DATE
1	TRI-DRIVE SCREWS WERE SLOTTED; DUAL DIMENSIONS WERE FRACTIONAL ONLY; REVISED DRAWING TITLE; ADDED NOTES; HBL9977C WAS 9977-C; PER DCN #8682. JMN	TCM	12/5/01

B M-6140

TITLE
20A. 125/250V. STRAIGHT BLADE PLUG
NEMA 10-20P

TOLERANCES UNLESS OTHERWISE SPECIFIED
FRACTIONS ± 1/64
DECIMALS ± .005
ANGLES ± 2°

HARVEY HUBBELL, INC.
BRIDGEPORT, CONN.

DR. BY A.J.L. APP. BY _____
TR. BY _____ SCALE FULL
CHK'D. BY _____ DATE 5-5-78