

MYERS® MSCI Series

Heavy Duty Cast Iron Submersible Sump Pumps

SPECIFICATIONS

Applications	Basement sumps dewatering	
Capacities		
MSCI33	72 GPM	272 LPM
MSCI50	87 GPM	329 LPM
Shut-off head		
MSCI33	22'	6.70 m
MSCI50	29'	8.84 m
Operation:		
Tethered: On	13-1/2"	343 mm
Off	4-1/2"	114 mm
Vertical: On	7-1/2"	190.5 mm
Off	3"	76 mm
Diaphragm: On	9"	228.6 mm
Off	4-1/2"	114 mm
Solids handling	3/8"	9.6 mm
Intermittent liquid temp	32°F to 70°F	0°C-21°C
Motor	PSC Motor	
Electrical data	115V, 60 HZ., 15 Amp Circuit	
Individual Branch Circuit Required (min.)	15 Amps.	
Acceptable pH range	6-9	
Shaft seal type	2x Double lip	
Motor housing	Cast iron	
Volute case	Cast iron	
Impeller	Recessed vortex impeller	
Power cord	10' 18/3	3.05 m
	SJTW optional cord lengths are available	
Discharge, NPT	1-1/2"	
Min. sump diameter	10"	254 mm
Agency Approval	CSA, CUS	

FEATURES

- Performance where it counts with 60 GPM at 10' for 1/3HP or 76 GPM at 10' for 1/2HP
- Heavy-duty cast iron construction
- Upper and lower double lip seals deliver smoother operation
- Dual ball bearings
- Permanent split capacitor (PSC) motor promotes less energy consumption and longer life
- Multiple automatic switch options
- Raised inlet to reduce the maintenance time

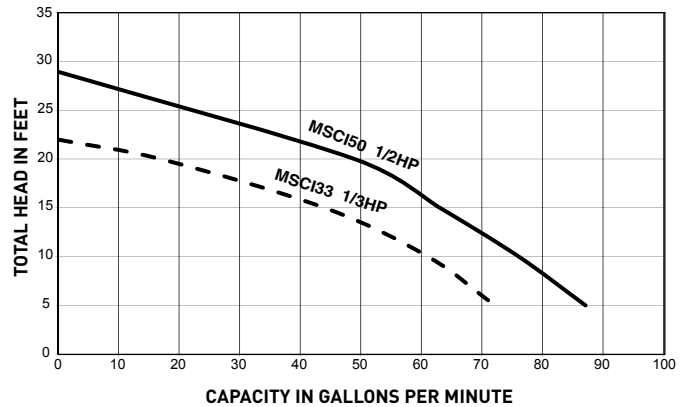

3 YEAR
WARRANTY

MODEL NUMBERS

MSCI33V10	MSCI50V20	MSCI50T50
MSCI33T10	MSCI50V50	MSCI50D10
MSCI33D10	MSCI50T10	MSCI50D20
MSCI50V10	MSCI50T20	MSCI50M20

MYERS® MSCI Series

Heavy Duty Cast Iron Submersible Sump Pumps

DIMENSIONS

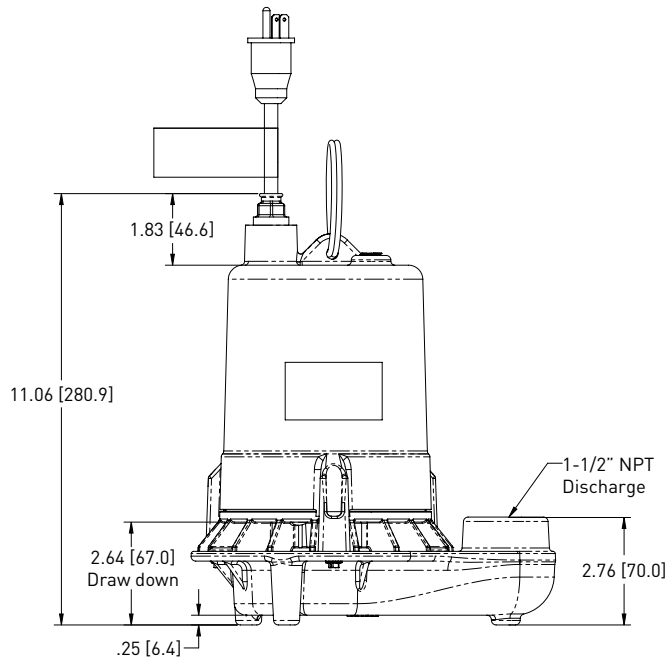

TETHERED AUTOMATIC

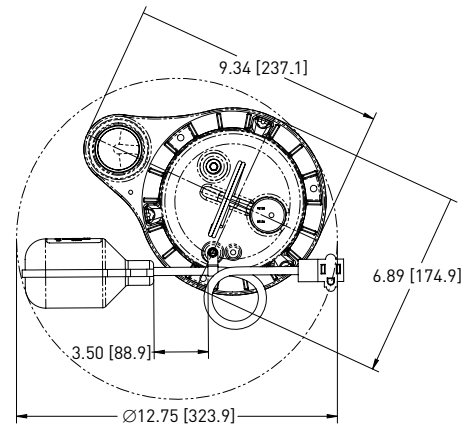

VERTICAL AUTOMATIC

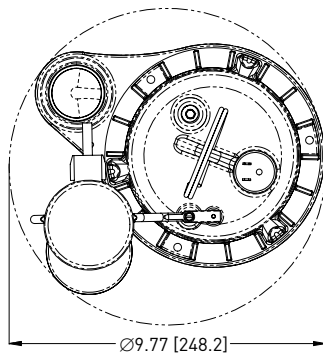

DIAPHRAGM AUTOMATIC

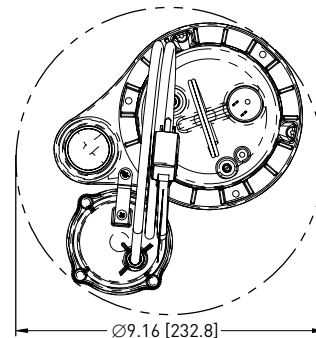

USA
293 WRIGHT STREET, DELAVAN, WI 53115 WWW.FEMYERS.COM
PH: 888-987-8677 ORDERS FAX: 800-426-9446

CANADA
490 PINEBUSH ROAD, UNIT 4, CAMBRIDGE, ONTARIO, N1T 0A5
PH: 800-363-7867 FAX # 888-606-5484

Because we are continuously improving our products and services, Pentair reserves the right to change specifications without prior notice.